

The RadiSys logo is a blue rectangular box with a white border, containing the text "RadiSys." in a white serif font. A thin white line extends from the right side of the box towards the title area.

RadiSys.

# **ASM386 Macro Assembler Operating Instructions**

RadiSys Corporation  
5445 NE Dawson Creek Drive  
Hillsboro, OR 97124  
(503) 615-1100  
FAX: (503) 615-1150  
[www.radisys.com](http://www.radisys.com)  
07-0578-01  
December 1999

EPC, iRMX, INtime, Inside Advantage, and RadiSys are registered trademarks of RadiSys Corporation. Spirit, DAI, DAQ, ASM, Brahma, and SAIB are trademarks of RadiSys Corporation.

Microsoft and MS-DOS are registered trademarks of Microsoft Corporation and Windows 95 is a trademark of Microsoft Corporation.

IBM and PC/AT are registered trademarks of International Business Machines Corporation.

Microsoft Windows and MS-DOS are registered trademarks of Microsoft Corporation.

Intel is a registered trademark of Intel Corporation.

All other trademarks, registered trademarks, service marks, and trade names are property of their respective owners.

December 1999

Copyright © 1999 by RadiSys Corporation

All rights reserved

# Quick Contents

---

## **Chapter 1. Introduction**

Introduces the manual, and the assembler and its related utilities.

## **Chapter 2. Using the Assembler**

An overview of the two methods by which the assembler's actions can be controlled in the host environment: the command-line syntax and the standard assembler controls that may be embedded in program sources.

## **Chapter 3. Assembler Control Reference**

A complete annotated list of the assembler-control switches.

## **Chapter 4. The Listing (Print File)**

A description of the assembly listing's contents.

## **Appendix A. Error Messages**

A descriptive list of error and warning messages issued by the assembler.

## **Appendix B. System Hardware and Software Requirements**

A description of the hardware and software requirements, and the procedure for making required modifications to the operating system.

## **Index**

## Notational Conventions

The notational conventions described below are used throughout this manual:

- italics*     Indicate a metasympol that must be replaced with an item that fulfills the rules for that symbol.
- system-id    Is a generic label placed on sample listings where an operating system-dependent name would actually be printed.
- V<sub>x.y</sub>        Is a generic label placed on sample listings where the version number of the product that produced the listing would actually be printed.
- [ ]            Brackets indicate optional arguments or parameters.
- |              The vertical bar separates options within brackets [ ] or braces { }.
- ...            Ellipses indicate that the preceding argument or parameter may be repeated.
- punctuation   Punctuation other than ellipses, braces, and brackets must be entered as shown. For example, the equal sign in the following statement must be entered as shown:  
`PAGEWIDTH=78`
- <ENTER>     Indicates a carriage return.
- file-spec*    Is the device name, the filename, and the file extension, if any.

## Related Publications

These manuals contain information on system utilities:

- *Intel386™ Family Utilities User's Guide*
- *Intel386™ Family System Builder User's Guide*

These additional Intel manuals may be of interest to users of the assembler and utilities in the DOS environment:

- *iC-386 Compiler User's Guide*
- *PL/M-386 Programmer's Guide*



# Contents

---

---

<b>1</b>	<b>Introduction</b>	
	About This Manual .....	1
	About This Chapter .....	1
	The Macro Assembler .....	1
	The System Utilities .....	2
	Inter-tool Consistency.....	4
	Inter-host Portability.....	4
<b>2</b>	<b>Using the Assembler</b>	
	Command Syntax .....	5
	Using Controls on the Command Line .....	6
	Sample Invocation Commands .....	7
	Interrupting the Assembler .....	8
	Controls .....	8
	Primary Controls .....	8
	General Controls.....	11
	Using Controls in the Source File.....	12
	Using Controls within Macros .....	14
	File Usage.....	16
	Source Program Restrictions .....	16
	Output Files .....	18
	Work Files .....	19
	Messages .....	20
	Automation of Program Invocation and Execution.....	21
	DOS Batch Files.....	21
	Passing Parameters to Batch Files.....	21
	Using Batch Commands .....	22
	DOS Command Files.....	22
	Redirection of Command Input to Batch Files .....	23

---

<b>3</b>	<b>Assembler Control Reference</b>	
	DATE .....	26
	DEBUG .....	27
	EJECT .....	28
	ERRORPRINT .....	29
	GEN/NOGEN/GENONLY .....	31
	INCLUDE .....	34
	LIST .....	35
	MACRO .....	36
	MOD386/MOD376/MOD486 .....	37
	N387/N287 .....	39
	OBJECT .....	40
	PAGELength .....	41
	PAGEWIDTH .....	42
	PAGING .....	43
	PRINT .....	44
	SAVE/RESTORE .....	45
	SYMBOLS .....	47
	TITLE .....	48
	TYPE .....	50
	USE32/USE16 .....	51
	WORKFILES .....	53
	XREF .....	54

---

<b>4</b>	<b>The Listing (Print File)</b>	
	The Default Print File .....	55
	Print File Headers .....	59
	Location Counter (LOC) .....	60
	Equated Symbols (EQU Directive) .....	60
	Floating-point Stack Elements (ST) .....	61
	COMM Variables and Labels .....	61
	Object Code (OBJ) .....	62
	Relocatable or External Code (R, E) .....	62
	Include Nesting Indicator (=) .....	62
	Line Numbers (LINE) .....	63
	Macro Expansion Indicator (+) .....	63
	Source Statements (SOURCE) .....	63
	The Symbol Table .....	64
	Symbol Table Fields .....	66
	Code macros (C MACRO) .....	66
	Public and External Symbols (PUBLIC, EXTRN) .....	66

Floating-point Stack Elements (F STACK).....	67
Instruction .....	67
Keyword.....	67
Labels (L NEAR, L FAR).....	67
Numbers (NUMBER) .....	67
Procedures (P NEAR, P FAR) .....	67
Records and Record Fields (RECORD, R FIELD) .....	67
Registers (REG) .....	68
Segments (SEGMENT).....	68
Stack Segments (STACK).....	68
Structures and Structure Fields (STRUC, S FIELD).....	68
Undefined Symbols (-----).....	68
Variables (V BIT . . . V n).....	69

---

## **A Error Messages**

Fatal Errors.....	65
Invocation Control Errors.....	65
I/O Errors .....	66
Internal Errors .....	66
Nonfatal Errors and Warnings .....	67
Syntax Errors.....	67
Warnings .....	68
Macro Errors .....	69
Control Errors.....	69
Source File Error and Warning Messages.....	70

---

## **B System Hardware and Software Requirements**

Hardware and Software Requirements .....	81
Modifying the System Configuration .....	82

---

<b>Index</b>	<b>83</b>
--------------	-----------

---

**Tables**

Table 2-1. Assembler Primary Controls .....	10
Table 2-2. Assembler General Controls.....	11
Table 2-3. Assembler Program Restrictions .....	17

---

**Figures**

Figure 1-1. Processor Translation System .....	2
Figure 2-1. Macro Assembler Logical File.....	19
Figure 3-1. Sample Listing for GEN/NOGEN/GENONLY .....	33
Figure 3-2. Sample Listing for SAVE/RESTORE.....	46
Figure 4-1. Sample Print File Page.....	56
Figure 4-1. Sample Print File Page (continued).....	57
Figure 4-1. Sample Print File Page (continued).....	58
Figure 4-2. Sample Symbol Table .....	65

## About This Manual

This manual describes how to use the Macro Assembler on DOS and iRMX<sup>®</sup> host systems. The information contained in this manual supplements the manual set for the ASM386 assembler and its associated utilities.

ASM386 supports the Intel386<sup>™</sup>, Intel486<sup>™</sup>, and Pentium<sup>®</sup> microprocessors as well as floating-point coprocessors. Throughout this manual, the word "processor" refers to any of the above microprocessors and the words "floating-point coprocessor" refer to any of the related math coprocessors, as well as the Intel486 and Pentium processor's built-in floating-point functions.

Bound with this manual is the *ASM386 Assembly Language Reference*. This is the basic reference for the assembler language, and contains information that is independent of the host operating system (e.g., the complete instruction set).

## About This Chapter

This chapter introduces the assembler and its related utilities. The assembler generates code for target systems based on the Intel386, Intel486, and Pentium microprocessors. The utilities are tools that prepare loadable and executable modules for execution on the target system. Figure 1-1 illustrates the development process using Intel translators and utilities.

## The Macro Assembler

The assembly language translator has the following characteristics:

- Translates files written in assembly language into linkable object modules
- Produces object modules (OMF-386) that can be assembled separately and linked to programs written in ASM286 assembly language

The assembler supports the full processor and floating-point coprocessor instruction sets. The instruction set and assembler mnemonics are compatible with ASM286, the assembly language for the 286 processor.

Program modules may be debugged with Intel debuggers or in-circuit emulators such as the ICE™ -386 system.

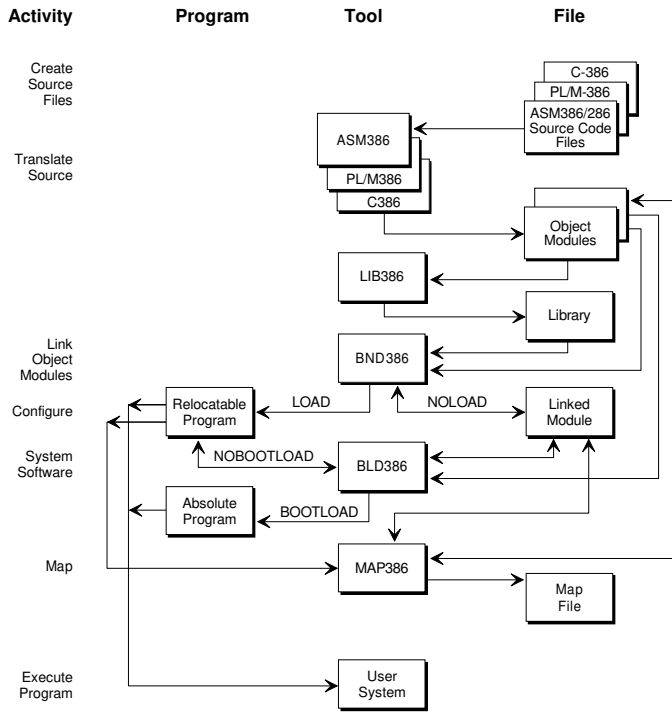

W-3418

**Figure 1-1. Processor Translation System**

## The System Utilities

The system utilities are a set of software development tools that:

- Combine modules produced by the assembler, by compilers generating OMF-386 code, and by the Librarian (LIB386) into executable programs
- Support incremental linking
- Assign addresses to code in the processor's 4-gigabyte physical address space
- Generate print files containing system cross-reference listings, error and warning messages

Object files created by the assembler must be processed by the binder (BND386) and/or the system builder (BLD386) before they can be loaded and executed. BND386 creates an executable, relocatable program from separately translated modules. The librarian (LIB386) organizes linkable modules into a library. The mapper (MAP386) produces a listing describing the features of linkable or executable object files. All three are considered linking tools.

BLD386 is not a linking tool. It configures system software for the processor operating in protected mode and using virtual addressing. BLD386 may be used to perform the following tasks:

- Creating and modifying descriptor tables, segment and system descriptors (including gates), and task state segments
- Creating page tables and directories for use in paged memory systems
- Assigning physical addresses to segments and descriptor tables
- Configuring system interface files for use in developing application programs

## Inter-tool Consistency

Whether or not you have previous experience using Intel software development tools, such as language translators like the assembler and related system utility programs, you will find broad consistency among the tools described in this manual. Most Intel language processors, for example, have similar invocation syntax, message formats, and features.

The various Intel assemblers and compilers for any particular target generate the same object module format. Therefore you can use the appropriate mix of assembly and higher-level language modules to develop your application system.

## Inter-host Portability

The user interfaces of the various tools within a family are also consistent across host environments. This means that if you can operate an assembler or a compiler on a DOS system, for example, you already know most of what is required to operate the iRMX-hosted version of that tool.



# Using the Assembler 2

---

This chapter explains how to anticipate and control the input and output of the assembler. It contains full textual explanations for new users and tabular summaries for those already familiar with the assembler.

## Command Syntax

Assembler invocation syntax is as follows:

```
ASM386 file-spec [control...] %macro-string
```

Where:

*ASM386* is the command.

*file-spec* represents the name and extension (optional) of the source file to be processed.

*control* represents a switch that controls the process, such as `DEBUG`, `NOOBJECT`, `PRINT` and others. You may abbreviate them as shown in Chapter 3.

*%macro-string* directs the assembler to include the specified macro. The macro string is a legal statement of up to 212 characters in the assembler macro processing language. This macro is processed before reading the source files. The macro metacharacter `%` must precede the macro-string, as follows:

```
ASM386 MYPROG "%set (a,1) "
```

Only one macro may be specified in each command.

See also: Using Controls with Macros, in this chapter

## Using Controls on the Command Line

A set of assembler-control switches govern the format, processing, and content of both the input source and the output files. These switches are called controls and they also may be embedded in source files and included files. Controls are widely used among Intel language translators.

Most controls allow you to regulate the form and/or content of assembler output files. For example, the `USE16` control directs the assembler to generate 16-bit addresses and offsets for the current module. Some controls are in pairs that specify on/off conditions. The off condition is indicated by the word `NO` at the beginning of the name. For example, use `PRINT` to create a source listing or `NOPRINT` to suppress the listing.

Not all controls are used in commands. The `EJECT` and `SAVE/RESTORE` controls cannot be specified on the command line.

Control use is optional. If you use no controls in your invocation commands, the assembler and utilities function according to default settings described in Chapter 3 and in the other supplied publications.

For the following command example, a source module named `PROG1.SRC` is assembled using default control settings. The assembler writes the object and listing file to predetermined file specifications, using the source file name with the extensions `OBJ` and `LST`.

```
ASM386 PROG1.SRC
```

The object file is `PROG1.OBJ` and the listing is named `PROG1.LST`; both are placed in the current working directory.

Some controls take one or more parameters. Use parentheses to indicate the parameter delimiters. Separate multiple parameters by commas and enclose the entire group in parentheses.

Enclose a control's parameter in quotation characters if it contains any of the following characters:

```
, ( ) = # ! ' ' ~ + - & | < >
```

For example:

```
ASM386 MYPROG.SRC TITLE("Joe's Program")
```

If the control's parameter contains quotation characters, enclose it in apostrophes. This allows the assembler to distinguish parameter strings from strings to be parsed. For this reason, a macro or title statement in the command must also be enclosed in quotation characters.

See also:    Using Controls in the Source File, in this chapter  
              assembler controls, Chapter 3  
              listing file, Chapter 4

## Sample Invocation Commands

The following invocation examples show general guidelines for control usage.

1. Assume that a source file named `MYPROG.SRC` is in the working directory. In its simplest form, the command line is:

```
ASM386 MYPROG.SRC
```

The assembler uses the default values of the control settings to write the object module to the file `MYPROG.OBJ` and the listing to `MYPROG.LST`.

2. Assume that the source file is again named `MYPROG.SRC` and the command line is:

```
ASM386 MYPROG.SRC PRINT(PROG1.LST) TITLE(PLANS)  
PAGEWIDTH(78)
```

The results are:

- The object file is named `MYPROG.OBJ` (the default) and the listing file is named `PROG1.LST`, as specified by the `PRINT` control.
- `TITLE` places `PLANS` in the header of each page in the listing.
- The pages are 78 characters wide, as specified, and 60 lines long, the default value for `PAGELength`.

3. Assume that the source file is named `MYPROG.SRC` and the command is:

```
ASM386 MYPROG.SRC XREF DEBUG TYPE
```

This invocation results in the following:

- By default, the object file is named `MYPROG.OBJ` and the listing is named `MYPROG.LST`.
- The object file contains local symbol information (`DEBUG`) and type information (`TYPE`) for variables and labels. This information is useful for symbolic debugging.
- The listing has the default format: width of 120 characters and length of 60 characters.
- The cross-referenced symbol table listing is included at the end of the listing (`XREF`).

## Interrupting the Assembler

Use `<Ctrl-Break>` to interrupt or abort the assembler. `<Ctrl-C>` does not work as the interrupt character like `<Ctrl-Break>`.

## Controls

The assembler recognizes two kinds of controls, primary and general, which affect the assembly of a program as explained in Primary Controls or General Controls. Assembler control names can be abbreviated as shown in Table 2-1 and Table 2-2.

See also: Using Controls in the Source File, in this chapter

## Primary Controls

Primary controls set conditions that apply throughout the entire assembly of a module. For example, the `DEBUG` primary control causes all local symbol information from the source module to be included in the object file. Table 2-1 lists the primary controls. The actions of the `NO` controls are the opposite of the descriptions of their companion control.

Place primary controls in the first line in the source file. Such lines are called primary control lines. Blank lines and comment lines are considered noncontrol lines.

If you specify the same primary control in a source file as you've entered on the command line, the command-line control's specification takes effect. If you specify a primary control in multiple primary control lines, the condition specified last takes effect.

For example, assume that the source file contains the following primary control lines:

```
$DEBUG NOPAGING
$PRINT (MYLIST)
$PAGING
```

Assume the invocation line is as follows:

```
ASM386 MYFILE.ASM PRINT NODEBUG
```

The assembly proceeds as follows:

- The source listing is sent to a file named `MYFILE.LST`. The default file name is the source module name with the `LST` extension. `PRINT` in a command overrides `PRINT` in the control line, so that the listing appears as `MYFILE.LST` instead of `MYLIST`.
- No debug information is included in the object file because `NODEBUG` in the command line has precedence over `DEBUG` in the control line.
- The listing is paged because `PAGING` in the third control line cancels out `NOPAGING` in the first control line.

**Table 2-1. Assembler Primary Controls**

<b>Controls</b>	<b>Abbr.*</b>	<b>Default</b>	<b>Action by Assembler</b>
DATE ( <i>date</i> )	DA	System time	No effect; provided for compatibility with ASM86.
DEBUG	DB	NODB	Places local symbol information in the object file.
NODEBUG	NODB		
ERRORPRINT[( <i>file-spec</i> )]	EP	NOEP	Creates a file containing error or warning messages.
NOERRORPRINT	NOEP		
MACRO( <i>parameter</i> )	MR	MR	Specifies that macros are processed during assembly.
NOMACRO	NOM		
	R		
MOD386	--	MOD386	Verifies that the input file meets Intel386, 376, or Intel486 requirements, respectively.
MOD376			
MOD486			
N387	--	N387	Generates code for Intel387™ or Intel287™ coprocessors.
N287			
OBJECT[( <i>file-spec</i> )]	OJ	OJ	Creates an object module.
NOOBJECT	NOOJ		
PAGELength( <i>length</i> )	PL	PL(60)	Specifies lines/page in the listing. Specifies characters/line in the listing.
PAGEWIDTH( <i>width</i> )	PW	PW(120)	
PAGING	PI	PI	Formats the listing in pages.
NOPAGING	NOPI		
PRINT[( <i>file-spec</i> )]	PR	PR(source-file.LST)	Creates a source listing to be printed or displayed.
NOPRINT	NOPR		
SYMBOLS	SB	NOSB	
NOSYMBOLS	NOSB		Places a symbol table in the listing.
TYPE	TY	NOTY	Places type information for public symbols in the object file.
NOTYPE	NOTY		
USE32	U32	U32	Generates 16- or 32-bit addresses and offsets for the current module.
USE16	U16		
WORKFILES( <i>dir</i> [,...])	WF	WF(:WORK:)	Names directory to contain intermediate files.
XREF	XR	NOXR	Places a cross-referenced symbol table in the listing.
NOXREF	NOXR		

\* Abbreviations may be used only in control files or in source files, not in invocation commands.

## General Controls

A general control causes an immediate action and takes effect with the next source line. For example, `EJECT` places the next line of the source file listing on a new page, and `LIST` specifies that the source listing resumes with the next source line read. Table 2-2 lists the general controls.

You can specify general controls many times within a source file to set conditions during assembly. For example, you can selectively include portions of the source code in the listing by starting it with `LIST` and stopping it with `NOLIST` as desired. As another example, you can specify `INCLUDE` at selected locations in order to insert the contents of files.

The command-line equivalents of general controls take effect before the first source line is read, but have no precedence over general controls in the source file. The last setting specified is in effect.

**Table 2-2. Assembler General Controls**

<b>Control</b>	<b>Abbr.*</b>	<b>Default</b>	<b>Assembler Function</b>
EJECT	EJ	---	Starts a new page in the listing (print file).
GEN	GE	GENONLY	Controls the listing of macros in the listing (print file).
GENONLY	GO		
NOGEN	NOGE		
INCLUDE	IC	---	Inserts the specified file in the source input.
LIST	LI	LIST	Turns the source listing on.
NOLIST	NOLI		Turns the source listing off.
SAVE	SA	---	Saves settings of affected controls on the stack.
RESTORE	RS	---	Restores settings of affected controls from the stack.
TITLE	TT		Determines the page header for the listing (print file).

\* Abbreviations may be used only in control files or in source files, not in invocation commands.

## Using Controls in the Source File

You can place assembler controls directly in the source file, giving you selective control over sections of the program. For example, you can suppress certain sections of the source listing with the `NOLIST` control. Placing controls within a source module can also save time because you do not need to retype them each time you invoke the assembler for a particular module.

To temporarily change a condition specified in a control line, you need not edit the source. You can simply specify the new condition using a primary control on the command line, and it takes effect because a primary control in a command has precedence over the same primary control within the source file. This technique cannot be used with general controls.

Source file lines containing controls are called control lines. They begin with the dollar sign (\$) and contain any number of controls and their parameters, up to the host operating system's limit for characters in a source line. Control lines do not contain other types of assembly language statements. If you do not specify a control, its default value is in effect. Table 2-1 and Table 2-2 give the default value of each control.

See also: Control defaults, Chapter 3

Control lines are recognized and processed immediately when they appear in the source file except when included in macro definitions. The guidelines for specifying controls given earlier in this chapter apply to control lines with the following additions and exceptions:

- Begin the control line with a dollar sign (\$) in column one. The first control must follow the dollar sign immediately, as follows:  

```
$PAGEWIDTH(132)
```
- Terminate control lines with a carriage return (CR).
- Separate each control with a space.
- Primary controls must be placed before any general controls or source code in a source file.
- Specify multiple controls on a single line but, unlike other assembly language statements, do not continue control lines.
- Control lines may end with comments. A comment begins with a semicolon (;) and continues for the remainder of the line. For example:

```
$TITLE (Section2) EJECT; next section
```

- A control with a parameter uses parentheses to indicate the parameter. Multiple parameters are separated by commas and the entire group is enclosed in parentheses.
- No blanks are required between controls and parameters because the parentheses around the parameters act as separators. For example, the following two lines are equivalent:

```
$PRINT (MYPROG.PRT) PAGEWIDTH(78) NOPAGING
$PRINT(MYPROG.PRT)PAGEWIDTH(78)NOPAGING
```

However, you must enter blanks between controls where no parentheses act as separators. For example:

```
$XREF NOPAGING
```

- Enclose names of included, listing, errorprint, and object files specified within either single or double quotation marks if they contain spaces or any of the following characters:

```
' , ( ) = # ! $ % \ ~ + - & | < > [ ]
```

For example:

```
$INCLUDE ("Clude(s).INC")
```

See also:     Specifying controls, in this chapter  
               Using Controls within Macros, in this chapter

In the following example, controls specified at invocation can override controls within the source file.

## Example

Assume that the source file MYPROG.ASM contains the following control line:

```
$SYMBOLS PAGEWIDTH(60)
```

The command is:

```
ASM386 MYPROG.SRC NOPRINT
```

In this case, the control lines do not produce the usual results. Normally, SYMBOLS adds a symbol table to the listing and PAGEWIDTH sets the width of lines in the listing. Placing NOPRINT on the command line causes SYMBOLS and PAGEWIDTH to be ignored because no listing is generated.

The following section explains some of the considerations for specifying controls within macro definitions.

## Using Controls within Macros

The assembler usually recognizes and processes control lines as soon as they appear in a source file. However, the assembler can conditionally generate control lines if you place them within macro definitions or the body of a statement containing the `IF`, `WHILE`, or `REPEAT` predefined macros. The assembler then delays recognition and execution of the control line until the macro is called or the `IF`, `WHILE`, or `REPEAT` is expanded.

The assembler macro processor has two scanning modes: normal and literal. In normal scanning mode, the assembler recognizes and expands all macros. In literal scanning mode, the assembler treats nested macro calls as ordinary text strings.

Literal mode is selected by placing an asterisk (\*) after the macro metacharacter, which is % by default, as in the following example:

```
%*DEFINE (AB) (%EVAL (%TOM) )
```

Literal mode is also in effect by default for `THEN` and `ELSE` clauses, because these clauses are conditional in nature. The examples at the end of this section also illustrate these concepts.

See also: Macro processing language and scanning modes, *ASM386 Assembly Language Reference*

The scanning mode in effect when the control line indicator `§` is scanned determines how the assembler processes a control line. If the `§` is encountered when the macro processor is in normal mode, the assembler treats the rest of the line as a control line and processes it immediately. If the `§` is scanned in literal mode, the `§` and the rest of the line are treated as ordinary text.

The following criteria apply to the way control lines are scanned:

- The line feed (LF) at the end of a control line must be at the same nesting level as the opening `§`. Parentheses must be used in pairs.
- A control line in a macro adds one level to the macro nesting.
- If a macro error occurs inside a control line, the traceback of macro nesting information includes an item for the control, as a "call" to the `§`.

The following examples illustrate the use of controls in macros.

## Examples

1. This example shows a macro whose definition is included from another file:

```
%DEFINE (MAC) (  
$INCLUDE (FILE1)  
)
```

Because `DEFINE` is called normally, with `%` instead of `%*`, the body of the definition is scanned in normal mode. Consequently, the `INCLUDE` control line is recognized immediately and `MAC` is defined as the contents of the `INCLUDE` file. In other words, the contents of `FILE1` are stored as the value of `MAC`.

2. The following example shows the definition of a macro that includes a file when it is called:

```
%*DEFINE (MAC) (  
$INCLUDE (FILE2)  
)
```

`MAC` is scanned in literal mode because of the `%*` notation preceding the `DEFINE` function. Consequently, the `INCLUDE` control line itself is the definition of `MAC`, not the contents of `FILE2`, as would have been the case in normal mode (refer to the previous example). When `MAC` is called, `FILE2` is read.

3. The following example illustrates how to conditionally include one of two files using `IF..THEN..ELSE` clauses:

```
%IF(condition) THEN (  
$INCLUDE (FILE3)  
)ELSE (  
$INCLUDE (FILE4)  
)FI
```

This example demonstrates how scanning modes are combined. Even though `IF` is not preceded by `%*`, both the `THEN` and `ELSE` clauses are scanned in literal mode because they are conditional statements. However, because `%*IF` was not used, the selected `THEN` or `ELSE` clause is scanned in normal mode and `FILE3` or `FILE4` is immediately included. In this situation, `%*IF` would not be useful. `IF` must always be closed by an `FI` after the last parenthesis.

4. The following example shows the definition of a macro that generates either the LIST or NOLIST control:

```
%*DEFINE (PRINT (X)) (
  $%X% () LIST
)
```

The macro call

```
%PRINT ()
```

would produce the control line

```
$LIST
```

while the call

```
%PRINT (NO)
```

would produce the control line

```
$NOLIST
```

## File Usage

File sharing conflicts may occur when using an Intel translator or Relocation and Linkage (R&L) tool in a DOS network environment. Before invoking an Intel translator or R & L tool (with network support from DOS), invoke the DOS V3.0 or later SHARE command. It is recommended that you invoke the SHARE command in your AUTOEXEC.BAT file.

After successful assembly, the assembler can produce an object file, a listing, and an errorprint file. Each of these files is optional; certain assembler controls allow you to specify them. Other assembler controls allow you to regulate their contents.

## Source Program Restrictions

The assembler places quantitative restrictions on certain items within source programs, such as the number of characters in a source line. Most of these restrictions are listed in Table 2-3.

If your program exceeds a limit, the assembler returns an error. Most quantities in Table 2-3 are upper limits, but some items show both upper and lower limits. The table also points out some items for which there are no limits.

**Table 2-3. Assembler Program Restrictions**

<b>Item</b>	<b>Limit</b>
Source lines/programs	No limit
Characters per line	255 including CR/LF and nonprinting characters
Characters per identifier	31 unique, up to 255 total
Symbols per module	2700 standard 3200 with Intel Above™ Board
Continued lines per statement	No limit
Characters per string	255 including enclosing quotation marks
Segment size	64K bytes (USE16 segments) 4 gigabytes (USE32 segments)
Number of bytes	Size cannot exceed 1K that can be duplicated
Procedure nesting	20 levels per segment
Items in each PUBLIC, EXTRN, and PURGE directive	Limited by the number of symbols
Parameters in all macro calls	255
Combined total of macro calls, active macro expansions, and nested INCLUDEs	64 levels
Items per storage initialization list	No limit
Fields per record	32
Record size	32 bits
Structure size	64K - 1 bytes (USE16) 4 gigabytes -1 (USE32)
Fields per structure	255
Parameters per codemacro definition	15
Bytes generated by each codemacro	255

## Output Files

There are three possible output files: the object file, the listing or print file, and the errorprint file.

The object file contains assembled processor machine code, data initializations, symbol and type information, and the information necessary for combining the object module with other modules. After processing by the processor system utilities, the object file for a source module becomes part of an executable program. The assembler produces the object file by default unless you specify the `NOOBJECT` control.

The object file can optionally contain symbol and type information that is useful for symbolic debugging and inter-module type checking. The information is included if you specify the assembler's `DEBUG` and `TYPE` controls.

The listing file (or print file) contains the source lines, expanded macro source code, object code, and any source file error or warning messages produced by the assembler. Several assembler controls determine the format and content of the file. For example, the `SYMBOLS` control directs the assembler to include an optional list of symbols defined in the source program, called the symbol table. The assembler produces the listing by default unless you specify the `NOPRINT` control. 4.

The errorprint file is a summary of the errors and warnings encountered during assembly. It contains the source lines in which the errors occurred and the error messages. By default, this summary goes to the console output with the logical name `:CO:.` If the `ERRORPRINT` file has not been assigned to another file, it is directed to the screen. The assembler does not produce an errorprint file unless you specify the `ERRORPRINT` control. Figure 2-1 shows the assembler's logical files.

See also: `NOOBJECT`, `DEBUG`, `TYPE`, `SYMBOLS`, `NOPRINT`, and `ERRORPRINT` controls, Chapter 3  
listing file, Chapter 4

The DOS manual indicates that the maximum number of characters in a pathname is 63, but in practice various products seem to restrict pathnames to less than 63 characters. To ensure compatibility with all products, make sure that all output pathnames do not exceed 43 characters. A fatal error is generated if your output pathname is too long, and the translator or R & L tool aborts.

In iRMX systems, you can use the **attachfile** command to assign a logical name to a long pathname. For example:

```
af /directory/subdirectory/subdirectory as f
```

You can then use the logical name as follows:

```
asm386 :f:file.asm
```

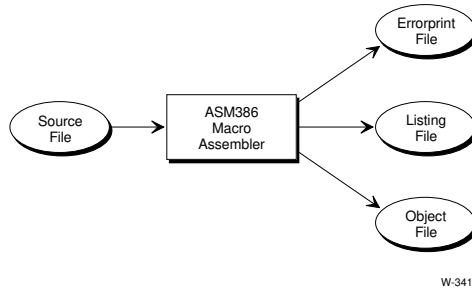

**Figure 2-1. Macro Assembler Logical File**

## Work Files

The assembler creates temporary work files while processing the source and deletes them when the assembly is completed. These files are allocated to the `:WORK:` logical device and they do not conflict with any other files.

Under DOS, you may use the `SET` command to select the drive on which work files are placed. For example, this command places them in the root directory on drive `D:`:

```
C>SET :work:=D:\
```

This capability is useful when a virtual disk in memory has been created with the DOS `VDISK.SYS` device driver.

Confusion may occur on user-defined logical names. The default assignments for `:F0:` through `:F9:` and `:WORK:` are not in the user manuals. If these logical devices are not defined with the `SET` command, the default assignments for `:F0:` through `:F9:` are to devices `A` through `J`. The default assignment for `:WORK:` is the current default disk. Use the `SET` command to assign the desired logical devices.

Under `iRMX`, `:work:` is defined by the operating system as the `:SD:work` directory. The user can establish other logical names (such as `:F0:`, `:F1:`, etc) using the **attachfile** command.

Files consisting of an 8-digit hexadecimal number with no extension may be left in the current `:WORK:` directory after you type CTRL-BREAK to abort an Intel translator or R & L tool or a user program converted to DOS with UDI2DOS.EXE. These are temporary files created by these programs to store intermediate data. They are normally deleted at the end of a program's normal execution. Delete or ignore the files. No important information is contained in them.

## Messages

After invocation, the macro processor within the assembler scans the source file for macros and processes them. In the next phase, referred to as pass 1, the assembler constructs the symbol table. Lastly, during pass 2, the assembler completes the actual translation. Most assembler errors are detected during pass 1. If the assembler detects an error in pass 2, the error message contains "(PASS 2)".

Immediately after invocation, the assembler displays the following sign-on message:

```
system-id Intel386 MACRO ASSEMBLER Vx.y  
Copyright year(s) Intel Corporation
```

Where:

*system-id* is the string returned by the operating system.

*x.y* is the version number.

*year(s)* lists the copyright year(s).

If the assembler did not detect any fatal errors during assembly, it displays the following sign-off message:

```
ASSEMBLY COMPLETE, n WARNINGS m ERRORS
```

where *n* and *m* represent the number of warning and nonfatal error conditions, respectively, that occurred during processing.

When the assembler detects certain severe errors, it stops processing the source file and exits to the operating system without producing an object or listing. It produces an error message ending with "ASM386 TERMINATED".

See also: Assembler error messages, Appendix A

# Automation of Program Invocation and Execution

DOS allows you to invoke and execute multiple programs either by using batch files or command files. The following sections provide examples that demonstrate how to use these files with the assembler and the binder, BND386.

See also: For details on BND386 and the other utilities, *Intel386 Family Utilities User's Guide*.

## DOS Batch Files

A batch file contains one or more invocation commands or DOS batch commands that DOS executes one at a time. All batch files must have the extension `BAT`. This section explains how to create batch files that invoke several programs at once and that can operate on different sets of input files.

See also: DOS batch files, in your DOS manual



### Note

DOS batch files cannot be nested. If a batch file references another batch file, control passes directly to the other batch file, but control does not return to the referring batch file.

## Passing Parameters to Batch Files

It is possible to pass parameters to a DOS batch file when the file executes. The batch file can do similar work on a different program or set of data each time the batch file is executed. The following example illustrates this use of a batch file.

In the following example, the batch file `ASM.BAT` contains the command sequence that invokes the assembler and BND386 for two modules. Any assembler source file with the extension `ASM` can be passed as a parameter to `ASM.BAT`. Each percent sign and its accompanying digit in the batch file is replaced with the parameters specified on the command line that invokes the batch file. For instance:

```
ASM386 %1.ASM
ASM386 %2.ASM
BND386 %1.OBJ, %2.OBJ
```

Invoke the batch file by typing the name of the batch file without the `BAT` extension, followed by the names of the source files to be translated, without the `ASM` source file extension, as follows:

```
C>ASM PROG1 PROG2
```

ASM.BAT invokes the assembler to assemble PROG1.ASM and PROG2.ASM and passes the resulting files PROG1.OBJ and PROG2.OBJ to BND386. BND386 then links the two files and, by default, produces one executable file named PROG1.

## Using Batch Commands

In addition to program invocation commands, batch files can contain DOS batch commands (or subcommands) such as FOR, IF, and GOTO. Such commands enable you to write a batch file that executes programs conditionally or repeatedly.

See also: Batch file commands, in your DOS manual

## DOS Command Files

Under DOS version 2.0 or later, it is possible to invoke the DOS command-line interpreter program, COMMAND.COM, with input that is redirected from a file (called a command file). This file can contain DOS commands and invocation commands for programs such as the assembler. A command file must contain the DOS EXIT command.

For example, assume you created a command file named MAKEPROG.CMD that contained the following information:

```
ASM386 MAIN.ASM
ASM386 IO.ASM
PLM386 UTIL.PLM
BND386 MAIN.OBJ, IO.OBJ, UTIL.OBJ
EXIT
```

You can redirect the commands in this file to COMMAND.COM by entering the following:

```
C>COMMAND <MAKEPROG.CMD
```

COMMAND.COM then invokes all commands listed in the file MAKEPROG.CMD.

The following considerations apply when invoking COMMAND.COM with input that is redirected from a command file:

- Command files can only contain fixed sequences of commands; you cannot pass parameters to COMMAND.COM.
- Command files cannot support conditional DOS batch commands such as IF and GOTO; commands are always executed sequentially.

- Command files can be nested by reinvoking `COMMAND.COM` from the primary command file with input redirected from a secondary command file. The secondary command file must contain an `EXIT` command as its final line. When the `EXIT` command is executed, control returns to the point in the primary file immediately following the point from which the secondary file was invoked.
- Command files, unlike DOS batch files, can contain continuation lines. For example, the following is a valid command file:

```
BND386 FILE1.OBJ,FILE2.OBJ,FILE3.OBJ, &
NOTYPE OJ (PROG1.OBJ)
EXIT
```

The ampersand is the line continuation character.

- Output from a command file may be redirected to another file in order to obtain a complete log of all console output created during the command file's execution, including the invocation line for each program executed in the command file. For example, the following command invokes the command file `MAKEPROG.COM` and creates a log file named `MAKEPROG.LOG`.

```
C>COMMAND <MAKEPROG.COM>MAKEPROG.LOG
```

## Redirection of Command Input to Batch Files

DOS batch files can contain multiple invocation lines, but each invocation line must fit on a single line. No line continuation characters (such as the ampersand) are allowed within batch files. To process continuation lines in batch files, you must redirect the input from a file that contains continuation lines to a batch file. The following example shows how to do this.

In this example, two files are created: the batch file `LINKBIG.BAT` and `LINKBIG.CON`, which contains continuation lines. `LINKBIG.CON` is redirected to `LINKBIG.BAT` upon execution.

`LINKBIG.BAT` contains the line:

```
BND386 MODULE1.OBJ,MODULE2.OBJ <LINKBIG.CON
```

`LINKBIG.CON` contains the continuation line:

```
MODULE3.OBJ,MODULE4.OBJ FASTLOAD NODEBUG NOEP & NOPR NOTYPE
```

When `LINKBIG.BAT` is executed, `BND386` is invoked, linking the four modules with the specified set of `BND386` controls.

The sample file, `LINKBIG.CON` could also be redirected to a batch file that contains multiple invocation lines, as long as this batch file contains no continuation lines. For example, the batch file that follows, `GENBIG.BAT`, contains several invocation lines:

```
ASM386 MODULE1.ASM
ASM386 MODULE2.ASM
ASM386 MODULE3.ASM
ASM386 MODULE4.ASM
BND386 MODULE1.OBJ,MODULE2.OBJ, & <LINKBIG.CON
```

At execution, all of the modules in `GENBIG.BAT` are assembled and then linked with the set of `BND386` controls specified in `LINKBIG.CON`.



# Assembler Control Reference

---

# 3

This chapter contains a detailed description of each assembler control, listed in alphabetical order. Each description contains the syntax, default value, type (primary or general), abbreviation, and an explanation of its usage. Syntax descriptions include a command-line form and a source-file form. In many cases, the same syntax is used for both forms.

Certain controls override others, causing them to be ignored by the assembler. For example, if the `NOPRINT` control is in effect, the assembler ignores a `SYMBOLS` control because it cannot create a symbol table if it does not create a print file. Each control description explains the overrides for the control, if any.

See also:    Command-line syntax, Chapter 2

## DATE

### Syntax

<b>Command Line</b>	DATE ( <i>date</i> )
<b>Source File</b>	DATE ( <i>date</i> )
<b>Abbreviation</b>	DA

### Default

System time

### Type

Primary

### Discussion

The `DATE` control is supplied for compatibility with ASM86. The control is processed but the date parameter is ignored. The date that appears in the print file is obtained through a call to the operating system.

---

# DEBUG

## Syntax

<b>Command Line</b>	DEBUG NODEBUG
<b>Source File</b>	DEBUG NODEBUG
<b>Abbreviation</b>	DB NODB

## Default

NODEBUG

## Type

Primary

## Discussion

DEBUG directs the assembler to include local symbol information for variables and labels in the object file for use in symbolic debugging. In addition, with the DEBUG control in effect, the assembler includes LINES and SRCLINES information for debugger support. NODEBUG directs the assembler to omit debugging information from the object file.

Depending on the contents of your source file, DEBUG can significantly increase the size of the object file produced.

The NOOBJECT control overrides the DEBUG and NODEBUG controls.

In ASM386 V4.0, the DEBUG primary control generates debug information in the object module necessary to support source-level display by debuggers.

If the source level debug support is not desired, the size of the loadable object file may be reduced by specifying the default NODEBUG control.

If symbolic debug information is desired without source level debug support, the SRCLINES and LINES debug information may be purged from a loadable object module using MAP386.

See also: MAP386 and the OBJECTCONTROLS option, *Intel386 Family Utilities User's Guide*

## EJECT

### Syntax

<b>Source File</b>	EJECT
<b>Abbreviation</b>	EJ

### Type

General

### Discussion

EJECT directs the assembler to create a new page in the source listing, beginning with the next source line. Additional EJECT controls on a single control line are ignored. The EJECT control is not allowed on the command line.

The following is a list of interactions between EJECT and other assembler controls:

- If EJECT appears in a line suppressed by an earlier NOLIST control, a new page begins when the listing is started again by the appearance of LIST.
- If the NOPRINT control is in effect, EJECT is ignored.
- The NOPAGING control overrides any EJECT controls.

# ERRORPRINT

## Syntax

<b>Command Line</b>	ERRORPRINT [ ( <i>file-spec</i> ) ] NOERRORPRINT
<b>Source File</b>	ERRORPRINT [ ( <i>file-spec</i> ) ] NOERRORPRINT
<b>Abbreviation</b>	EP NOEP

## Default

NOERRORPRINT

## Type

Primary

## Discussion

ERRORPRINT directs the assembler to create a file containing only error messages and their corresponding source lines or to print such a summary on the terminal screen. Each line and error message summary has the same form as in the full listing. For example:

```

system-id Intel386
MACRO ASSEMBLER x.y ASSEMBLY OF MODULE MYPROG
OBJECT MODULE PLACED IN MYPROG.OBJ
ASSEMBLER INVOKED BY: ASM386 ERRORPRINT MYPROG.ERR MYPROG.ASM
LOC   OBJ                               LINE   SOURCE
-----
                                31   DATA   ENDS
*** WARNING #354 IN 31, SEGMENT CONTENTS DO NOT AGREE WITH ACCESS-TYPE

```

If you do not supply a file specification, the assembler prints an error summary similar to the above on the terminal screen, followed by the standard assembler sign-off message.

See also: Error message formats, Appendix A

NOERRORPRINT directs the assembler not to create the error summary file.

ERRORPRINT and NOPRINT can be specified for the same assembly because the assembler can generate an errorprint file without generating a print file.

## ERRORPRINT

---

Place quotation marks around errorprint file names that are specified in the source file if they contain spaces or any of the following characters:

' , ( ) = # ! \$ % \ ~ + - & | < > [ ] ;

For example:

```
$ERRORPRINT ("ERROR (S) .OUT")
```

Errorprint files that do not contain any of the characters above should appear as follows:

```
$ERRORPRINT (ERROR.OUT)
```

# GEN/NOGEN/GENONLY

## Syntax

<b>Command Line</b>	GEN NOGEN GENONLY
<b>Source File</b>	GEN NOGEN GENONLY
<b>Abbreviation</b>	GE NOGE GO

## Default

GENONLY

## Type

General

## Discussion

The `GEN`, `GENONLY`, and `NOGEN` controls determine the mode of listing assembly source text, macro calls, and macro expansion text in the print file, as follows:

- `GEN` produces a listing that contains all source text, all macro calls, all macro expansions (i.e., the macro text), and object code.
- `GENONLY` produces a listing that contains source file nonmacro text and the final resulting text of all macros called, but omits the actual macro calls. Object code generated inside any macro calls is listed.
- `NOGEN` produces a listing that contains only the source file text (macro definitions and calls), not the macro expansions. Object code, if any, is listed after the line containing the macro call.

`GEN` produces the most complete and continuous source listing because it provides a trace of the entire macro call and expansion process. Expansions appear on the line below the call, indented to the same column as the call. (Horizontal tabs in macro calls or expansion lines are not expanded.)

This makes the `GEN` listing useful for debugging macros. However, `GEN` may produce an inconveniently large print file for programs that contain many macro calls.

Both the `NOMACRO` and `NOPRINT` controls override the `GEN`, `GENONLY`, and `NOGEN` controls. When any combination of the three controls -- `GEN`, `NOGEN`, and `GENONLY` -- appears on the same control line within the source file, the last setting takes effect.

### Example

Only one of the `GEN`, `GENONLY`, or `NOGEN` controls can be in effect at one time in the source listing, although you can specify the controls at selected points to change the listing mode. The following example shows how the macro `MAC` is called in each of the three modes:

- In `GEN` mode, line 8, the listing includes the macro call and its expansion.
- In `GENONLY` mode, line 17, the call to `MAC (%MAC (4, 5, 6))` is suppressed, but the resultant text is listed.
- In `NOGEN` mode, line 22, only the call to `MAC` is listed. The expansion lines are skipped.

LOC	OBJ	LINE	SOURCE
		1	NAME XXX
		2	\$NOGEN
		3	%*DEFINE (MAC (A,B,C) ) (DW %A
		4	DW %B
		5	DW %C
		6	)
		7	DATA SEGMENT RW
-----		8 +1	\$GEN
		9	%MAC (1,2,3)
00000000	0100	10 +1	DW %A
		11 +2	1
00000002	0200	12 +1	DW %B
		13 +2	2
00000004	0300	14 +1	DW %C
		15 +2	3
		16 +1	
		17 +1	\$GENONLY
00000006	0400	18 +2	DW 4
00000008	0500	19 +2	DW 5
0000000A	0600	20 +2	DW 6
		21 +1	
		22	\$NOGEN
		23	%MAC (7,8,9)
0000000C	0700		
0000000E	0800		
00000010	0900		
-----		24	DATA ENDS
		25	END

**Figure 3-1. Sample Listing for GEN/NOGEN/GENONLY**

## INCLUDE

### Syntax

<b>Command Line</b>	<code>INCLUDE (file-spec)</code>
<b>Source File</b>	<code>INCLUDE (file-spec)</code>
<b>Abbreviation</b>	<code>IC</code>

### Type

General

### Discussion

`INCLUDE` directs the assembler to insert the contents of a file into the source file. If `INCLUDE` appears in the invocation line, the contents of the include file are inserted before the contents of the main source file. If `INCLUDE` appears in a control line, input from the include file begins following the control line and continues until the end of the include file is reached. At that time, input resumes from the file that was being processed when the `INCLUDE` control was encountered.

`INCLUDE` need not be the last command in a control line; however, it does not take effect until the end of the control line is reached. The following restrictions govern the use of `INCLUDE`:

- Only one `INCLUDE` control is allowed per line.
- No more than 64 combinations of macro calls and `INCLUDE` controls can be in effect at the same time in any one module.
- The maximum nesting level for included files is nine.
- An included file can contain lines specifying primary controls.

Included files specified in the source file must be enclosed within quotation marks if they contain spaces or any of the following characters:

```
' , ( ) = # ! $ % \ ~ + - & | < > [ ]
```

For example:

```
$INCLUDE ("Clude(s).INC")  
$INCLUDE ("Lot#4.Inc")
```

---

# LIST

## Syntax

<b>Command Line</b>	LIST NOLIST
<b>Source File</b>	LIST NOLIST
<b>Abbreviation</b>	LI NOLI

## Default

LIST

## Type

General

## Discussion

LIST directs the assembler to resume the source listing in the print file with the next source line read. NOLIST suppresses the listing, beginning with the next line read, until the next occurrence (if any) of LIST. Specifying NOLIST at invocation suppresses the listing, beginning with the first line.

The following is a list of interactions between LIST/NOLIST and other assembler controls:

- NOPRINT, XREF, and SYMBOLS override the LIST/NOLIST controls.
- PRINT does not override NOLIST. If both NOLIST and PRINT are in effect, only the assembler messages for source lines containing errors appear in the print file. Otherwise, the file contains only a header (assuming SYMBOLS or XREF is not in effect).
- If an EJECT control appears in a line suppressed by NOLIST, a new page begins when the listing is started again by LIST.
- NOLIST affects the setting of the PAGELength control only if NOLIST is still in effect when the end of the source listing is reached. If NOLIST suspends the listing in the middle of a page and a subsequent LIST begins the listing again, source lines are added to the page until it reaches the specified length.

## MACRO

### Syntax

<b>Command Line</b>	MACRO NOMACRO control
<b>Source File</b>	MACRO [ ( <i>parameter</i> ) ] NOMACRO
<b>Abbreviation</b>	MR NOMR

### Default

MACRO

### Type

Primary

### Discussion

The `MACRO` control directs the assembler to recognize and process macros.

Macros can appear anywhere in the source file, including control lines. Refer to Chapter 2 for an example of a macro call within a control line. In effect, any occurrence of the macro metacharacter (%) by default) in the source is considered a macro call. The parameter has no effect for the assembler but is allowed for compatibility with existing ASM286 files.

Macros can also appear in the invocation line. Use the `%macro-string` statement.

See also:     The `%macro-string` statement, Chapter 2  
              macro processing language, *ASM386 Assembly Language Reference*

`NOMACRO` directs the assembler to scan macros only as normal assembly language text, which usually causes assembler errors. It may speed up the assembly if no macros are used and the `NOMACRO` control is in effect.

`NOMACRO` overrides the `GEN/GENONLY/NOGEN` controls.

## MOD386/MOD376/MOD486

### Syntax

<b>Command Line</b>	MOD386 MOD376 MOD486
<b>Source File</b>	MOD386 MOD376 MOD486

### Default

MOD386

### Type

Primary

### Discussion

The MOD386, MOD376, and MOD486 controls direct the assembler to ensure that the input file meets the requirements of the Intel386, 376, and Intel486 processors, respectively. By default, the assembler accepts assembly language source code that executes on the Intel386 processor.

The Intel486 or Pentium processor architecture is fully compatible with the Intel386 processor architecture. All Intel386 processor modes are available to the Intel486 or Pentium processor. The Intel486 processor also has an expanded instruction set and additional registers which are supported by the assembler with the MOD486 control specified.

The MOD486 primary control provides the following support for Intel486 microprocessor software development using ASM386 V4.0:

- Enables the test registers TR3, TR4, and TR5 which are defined on the Intel486 microprocessor.
- Enables the forms of the MOV instruction to load and store the TR3, TR4, and TR5 registers.
- Generates machine code for all forms of the Intel486 microprocessor instructions.

See also: Differences between Intel386 and Intel486 processors, *ASM386 Assembly Language Reference*

The 376 processor architecture is a subset of the Intel386 processor architecture: the 32-bit protected mode is available, but real address mode, virtual 8086 mode, and paging are not available. The segmentation-based memory management and protection features are available on the 376 processor. 286 processor call, interrupt, or trap gates or 286 processor TSSs are not supported on the 376 processor.

See also: Differences between the 376 and Intel386 processors, *ASM386 Assembly Language Reference*

When assembling for the 376 processor, make sure the input file contains only `USE32` code or stack segments. `USE16` code segments are not executable on the 376 processor. The assembler issues an error message if the `USE16` segment directive is in effect for a code or a stack segment; `USE16` data segments may be included in the input file. An error is also issued if the `USE16` keyword is used in an `EXTRN` directive of type `NEAR` or `FAR`.

Because the 376 processor has a 24-bit address bus, a segment must be no larger than 16 megabytes. The assembler issues a warning when you specify `MOD376` and the source file contains a segment exceeding 16 megabytes.

See also: Errors and warnings, Appendix A

## N387/N287

### Syntax

<b>Command Line</b>	N387 N287
<b>Source File</b>	N387 N287

### Default

N387

### Type

Primary

### Discussion

By default, the assembler generates code for Intel387 floating-point coprocessor instructions. The Intel387 floating-point coprocessor includes all the instructions for the Intel287 plus `FSINCOS`, `FSIN`, `FCOS`, `FUCOMPP`, `FUCOM`, `FUCOMP`, and `FPREML`.

`N287` directs the assembler to detect the instructions not supported on the Intel287 and to issue an error message for each line that contains an instruction unique to the Intel387 floating-point coprocessor.

See also: Instructions for the Intel387 floating-point coprocessor, *ASM386 Assembly Language Reference*

## OBJECT

### Syntax

<b>Command Line</b>	OBJECT [ ( <i>file-spec</i> ) ] NOBJECT
<b>Source File</b>	OBJECT [ ( <i>file-spec</i> ) ] NOBJECT
<b>Abbreviation</b>	OJ NOOJ

### Default

NOBJECT

### Type

Primary

### Discussion

OBJECT directs the assembler to create an object file during assembly of the specified source file. If severe errors are found, the object file is not produced.

See also: Errors that affect the creation of an object file, Appendix A

If you do not specify NOBJECT or you specify OBJECT without the object-file parameter, the assembler creates an object file with the same file name as the source file and the extension OBJ.

NOBJECT directs the assembler not to create an object file.

NOBJECT overrides the DEBUG/NODEBUG and TYPE/NOTYPE controls.

Object file names specified in the source file must be enclosed within quotation marks if they contain spaces or any of the following characters:

' , ( ) = # ! \$ % \ ~ + - & [ < > [ ] ;

For example:

```
$OBJECT ("TOP (s) .OBJ")
```

# PAGELENGTH

## Syntax

<b>Command Line</b>	PAGELENGTH ( <i>length</i> )
<b>Source File</b>	PAGELENGTH ( <i>length</i> )
<b>Abbreviation</b>	PL

## Default

PAGELENGTH (60)

## Type

Primary

## Discussion

PAGELENGTH directs the assembler to create print file pages of a specified length. The value of *length* may be an unsigned decimal integer from 10 to 65535 representing the number of lines per page of the print file. The total number of lines per page includes any header lines on the page. The minimum page length is 10 lines.

PAGELENGTH is ignored if the NOPRINT or NOPAGING control is in effect.

NOLIST affects the setting of PAGELENGTH only if NOLIST is in effect when the end of the source listing is reached. If NOLIST suspends the listing in the middle of a page and a subsequent LIST begins the listing again, source lines are added to that page until it reaches the specified length.

## PAGEWIDTH

### Syntax

<b>Command Line</b>	<code>PAGEWIDTH (<i>width</i>)</code>
<b>Source File</b>	<code>PAGEWIDTH (<i>width</i>)</code>
<b>Abbreviation</b>	<code>PW</code>

### Default

`PAGEWIDTH (120)`

### Type

Primary

### Discussion

`PAGEWIDTH` directs the assembler to create print and errorprint file pages of a specified width. The value of *width* may be an unsigned decimal integer that specifies the number of characters on a line of the print and errorprint files.

The minimum page width is 60 characters; the maximum is 132.

The `NOPRINT` control overrides `PAGEWIDTH`.

# PAGING

## Syntax

<b>Command Line</b>	PAGING NOPAGING
<b>Source File</b>	PAGING NOPAGING
<b>Abbreviation</b>	PI NOPI

## Default

PAGING

## Type

Primary

## Discussion

PAGING directs the assembler to format the print file into pages, as follows:

- Every page is initiated with a form feed character.
- Each page begins with a header containing the assembler name, title, date, and page number.
- The symbol table listing, if present, begins on a new page, following the source listing.

The length of the page depends on the setting of the PAGELENGTH control.

NOPAGING prevents the print file from being paged. Instead, a single header is printed at the beginning of the file and the listing is continuous until the symbol table (if any), which is separated from the source listing by four blank lines.

The following is a list of interactions between PAGING/NOPAGING and other assembler controls:

- NOPRINT overrides PAGING and NOPAGING.
- NOPAGING overrides PAGELENGTH.
- NOPAGING overrides EJECT.

## PRINT

### Syntax

<b>Command Line</b>	PRINT [ ( <i>file-spec</i> ) ] NOPRINT
<b>Source File</b>	PRINT [ ( <i>file-spec</i> ) ] NOPRINT
<b>Abbreviation</b>	PR NOPR

### Default

```
PRINT source-file.LST
```

### Type

Primary

### Discussion

PRINT directs the assembler to create a source listing during assembly and write it to the listing file or to the screen. If you do not specify NOPRINT or you specify PRINT without the file-spec parameter, the source listing appears in a file with the same file specification as the source file with the LST extension.

NOPRINT directs the assembler not to create a source listing.

NOPRINT overrides all controls affecting the print file (EJECT, SYMBOLS, etc.), but does not affect controls related to the object file (DEBUG, TYPE, etc.).

If NOLIST is used while PRINT is in effect, the listing contains only the header, error messages, and those source lines containing errors. Correct source lines do not appear unless the listing is begun again by the LIST control.

Print files specified in the source file must be enclosed within quotation characters if they contain spaces or any of the following characters:

```
' , ( ) = # ! $ % \ ~ + - & | < > [ ] ;
```

For example:

```
$PRINT ("New(s) .LST")
```

# SAVE/RESTORE

## Syntax

<b>Source File</b>	SAVE RESTORE
<b>Abbreviation</b>	SA RS

## Type

General

## Discussion

SAVE directs the assembler to save the current settings of the LIST/NOLIST and GEN/GENONLY/NOGEN controls on a stack. The current setting is the setting in effect at the beginning of the SAVE control line. RESTORE specifies that the most recently saved settings on the stack become the current settings of those controls. SAVE and RESTORE are not allowed on the command line. The maximum nesting level of SAVES is eight.

The SAVE and RESTORE controls do not function correctly when used under the following conditions:

- Fewer than two lines exist between the SAVE followed by RESTORE.
- The control lines containing SAVE/RESTORE are in an include file.
- SAVE or RESTORE is combined with either the GEN or NOGEN control.

## Example

SAVE and RESTORE can be used to regulate the listing of macros. For example, you may want a listing that contains both macro calls and their results. This listing would be comparable to a combination of the results of the NOGEN and GEN controls. The call line is listed in NOGEN mode; both the call line and the expansion are listed in GEN mode. The following example shows the use of SAVE/RESTORE to regulate the listing of a macro MAC for two calls.

## SAVE/RESTORE

---

```
LOC      OBJ      LINE      SOURCE
          1      NAME SAVE_TEST
          2
          3 +1     $GEN
          4 +1     $$SAVE ;SAVES GEN'S SETTING ON STACK
          5       %*DEFINE(MAC(A, B) ) (
          6       MOV AX, %A
          7       MOV BX, %B
          8       )
-----
          9      DATA SEGMENT RW
00000000 0400    10      D1 DW 4
-----
          11     DATA ENDS
-----
          12     CODE SEGMENT EO
          13     ASSUME DS:DATA
          14     $NOGEN
          15     ;NOGEN SETTING IS IN EFFECT
          16     FOR NEXT MACRO CALL
          17     %MAC (40H, 50H)
00000000 66B84000
00000004 66B85000
          18     $RESTORE ;GEN SETTING FROM STACK
          19     IS IN EFFECT FOR NEXT CALL
          20     %MAC (70H, 80H)
          21
00000008 66B8700C
          22     MOV AX, %A
          23     70H
0000000C 66BB8000
          24     MOV BX, %8
          25     80H
          26
-----
          27     CODE ENDS
          28     END
ASSEMBLY COMPLETE, NO WARNINGS, NO ERRORS.
```

**Figure 3-2. Sample Listing for SAVE/RESTORE**

# SYMBOLS

## Syntax

<b>Command Line</b>	SYMBOLS NOSYMBOLS
<b>Source File</b>	SYMBOLS NOSYMBOLS
<b>Abbreviation</b>	SB NOSB

## Default

NOSYMBOLS

## Type

Primary

## Discussion

`SYMBOLS` directs the assembler to append a symbol table to the source listing in the print file. The symbol table is an alphabetical list of all assembler identifiers defined within the source, with their attributes. Assembler identifiers do not include macro identifiers.

See also: Symbol table, Chapter 4

`NOSYMBOLS` directs the assembler to suppress the symbol table.

`NOPRINT` overrides `SYMBOLS`; `XREF` overrides `NOSYMBOLS`.

## TITLE

### Syntax

<b>Command Line</b>	<code>TITLE(<i>title</i>)</code>
<b>Source File</b>	<code>TITLE(<i>title</i>)</code>
<b>Abbreviation</b>	<code>TT</code>

### Default

`TITLE(module-name)`

### Type

General (source file)  
Primary (command line)

### Discussion

`TITLE` directs the assembler to place a character string in the header on the first line of each page of the print file.

In the command line, `TITLE` functions as a primary control and sets the title for each page of the file. When specified in a control line, `TITLE` functions as a general control. The specified title appears on the page where the `TITLE` control line occurs and on all subsequent pages until changed by another `TITLE` control.

`TITLE` does not cause a new page to start. The `EJECT` control or normal paging determine the start of a new page.

The maximum title length is 60 printable ASCII characters. If the title does not fit within the specified page width, the assembler truncates the title on the right. No error message is generated for titles up to 80 characters. Titles over 80 characters long generate incorrect error messages:

```
ERROR #520:  BAD CONTROL PARAMETER
ERROR #612:  EXPECTED A RIGHT PARENTHESIS
```

Titles specified in control lines must be enclosed within quotation marks if they contain spaces or any of the following special characters:

' , ( ) = # ! \$ % \ ~ + - & | < > [ ]

For example:

```
$TITLE("Section 2")
```

If the title itself contains a quotation character or apostrophe, enclose the title in the other type of quote mark. For example:

```
$TITLE('Nancy"s')  
$TITLE("Nancy's")
```

In the absence of any `TITLE` controls, the assembler uses the module name specified with the `NAME` directive as the title.

`NOPRINT` overrides `TITLE`. The `NOPAGING` control overrides `TITLE` controls that appear after the primary control lines, because no new pages are created.

Use of the `TITLE` control on the command line overrides use of the `TITLE` control on the primary control line in the source file.

## TYPE

### Syntax

<b>Command Line</b>	TYPE NOTYPE
<b>Source File</b>	TYPE NOTYPE
<b>Abbreviation</b>	TY NOTY

### Default

NOTYPE

### Type

Primary

### Discussion

TYPE directs the assembler to include type information about the PUBLIC variables and labels in the symbol records of the object module. NOTYPE directs the assembler to omit type information from the object module. The NOOBJECT control overrides TYPE.

Type information for variables declared PUBLIC is used primarily to assist debuggers in displaying symbols. Although the type produced for a variable may not exactly correspond to the intended contents of that memory location, the type is sufficient to specify the number of bytes to be displayed for the variable. Also, in the case of an array or structure, the format and size associated with the symbol are included.

The type information produced by the assembler can also be used for inter-module type checking by BND386, the binder for processor modules. BND386 compares the use of variables in different modules to ensure that every use of a variable is consistent with its type. However, the utility of TYPE is limited because the assembler does not produce type information for external symbols, nor does it support perfect type matching with high-level languages.

See also: *Assembler data types, ASM386 Assembly Language Reference*

## USE32/USE16

### Syntax

<b>Command Line</b>	USE32 USE16
<b>Source File</b>	USE32 USE16
<b>Abbreviation</b>	U32 U16

### Default

USE32

### Type

Primary

### Discussion

USE16 directs the assembler to generate 16-bit addresses and offsets, as well as the appropriate operand sizes and address mode override prefixes. In this mode, which is compatible with ASM286, the assembler supports a maximum segment size of 64K. If USE16 is in effect, the assembler can translate ASM286 assembly language modules without source modification.

ASM386 performs 32-bit arithmetic even when you specify USE16. ASM386 does not support register expressions that use scale with USE16.

USE32, the default, directs the assembler to generate 32-bit addresses and offsets, as well as the appropriate operand sizes and address mode override prefixes. In this context, the assembler supports a maximum segment size of 4 gigabytes.

The assembly language includes the USE16 and USE32 segment USE attributes that perform the same functions as the USE16 and USE32 controls, respectively. USE32 is the default.

The following rules also apply:

- Only one member of the control pair `USE32` and `USE16` can be specified in the invocation line, that is, if `USE16` is specified `USE32` cannot be specified.
- If both `USE16` and `USE32` are specified in source control lines, the last one specified is in effect.

See also: Segment `USE` attributes, *ASM386 Assembly Language Reference*

# WORKFILES

## Syntax

<b>Command Line</b>	<code>WORKFILES (dir1[, dir2])</code>
<b>Source File</b>	<code>WORKFILES (dir1[, dir2])</code>
<b>Abbreviation</b>	WF

## Default

`WORKFILES (:WORK:, :WORK:)`

## Type

Primary

## Discussion

`WORKFILES` specifies logical names for devices or directories for storage of assembler-created temporary files. These intermediate files are deleted at the end of assembly. A single name may be specified as the parameter; this is equivalent to specifying that name twice.

This is provided for compatibility with earlier assemblers.

See also: Work Files, Chapter 2

## XREF

### Syntax

<b>Command Line</b>	XREF NOXREF
<b>Source File</b>	XREF NOXREF
<b>Abbreviation</b>	XR NOXR

### Default

NOXREF

### Type

Primary

### Discussion

XREF directs the assembler to append a symbol table listing, including cross-reference line numbers, to the source listing in the print file. This table has the same format as the table produced by the SYMBOLES control, with an additional field entitled XREFS. The XREFS field contains the numbers of the lines in which a symbol is defined, referenced, or purged.

See also: Symbol table, Chapter 4

NOXREF directs the assembler to omit the cross-referenced field from the print file.

XREF overrides the SYMBOLES and NOSYMBOLS controls. NOPRINT overrides XREF.



The listing, sometimes referred to as the print file, provides information on the assembly of a module, such as a listing of the source code and object code, and any errors or warnings produced by the assembler. This chapter describes the fields of information in the print file and the file's optional symbol table listing.

Figure 4-1 is a sample listing for an assembler module named `MYPROG`, which contains errors to illustrate the assembler error reporting. The four main fields of information in the print file are `LOC` (location counter), `OBJ` (object code), `LINE` (line number), and `SOURCE` (source text). Other kinds of information may appear in a print file, depending on the nature of the source program. In general, information generated by the assembler appears to the left of the line number and source code appears to the right of the line number.

## The Default Print File

If you do not specify any assembler controls that govern the format of the print file, the file has the following characteristics:

- The file specification is the source file's name with `LST` extension.
- The file is divided into pages 60 lines long and 120 characters wide. The first line of each page contains the assembler name, the title (the module name specified with the `NAME` directive), the time and date, and the page number.

For macros, the file contains the source file's text and the final resulting text of all macros, but not the actual macro calls. All object code generated inside macro calls is listed.

system-id Intel386 MACRO ASSEMBLER Vx.y ASSEMBLY OF MODULE MYPROG  
 OBJECT MODULE PLACED IN MYPROG.OBJ  
 ASSEMBLER INVOKED BY: ASM386 SYMBOLS PAGESWIDTH 73 MYPROG.ASM

LOC	OBJ	LINE	SOURCE
		1	NAME MYPROG
		2	
REG		3	COUNT EQU CX
-0800		4	IVAL EQU -800H
0100		5	AR_SIZE EQU 100H
#		6	R17 RECORD SIGN:1, LOW7:7
		7	
		8	EXTRN SYSTEM:FAR
		9	PUBLIC INIT
-----		10	FLOAT STRUC
0000000		11	EXPONENT DB 0
0000001		12	MANTISSA DD 0
-----		13	FLOAT ENDS
		14	
C MACRO		15	CODEMACRO D7 VALUE:D
#		16	R17 <0, VALUE>
#		17	ENDM
		18	
-----		19	STSEG STACKSEG 100
		20	
-----		21	DATA SEGMENT RW USE32
00000000 03		22	INITIAL FLOAT <3,5>
00000001 05000000			
00000005 03		23	TOP DB 3, 10
00000006 0A			
		24	WOMBAT
***-----^			
***			ERROR #1 IN 24, SYNTAX ERROR

**Figure 4-1. Sample Print File Page**

```

00000007 414243          25  STRNG  DB  'ABC'
0000000A (10           26           DW 10 DUP (1,3,44H)
          0100
          0300
          4400
          )
00000046 05000000      R 27  ITOP  DW TOP
0000004A 46000000      R 28  IITOP DD ITOP
0000004E 07           29           D7 07H
0000004F ----      R 30  ES_SEL DW EXTRA
-----
          31  DATA  ENDS
          32
-----
          33  EXTRA  SEGMENT RW USE32
AAAAAAAA          34           ORG 0AAAAAAAAH
AAAAAAAA (256       35  ARRAY  DD AR_SIZE DUP (?)
          ????????)
-----
          36  EXTRA  ENDS
          37
AAAAAAB4: []      38  AR1BX  EQU ES:ARRAY1
          [EBX+10]
          39
-----
          40  CODE   SEGMENT ER
          41           ASSUME DS:DATA
          42
00000000 ----      R 43  DS_SEL DW DATA
          44
00000002          45  INIT   PROC FAR
00000002 66B9F600    46           MOV COUNT,AR_SIZE - 10

```

**Figure 4-1. Sample Print File Page (continued)**

```

00000006 6689CB          47          MOV BX, COUNT
00000009                48      INITLOOP:
00000009 26C783B4AAAAAA00F8FF
                                R 49          MOV AR1BX, IVAL FF
00000014 E2F3                50          LOOP INITLOOP
00000016 CB                51          RET
00000017                52      INIT   ENDP
                                53
00000017 2E8E1D00000000      R 54      START: MOV DS, DS_SEL
0000001E 8E054F000000      R 55          MOV ES, ES_SEL
00000024 9A02000000----      R 56          CALL INIT
0000002B 9A00000000----      E 57          CALL SYSTEM
-----                58      CODE   ENDS
                                59
                                60      CODE_16 SEGMENT EO
                                USE16
0000 B8----                R 61      MOV AX, EXTRA
0003 8ECO                62      MOV ES, AX
0005 666726C7843BAAAAAA
                                R 63      MOV ES:ARRAY1[EBX][EDI],
                                0FFFFFFFH  FFFFFFFF
-----                64      CODE_16 ENDS
                                65
                                66 +1 $INCLUDE
                                (WOMBAT.INC)
                                =1 67      WOMBAT
*** -----^
*** ERROR #1 IN (WOMBAT.INC, LINE 67), SYNTAX ERROR
                                68      END START, DS:DATA, SS:STSEG
                                69

```

**Figure 4-1. Sample Print File Page (continued)**

## Print File Headers

The first line of each page of the print file contains the assembler name, the title (either the module name or the name you specified with the `TITLE` control), the time and date determined by the operating system, and the page number. The first page contains an additional header in the following form:

```
system-id Intel386 MACRO ASSEMBLER Vx.y  
ASSEMBLY OF MODULE module-name  
OBJECT MODULE PLACED IN object-file  
ASSEMBLER INVOKED BY: ASM386 [controls] source-file
```

If no object file is requested or if errors prevent an object module from being created, the second line of the header contains a message `NO OBJECT FILE REQUESTED` or `NO OBJECT MODULE CREATED`. The last header line lists the controls used in the assembler invocation.

See also:    Command Syntax, Chapter 2

## Location Counter (LOC)

The program location counters track the current offset within the segment being assembled. The `LOC` field contains the location counter. For code in `USE32` segments, the location counter is an eight-digit hexadecimal number. For code in `USE16` segments, the upper four digits are blank and the location counter appears in the last four columns.

For source lines that generate object code and for labels (`LABEL` or `PROC`), the `LOC` field contains the location counter value effective at the beginning of the line.

For source lines containing the `ORG` directive, the `LOC` field contains the new value specified by the `ORG` statement.

The `LOC` field is blank for lines containing comments, directives, controls, macro definitions, or record definitions. If the object code for a source statement appears on more than one line, all other fields of the continued lines are blank, including the location counter.

For record definitions, a pound sign (`#`) appears in the rightmost column of the `LOC` field to signal that assembly is not taking place. For example:

```
#                6 R17    RECORDSIGN:1, LOW7:7
```

When a `STRUC`, `SEGMENT`, `STACKSEG`, or `ENDS` line has been coded, the `LOC` field contains the notation `-----`. For a `USE16 SEGMENT`, the notation is `----`. The notation signals a break in the flow of the location counter. For example:

```
-----          21 DATA  SEGMENT RW  USE32
```

## Equated Symbols (EQU Directive)

Equated symbols are on the left-hand side of a statement containing the `EQU` directive. Information about equated symbols appears in the last half of the `LOC` field and the first half of the `OBJ` field, starting in column three.

If the symbol is equated to a variable or label, this area contains the hexadecimal offset of the symbol. Variable or label equates can have segment override and indexing attributes. A colon (`:`) after the offset indicates an override attribute; brackets (`[ ]`) indicate an indexing attribute, as in the following example:

```
AAAAAAB4:[]    38 AR1BX  EQU ES:ARRAY1 [EBX+10]
```

If the symbol is equated to a number, this area contains the hexadecimal value of the number. If the symbol is equated to one of the following, the item's identifier appears in this area:

<b>Item</b>	<b>Identifier</b>
register	REG
macro	MACRO
codemacro	C MACRO
segment	SEGMENT
external variable	EXTRN
record	RECORD
record field	RFIELD
structure	STRUC
structure field	SFIELD
instruction	INSTRUCTION
keyword	KEYWORD

For example, the `LOC` field contents for a symbol equated to a register are shown in this line:

```
REG          3    COUNT EQU CX
```

## Floating-point Stack Elements (ST)

A floating-point stack element is indicated by `ST(i)`, where *i* is the numerical index value beginning in column 3 if the element is indexed, or by `ST` if the index is 0.

## COMM Variables and Labels

The word `COMM` appears in columns 3 through 6 for each line of a data definition given the `COMM` attribute with the `COMM` statement.

## Object Code (OBJ)

The object code is displayed as hexadecimal starting in column 10 and is filled as follows:

- The maximum size of an instruction is 15 bytes, even if all five prefix bytes are present.
- The field contains the notation ---- if segment selector values were assembled.

If an assembler statement spans several lines, object code produced for completed constructs on a continued line prints with the continued line. The assembler does not wait until a statement is completed to display all the object code.

Whenever a DUP field begins, a left parenthesis appears in the left column of the OBJ field, followed by the count in decimal numbers. The content bytes are left justified on the lines that follow, ending with a right parenthesis in the leftmost column. For example:

```
0000000A (10      25      DW 10  DUP  (1,3,44H)
          0100
          0300
          4400
          )
```

For nested DUPs, the left parenthesis, number, and the right parenthesis are indented one column for each nesting level, but the content bytes are never indented.

## Relocatable or External Code (R, E)

The object code can be followed by a relocation indicator, which is the letter R if relocatable object code is generated on the current line, or the letter E if external code is generated. The E appears on lines containing code that is both external and relocatable. For example:

```
00000019 9A02000000---- R 55          CALL  INIT
00000020 9A00000000---- E 56          CALL  SYSTEM
```

## Include Nesting Indicator (=)

An equal sign (=) followed by a number from 1 to 9 appears between the object code and the line number for all source lines that come from include files. The number indicates the level of nesting. An asterisk (\*) appears if the include nesting level exceeds 9.

```
        66      $INCLUDE  (WOMBAT.INC)
=1 67      WOMBAT
```

## Line Numbers (LINE)

The `LINE` field is five characters long. The line numbers begin with 1 and are incremented for every source or macro expansion line listed.

## Macro Expansion Indicator (+)

The first column following the line number field of a macro expansion line contains a plus (+). The next two columns contain a number that indicates the nesting level of the macro, except for expansions, in which case these two columns are blank.

```
=1 85      %INC1 (EXAMPLE, SIMPLE)
=1 86 +1
=1 87 +1  ;THIS %NOUN
=1 88 +2      EXAMPLE IS %ADJ
=1 89 +2                SIMPLE
```

## Source Statements (SOURCE)

The source text is a copy of the source line of macro-generated text (as determined by the setting of the `GEN/NOGEN/GENONLY` controls).

Tabs in your source are reproduced so that the source text looks the same in the listing. If the `GEN` control is in effect, tabs are not expanded in lines containing macro calls (or parts of calls) or in macro expansion lines; instead, tabs appear as single spaces.

If a source statement exceeds the specified page width, it continues on the next line and the continued lines contain only source text, as shown:

```
00000009 6626C783B4AAAAA00F850      INITLOOP:MOV ES:ARRAY1
                                [EBX+10], IVAL
```

An error or warning message appears immediately after an erroneous line. The message contains an error or warning number, a listing line number, a pass number (if other than the first pass), and a brief description.

See also:    Interpreting and correcting errors, Appendix A

## The Symbol Table

The DOS symbol table capacity is approximately 4500 seven-character symbols when expanded memory and at least 568K conventional memory are available.

If the `SYMBOLS` or `XREF` control is in effect, the symbol table follows the source listing. `SYMBOLS` generates the standard table; `XREF` generates the same table with the addition of the numbers of each line in which a particular symbol was referenced. The example in Figure 4-2 was generated with `SYMBOLS`.

The symbols are in alphabetical order using the ASCII character order, except for the underscore (`_`), which comes first. Reserved names are not included unless they have been redefined or purged.

If the `PAGING` control is in effect, the symbol table begins on a new page; otherwise, it is separated from the source listing by four blank lines. The final message of the print file, which signals the end of assembly and shows the number of warnings and errors, appears after the symbol table.

See also:     Symbol table fields and examples, Chapter 4

## SYMBOL TABLE LISTING

```

-----
NAME          TYPE          VALUE          ATTRIBUTES
AR1BX.....V  DWORD          AAAAAAB4H     ES:[EBX]
ARRAY1.....V  DWORD          AAAAAAAAH     (256) EXTRA ES:
AR_SIZE....NUMBER          0100H
CODE.....SEGMENT          SIZE=00000032H ER USE32
CODE_16....SEGMENT          SIZE=00000013H E0 USE32
COUNT.....REG          CX
D7.....C      MACRO          DEFS=1
DATA.....SEGMENT          SIZE=00000051H RW USE32
DS_SEL ....V  WORD          00000000H     CODE
ES_SEL ....V  WORD          0000004FH     DATA
EXPONENT...V  BYTE          00000000H     SFIELD
EXTRA.....SEGMENT          SIZE=AAAAAEAAH RW USE32
FLOAT.....STRUC          SIZE=00000005H #FIELDS=2
IITOP.....V  DWORD          0000004AH     DATA
INIT.....P    FAR          00000002H     CODE WC=0 PUBLIC
INITIAL....V  STRUC          00000000H     DATA
INITLOOP...L  NEAR          00000009H
ITOP.....V  DWORD          00000046H     DATA
IVAL.....NUMBER          FFFF800H
LOW7.....R    FIELD          00000000H     WIDTH=7
MANTISSA...V  DWORD          00000000H     SFIELD
R17.....RECORD          SIZE=1 WIDTH=8 DEFAULT=00H
SIGN.....RFIELD          00000007H     WIDTH=1
START.....L    NEAR          00000017H
STRNG.....V  BYTE          00000007H     (3) DATA
STSEG.....STACK          SIZE=00000064H RW PUBLIC USE32
SYSTEM....L    FAR          00000000H     EXTRN
TOP.....V  BYTE          00000005H     (2) DATA
VALUE.....-----          --UNDEFINED--
WOMBAT.....-----          --UNDEFINED--

```

END OF SYMBOL TABLE LISTING

ASSEMBLY COMPLETE, NO WARNINGS, 2 ERRORS

**Figure 4-2. Sample Symbol Table**

## Symbol Table Fields

The fields of the symbol table are NAME, TYPE, VALUE, ATTRIBUTES. The XREF field occurs when the table is generated by the XREF control.

In the NAME field, the name of the symbol appears as it was entered. The width of the field depends on the size of the longest name in the table, up to a maximum of 31 unique characters. Spaces and periods are added to fill out the field for short names.

The TYPE field appears after the NAME field. The possible types are described in the following sections.

The VALUE field contains the symbol's value, which is eight hexadecimal digits long for symbols within USE32 segments or four digits for symbols within USE16 segments. Not every type of symbol has a value displayed. Except for floating-point stack elements and register names, all displayed values are in hexadecimal.

The ATTRIBUTES field contains other pertinent information about the symbol, depending on its type. For example, the ATTRIBUTES field for a codemacro contains the number of its definitions.

The last part of the ATTRIBUTES field contains cross-reference information if the XREF control is in effect. The field contains one line number for each appearance of the symbol in the program. A pound sign (#) follows the number if the line contains a definition of the symbol. A P follows the number if the symbol was purged on that line. If the ATTRIBUTES/XREF field overflows a line, the field continues on subsequent lines.

The assembler lists as many cross-references as available memory allows. If memory is exhausted while the assembler is sorting cross-references, an error message appears at the beginning of the symbol table.

### Code macros (C MACRO)

C MACRO in the TYPE field indicates a codemacro. The VALUE field is blank. The ATTRIBUTES field contains the notation `DEFS=n`, where *n* is the number of the codemacro's definitions.

### Public and External Symbols (PUBLIC, EXTRN)

Public symbols have the PUBLIC attribute after all other attributes.

The TYPE field for external symbols contains the type that appears in the EXTRN statement. The VALUE field always contains `00000000H` and the ATTRIBUTES field contains EXTRN.

## Floating-point Stack Elements (F STACK)

`F STACK` in the `TYPE` field indicates a floating-point stack element. The `VALUE` field contains `ST(i)` if the element is indexed, where *i* is the numeric index value, or `ST` if the element is not indexed. The `ATTRIBUTES` field is blank.

## Instruction

`INSTRUCTION` in the `TYPE` field indicates an instruction. The `VALUE` field contains the name of the instruction. The `ATTRIBUTE` field is blank.

## Keyword

`KEYWORD` in the `TYPE` field indicates a keyword. The `VALUE` field contains the name of the keyword. The `ATTRIBUTE` field is blank.

## Labels (L NEAR, L FAR)

`L FAR` and `L NEAR` in the `TYPE` field indicate labels. The `VALUE` field contains the label's offset. The `ATTRIBUTES` field contains the segment name, if known.

## Numbers (NUMBER)

`NUMBER` in the `TYPE` field indicates a number. The `VALUE` field contains a hexadecimal number, which can be negative only for an integer. The `ATTRIBUTES` field contains `RELOC` for symbols equated to relocatable numbers and `REAL` for symbols equated to floating point numbers.

## Procedures (P NEAR, P FAR)

Procedures are identified by `P NEAR` or `P FAR` in the `TYPE` field. The `ATTRIBUTES` field contains its size in bytes, the segment name, and the word count, if one was specified.

## Records and Record Fields (RECORD, R FIELD)

`RECORD` and `R FIELD` indicate records and record fields, respectively.

The `VALUE` field for a record is blank. The `ATTRIBUTES` field contains the size of the record in bytes, the number of bits (width) required for that record, and its default value.

The `VALUE` field for a record field contains its shift count. The `ATTRIBUTES` field contains the name of the record containing the field and the field's bit width.

## Registers (REG)

REG in the TYPE field indicates a register. The VALUE field contains the register name and the ATTRIBUTES field is blank.

## Segments (SEGMENT)

SEGMENT in the TYPE field indicates a code or data segment. The VALUE field is blank. The first entry in the ATTRIBUTES field is the segment size. The remaining attributes duplicate the attributes declared in the segment definition line, including the defaults.

## Stack Segments (STACK)

STACK in the TYPE field indicates a stack segment. The VALUE field is blank. The ATTRIBUTES field contains the segment size and information about the attributes, such as whether they are read-write (RW) or PUBLIC. The remaining attributes duplicate the attributes declared in the segment definition line, including the defaults.

## Structures and Structure Fields (STRUC, S FIELD)

STRUC in the TYPE field indicates a structure. The VALUE field is blank. The ATTRIBUTES field contains the structure size in bytes, and the number of its fields.

If a symbol is a structure field, its type appears in the TYPE field and SFIELD appears in the ATTRIBUTES field. The VALUE field contains the hexadecimal offset from the start of the structure in which the field was defined.

## Undefined Symbols (-----)

A symbol that was never defined, or was purged and then referenced without definition, is indicated by ----- in the TYPE field. The VALUE field is blank and the ATTRIBUTES field contains --UNDEFINED--.

## Variables (V BIT . . . V n)

The types for variables are V BIT, V BYTE, V WORD, V DWORD, V PWORD, V QWORD, VTBYTE, V STRUC, and V n (where n is the type value).

The VALUE field shows the variable's offset. The ATTRIBUTES field contains the segment name, if known, and PUBLIC or EXTRN, if appropriate. Variable names defined in an EQU statement can have indexing and segment override attributes. The override is displayed as the segment register name. Any indices are indicated by the index register name. If the variable is defined as an array, the item count appears in the ATTRIBUTES field as a decimal number in parentheses.

V ABS in the TYPE field indicates an external absolute number. The VALUE field contains a zero and the ATTRIBUTES field contains EXTRN.





This appendix begins with a description of the types of assembler errors and their error message formats. Following the descriptions is a numerical list of the assembler source file error and warning messages and their explanations.

## Fatal Errors

Fatal errors cause the assembler to stop processing the source file, display an error message, and return control to the operating system. There are three types of fatal errors: invocation control errors, I/O errors, and internal errors. These errors cause the assembler to stop processing the source module without producing an object module. The following sections explain the types of fatal errors and their message formats.

## Invocation Control Errors

Invocation control errors occur when controls or their parameters are specified incorrectly on the invocation line. The error messages have the following basic format:

```
ASM386 CONTROL ERROR
CONTROL: control
PARAMETER: parameter
DELIMITER: character
ERROR: description
ASM386 TERMINATED
```

The *parameter* and *delimiter* lines appear if you specify an incorrect delimiter or control parameter.

The error *descriptions* are the same as source file nonfatal errors. They are explained at the end of this appendix in numerical order.

## I/O Errors

I/O errors indicate problems in using external files or devices. I/O error messages have the following format:

```
ASM386 I/O ERROR
  FILENAME = filename
  ERROR = error number and description
ASM386 TERMINATED
```

Where:

*filename* is the name of the file containing the error.

*error number* is the operating system error number.

## Internal Errors

An assembler internal error indicates that an internal consistency check has failed. If an internal error occurs, contact RadiSys, following the instructions on the inside back cover of this manual. Please save the exact text of the error message, which has the following form:

```
*** ASM386 INTERNAL ERROR : description
```

## Nonfatal Errors and Warnings

The remaining errors are nonfatal and occur within the source file itself. When a nonfatal error occurs, the error line assembly is usually wrong; subsequent lines, however, can still be assembled correctly.

The basic nonfatal error message contains an error number, a source line number, and a brief description. No line number is given if the assembler detected the error before the first source line. The message appears in the print and errorprint files after the line on which the error was detected.

The following are the message formats:

```
*** ERROR n IN l, description
*** ERROR n IN l, type description
*** ERROR n IN l, (LINE m) description
```

Where:

*n* is a decimal number.

*l* is the number of the listing line in which the error occurred.

*type* is one of the following:

(PASS 2)	indicates an error in pass 2 of the assembler.
(MACRO)	indicates a macro error.
(CONTROL)	indicates an assembler control error.
(LINE <i>m</i> )	is the line number of an error.

See also: Assembler passes, Chapter 1

## Syntax Errors

A syntax error indicates that the program does not conform to the assembly language's grammar rules.

The syntax error message has this form:

```
*** -----/\
*** ERROR 1 IN l, SYNTAX ERROR
```

The assembler usually discards the remainder of the line following the syntax error. If the error occurs within a codemacro definition, the assembler exits definition mode, causing the ENDM statement to produce another syntax error, which is eliminated when the first error is corrected.

The pointer normally indicates the location of the syntax error. For example:

```
ASSUME ES
```

produces a syntax error after `ES`, indicating that the line is missing a colon followed by a segment name at the end. However, the assembler may not detect the error until one or more characters later. For example:

```
AAA DB 0
```

produces a syntax error at `DB` although `AAA`, already defined as an instruction (ASCII adjust for addition), is the actual error. The assembler interprets the line as an `AAA` instruction with `DB 0` as the operand field, and because the keyword `DB` is not a legal parameter, the assembler flags it as the error.

The assembler treats codemacro, register, and record names as unique syntactic entities. If you use these kinds of names improperly, you often receive a syntax error. For example:

```
ES EQU 7
```

is a syntax error because `ES` is a register name and is therefore syntactically distinct from an undefined symbol.

Syntax errors can occur for lines that by themselves are syntactically correct, but are misplaced within the program. For example, if the following statement is appropriately placed, it is syntactically correct:

```
FOO ENDS
```

However, if it were placed as follows:

```
DATA      SEGMENT
          :
          :
FOO      ENDS
```

it would produce an error, because a syntax error occurs if a `SEGMENT` or `PROC` statement does not have a corresponding `ENDS` or `ENDP` statement.

## Warnings

Warnings occur when the assembler has assembled a source line without producing an assembler error, but in a way that could later cause errors during object module processing or execution. The warning message format is basically the same as the nonfatal error message format:

```
*** WARNING #n IN l, description
```

## Macro Errors

When assembling source files, the assembler processes macros first if the `MACRO` control (the default) is in effect. Macro errors are errors detected during this macro pass. An example of a macro error is

```
UNDEFINED MACRO NAME
```

which indicates that the text following a metacharacter (`%` by default) is not a recognized user function name or built-in macro function.

Macro errors are followed by a trace of the macro call, which is a series of lines containing the names of the primary source file and currently nested include files, and every pending or active macro call.

## Control Errors

A control error occurs in a source file control line (or in the invocation line, as discussed earlier). One example is

```
UNKNOWN CONTROL
```

which indicates that a specified control is not legal.

# Source File Error and Warning Messages

The remainder of this appendix is a numerical list of the assembler source file error and warning messages and their explanations.

\*\*\* ERROR #1 SYNTAX ERROR

Your program does not conform to the assembly language's grammar rules.

\*\*\* ERROR #2 TOKEN TOO LONG

The maximum token length is 255 characters.

\*\*\* ERROR #3 ORDINAL NUMBER TOO LARGE

Some 64-bit integer values cannot be represented in packed-decimal form. The approximate range of 64-bit binary numbers is  $-1.8 \times 10^{19}$  to  $1.8 \times 10^{19}$ , where the range of values that can be represented by the packed-decimal format is  $-10^{18} - 1$  to  $10^{18} - 1$ .

\*\*\* ERROR #4 BAD ASM386 CHARACTER

The assembler found an illegal character in the input file. An unprintable ASCII character (which is shown as an up arrow) may cause this error. If the unprintable character is in a string or comment, the string or comment is terminated, and processing continues with the next character; a syntax error may occur.

A printable character that has no function in the assembly language can also cause this error. This often occurs when macro calls, beginning with the macro metacharacter, appear in a file that is assembled with the `NOMACRO` control.

\*\*\* ERROR #5 REAL NUMBER TOO LARGE

The hexadecimal real number specified does not fit the size of the defined variable.

See also: Ranges of variables, *ASM386 Assembly Language Reference*

\*\*\* ERROR #6 DECIMAL CONVERSION ERROR

A precision underflow or overflow occurred when converting decimal to extended precision real.

See also: Ranges of variables, *ASM386 Assembly Language Reference*

\*\*\* ERROR #7 ARITHMETIC OVERFLOW IN EXPRESSION OR LOCATION COUNTER

This error occurs when an answer to a calculation does not fit the corresponding storage (for example, not between -128 and 127 or 0 to 255). Such instances include:

- Expressions with large answers or intermediate values
- Division by zero
- Oversize constants

The error also occurs when the evaluation of the location counter gives a result greater than the maximum value (64K for USE16 segments or four gigabytes for USE32 segments).

For example, `X DW 80000001H DUP (0)` means duplicate 2G+1 times, a word whose content is 0. The length of a word is 2, therefore the location counter must be incremented by 2 x 80000001H or 4G+2. This is not a valid 32-bit number and error #7 is issued.

Certain floating-point values incorrectly elicit an arithmetic overflow message. These hexadecimal real values are:

**SINGLE PRECISION REALS (DD):**

07FFFFFFFFR, 07F800001R, 07F800000R, 0007FFFFFFFFR, 000000001R,  
000000000R, 080000000R, 080000001R, 0807FFFFFFFFR, 0FF800000R,  
0FF800001R, 0FFC00000R, 0FFFFFFFFR

**DOUBLE PRECISION REALS (DQ):**

07FF0000000000001R, 07FF0000000000000R, 0000FFFFFFFFFFFFFFFR,  
00000000000000001R, 00000000000000000R, 08000000000000000R,  
08000000000000001R, 0800FFFFFFFFFFFFFFFR, 0FFF0000000000000R,  
0FFF0000000000001R, 0FFF8000000000000R, 0FFFFFFFFFFFFFFFR

\*\*\* ERROR #8 STACK OVERFLOW; STATEMENT TOO COMPLEX

The assembly statement is too complex for the assembler to process. Simplify your statement.

\*\*\* ERROR #9 STACK OVERFLOW; STATEMENT TOO LONG

The assembly statement is too long for the assembler to process. Simplify your statement.

- \*\*\* ERROR #10 BAD OPERANDS FOR RELATIONAL OR SUBTRACTION OPERATION
- Subtraction and relational operations are legal only if the right side is an absolute number, or if both sides are relocatable. If both sides are relocatable, they must both be declared within the same segment, and neither can be external.
- \*\*\* ERROR #11 UNDEFINED SYMBOL; ZERO USED
- An undefined symbol has occurred in an expression. Zero is used in its place, which may cause other errors.
- \*\*\* ERROR #12 STORAGE INITIALIZATION EXPRESSION IS OF THE WRONG TYPE
- The only kinds of expressions allowed in initialization lists are variables, labels, strings, formals, and numbers. This error also occurs when the expression's value is too large for the allocated storage.
- \*\*\* ERROR #13 ABSOLUTE OPERAND REQUIRED IN THIS EXPRESSION
- Certain expression operators require their operands to be absolute numbers. These operators include unary minus, divide, multiply, AND, MOD, NEG, OR, SHL, SHR, XOR, LOW, HIGH, LOWW, HIGHW.
- \*\*\* ERROR #14 SIZE OF STACK SEGMENT HAS INCREASED PAST 64K
- A USE16 stack segment has been specified more than once using the STACKSEG directive with the same stack name. The stack sizes given for each specification are added together to form a total stack size for that particular stack segment. The latest specification has caused the total stack size to exceed 64K.
- \*\*\* ERROR #15 SIZE OF STACK SEGMENT HAS INCREASED PAST FOUR GIGABYTES
- A USE32 stack segment has been specified more than once using the STACKSEG directive with the same stack name. The stack sizes given for each specification are added together to form a total stack size for that particular stack segment. The latest specification has caused the total stack size to exceed 4 gigabytes.
- \*\*\* ERROR #16 SEGMENT USED TO INITIALIZE CS MUST BE TYPE EO OR ER
- The segment containing the label used to initialize the CS register in the END statement must be executable. Therefore, the segment must have an access-type of EO or ER.

\*\*\* ERROR #17 COMBINE-TYPE DOES NOT MATCH ORIGINAL SEGMENT DEFINITION

If more than one `SEGMENT-ENDS` pair exists for the same segment in the program, they must have the same combine-type. For example, you cannot specify the first one without a combine-type (`private`), and declare a subsequent one to be `PUBLIC`. Leaving the combine-type blank for subsequent `SEGMENT` declaratives in the same module is acceptable; the combine-type given in the first declarative is used.

\*\*\* ERROR #18 SEGMENT CANNOT BE TYPE EO

The segment used to initialize the `DS` register in the `END` statement, or the `DS` or `ES` register in the `ASSUME` statement cannot have access-type `EO`.

\*\*\* ERROR #19 SEGMENT USED TO INITIALIZE `SS` MUST BE TYPE RW

The segment used to initialize the `SS` register in the `END` or `ASSUME` statement must be writable, and therefore have access-type `RW`.

\*\*\* ERROR #20 SEGMENT ACCESS-TYPE TO RW

The segment has been declared to have a data part (`SEGMENT` directive) and a stack part (`STACKSEG` directive). Because the stack part is always `RW`, the data part must also be `RW`.

\*\*\* ERROR #21 --- FILE DOES NOT EXIST

In DOS systems, this message may be issued even though the file does exist. The PC/DOS Operating System is installed incorrectly. Re-install the Operating System and make sure that it is DOS V3.0 or later. DOS V3.0 or greater has a different `COMMAND.COM` file.

\*\*\* WARNING #21 `CS-(E)IP AND/OR SS-SP AND/OR DS NOT INITIALIZED; REQUIRED FOR MAIN MODULE`

The `END` statement has no `CS` and/or `SS` and/or `DS` register initialization. All three of these initializations are necessary for a main module.

\*\*\* ERROR #22 MISSING END OF SEGMENT STATEMENT

A segment definition must end with a statement in the form:

```
name ENDS
```

Where:

*name* is the segment name given in the corresponding `SEGMENT` directive.

\*\*\* ERROR #23 MISSING END OF MODULE STATEMENT

The `END` directive is required as the last statement in all the assembler modules.

\*\*\* ERROR #24 MISSING NAME STATEMENT; DEFAULT MODULE NAME USED

Every module must contain the `NAME` directive to include a name on the list file header and in the object module. If the `NAME` directive is omitted, the name "ANONYMOUS" is used.

\*\*\* ERROR #25 MISSING END OF STRUCTURE STATEMENT

A structure definition must end with a statement in the form:

*name* ENDS

Where:

*name* is the structure name given in the corresponding `STRUC` directive.

\*\*\* ERROR #26 MISSING END OF CODEMACRO STATEMENT

The definition of a codemacro must end with the `ENDM` statement.

\*\*\* ERROR #27 UNDEFINED SEGMENT IN INITIALIZATION

All segment references within an initialization must be to a defined segment.

\*\*\* ERROR #28 NO DEFINITION FOR PUBLIC SYMBOL

A public symbol must be defined within the module.

\*\*\* ERROR #29 ILLEGAL OPERAND TO THIS OPERATOR

The `THIS` operator accepts only a type specifier or a small-integer absolute number as an operand.

\*\*\* ERROR #30 IDENTIFIER MUST BE A LABEL FOR A CS-(E)IP INITIALIZATION

The identifier used in the `CS-IP` or `CS-EIP` initialization must be a label. Check the definition of the indicated identifier.

\*\*\* ERROR #31 SEGMENT WITH SAME NAME AS STACK MUST BE PUBLIC AND TYPE RW

The segment has been declared to have a data part (via the `SEGMENT` directive) and a stack part (via the `STACKSEG` directive). Because the stack part is always `PUBLIC` and has access-type `RW`, the data part must also be `PUBLIC` and `RW`.

\*\*\* ERROR #32 VARIABLES NOT ALLOWED IN REGISTER INITIALIZATION

Variables cannot be used to initialize the `DS` or `SS` segment registers in the `END` statement. Only segment names can initialize segment registers in this context. A label is required to initialize the `CS` segment registers.

\*\*\* ERROR #33 OPERANDS TO LOGICAL OPERATORS MUST BE ABSOLUTE NUMBERS

Other types of operands are not allowed.

\*\*\* ERROR #34 OPERAND TO BITOFFSET OPERATOR MUST BE A VARIABLE OR STRUCTURE FIELD

BITOFFSET allows you to convert variables or structure fields to numbers. If you receive this error message, you probably already have a number.

\*\*\* ERROR #35 NO DEFINITION FOR COMM SYMBOL

A COMM symbol must be defined within the module.

\*\*\* ERROR #36 OPERAND TO TYPE OPERATOR MUST BE A VARIABLE, STRUCTURE FIELD, OR LABEL

TYPE can only be used with a variable, structure field, or label. Any other parameter is illegal.

\*\*\* ERROR #37 OPERAND TO LENGTH OPERATOR MUST BE A VARIABLE OR STRUCTURE FIELD

LENGTH can be used only with a variable or a structure field. Any other parameter is illegal.

\*\*\* ERROR #38 OPERAND TO SIZE OPERATOR MUST BE A VARIABLE OR STRUCTURE FIELD

SIZE can be used only with a variable or a structure field. Any other parameter is illegal.

\*\*\* ERROR #39 OPERAND TO WIDTH OPERATOR MUST BE A RECORD

You cannot obtain the width of anything else.

\*\*\* ERROR #40 OPERAND TO MASK OPERATOR MUST BE A RECORD FIELD NAME

MASK of anything else has no meaning.

\*\*\* ERROR #41 OPERAND TO STACKSTART OPERATOR MUST BE A STACK SEGMENT

The operand to STACKSTART must be defined with the STACKSEG directive.

\*\*\* ERROR #42 OPERAND TO OFFSET OPERATOR MUST BE A VARIABLE OR LABEL

The OFFSET operator allows you to convert variables or labels to numbers. If you receive this error message, you probably already have a number.

\*\*\* ERROR #43 OPERANDS DO NOT MATCH THIS INSTRUCTION

This error usually indicates that the type of one of the operands is inappropriate for the instruction. For example, the following sequence generates this error:

```
VAR DT 0
PUSH VAR
```

Because VAR is a TBYTE variable, it cannot be pushed on the stack with PUSH.

\*\*\* ERROR #44 OPERAND NOT REACHABLE FROM SEGMENT REGISTERS

This error occurs when the `ASSUME` statement is used incorrectly. For every code segment reference to a variable that is not defined in the current segment, the segment in which that variable is defined must be assumed to be accessible from one of the segment registers. For most programs, a single `ASSUME` statement at the top of the program for segment registers `DS`, `ES`, `FS`, `GS`, and `SS` is sufficient.

```
*** ERROR #45 BAD SCALE FACTOR; MUST EVALUATE TO THE ORDINAL VALUE
1, 2, 4, OR 8
```

The only values allowed for index scaling are 1, 2, 4, or 8.

```
*** ERROR #46 PWORD IS A BAD SCALE FACTOR; MUST EVALUATE TO THE
ORDINAL VALUE
```

A `pword` is not allowed as an index scale value.

```
*** ERROR #47 TBYTE IS A BAD SCALE FACTOR; MUST EVALUATE TO THE
ORDINAL VALUE
```

A `tbyte` is not allowed as an index scale value.

```
*** ERROR #48 32-BIT AND 16-BIT ADDRESSING CANNOT BE COMBINED
```

The address expression has both 32-bit and 16-bit elements. For example:

```
MOV AX, [EAX BX]
```

is not legal.

```
*** ERROR #49 SYMBOL ALREADY DEFINED; CURRENT DEFINITION IGNORED
```

A symbol has an illegal multiple definition.

```
*** ERROR #50 ILLEGAL CIRCULAR EQU CHAIN
```

The following is an example of a circular chain of `EQU` statements:

```
VAR_1 EQU MYVAR
MYVAR EQU VAR_1
```

```
*** ERROR #51 EQU EXPRESSION CANNOT CONTAIN A FORWARD REFERENCE
```

You cannot equate to expressions containing forward references.

```
*** ERROR #52 BAD EQU EXPRESSION
```

An illegal expression occurred in an `EQU` statement. For example, the following statement causes this error:

```
VAR EQU [BX - SI]
```

\*\*\* ERROR #53 EQU FORWARD REFERENCE CAN ONLY BE A VARIABLE, LABEL, OR EQU SYMBOL

You can equate to simple forward-reference names, but not to an expression containing forward references.

\*\*\* ERROR #54 COMBINING BIT OFFSET AND BYTE DISPLACEMENT EXCEEDS MAXIMUM SEGMENT SIZE

The result from adding the bit offset and the byte displacement is greater than the 64K limit for USE16 segments or the 4 gigabytes allowed for USE32 segments. The following example shows this case:

```
BT VAR, 0FFFFH
```

where VAR is at offset 0FFFFH in a USE16 segment.

\*\*\* ERROR #55 STRING CONSTANT CANNOT EXCEED EIGHT CHARACTERS

A string constant used to initialize a dword can contain at most eight characters.

\*\*\* ERROR #56 RELATIVE DISPLACEMENT TOO LARGE FOR A USE16 SEGMENT

A relative displacement greater than 16K is not allowed in a USE16 segment. The target would not be reachable using a 16-bit relative displacement.

\*\*\* ERROR #57 RELATIVE DISPLACEMENT TOO LARGE FOR A USE32 SEGMENT

A relative displacement greater than 4 gigabytes is not allowed in a USE32 segment. The target would not be reachable using a 32-bit relative displacement.

\*\*\* ERROR #58 ADDITION OF DISPLACEMENT CAUSED OVERFLOW

The result of the displacement evaluation is either greater than 64K in a USE16 segment, or greater than 4 gigabytes in a USE32 segment.

\*\*\* ERROR #59 IMMEDIATE DWORD OVERFLOW

An expression has a value that is out of range for storage in a dword.

\*\*\* ERROR #60 IMMEDIATE WORD OVERFLOW

An expression has a value that is out of range for storage in a word.

\*\*\* ERROR #61 DISPLACEMENT TOO LARGE FOR A USE16 SEGMENT

The displacement computed by the assembler is greater than 64K.

\*\*\* ERROR #62 DISPLACEMENT TOO LARGE FOR A USE32 SEGMENT

The displacement computed by the assembler is greater than 4 gigabytes.

\*\*\* ERROR #63 INVALID SYMBOL TYPE

The symbol type does not match the required operand type for the given instruction. For example, if F1 is a structure field, then the following statement is an invalid specification:

```
PUSH F1
```

\*\*\* ERROR #64 LABEL DECLARED NEAR IS NOT IN THE CURRENT SEGMENT

A label referenced in the current segment is not local to that segment; it was declared in another segment. Change the label type to FAR.

\*\*\* ERROR #65 TWO REPEAT PREFIXES ARE ILLEGAL

Delete one REPEAT prefix.

\*\*\* ERROR #66 TWO LOCK PREFIXES ARE ILLEGAL

Delete one LOCK prefix.

\*\*\* ERROR #67 SEGMENT SIZE EXCEEDED

The location counter has become greater than 64K for a USE16 segment or greater than 4 gigabytes for a USE32 segment. Split the segment into smaller segments.

\*\*\* ERROR #68 PASS TWO INSTRUCTION SIZE EXCEEDED PASS ONE ESTIMATE

This error occurs when the instruction contains a forward reference and the assembler overestimates the amount of code the forward reference causes the instruction to generate. Overestimating usually occurs when:

- The forward reference is a variable that requires a segment override prefix. For forward references, explicitly code the override if the operand is in a different segment:

```
MOV CX, ES:FWD_REF
```

- Otherwise, the assembler assumes that it is not needed.
- The forward reference is a FAR label. Explicitly provide the type in this case:

```
JMP FAR PTR FWD_LABEL
```

Otherwise, the assembler assumes NEAR.

- SHORT is indicated, or an instruction is used that takes only SHORT displacements. Change the code so that it does not use a SHORT jump.

\*\*\* ERROR #69 BAD OPERAND TO MONADIC INSTRUCTION

Monadic means an instruction with one operand. The type of the operand does not match the type required for this instruction.

\*\*\* ERROR #70 CURRENT SEGMENT NOT EXECUTABLE

You cannot include instructions in a non-executable segment. Change the segment attribute in the `SEGMENT` declarative.

\*\*\* ERROR #71 FIRST OPERAND IS ILLEGAL

The type of the first operand does not match the type required for this instruction.

\*\*\* ERROR #72 FIRST OPERAND CONTAINS AN UNDEFINED SYMBOL

An undefined symbol was included in the expression used as the first operand for this instruction.

\*\*\* ERROR #73 SECOND OPERAND IS ILLEGAL

The type of the second operand does not match the type required for this instruction.

\*\*\* ERROR #74 SECOND OPERAND CONTAINS AN UNDEFINED SYMBOL

An undefined symbol was included in the expression used as the second operand for this instruction.

\*\*\* ERROR #75 ILLEGAL OPERAND COMBINATION

The type of one of the operands to the instruction does not match the type required for the other operands. For example, the following sequence generates this error:

```
VAR DW 0
MOV BL, VAR
```

Because `VAR` is a `WORD` variable, it cannot be moved into the register `BL`.

\*\*\* ERROR #76 IMMEDIATE EXCEEDS 31; ONLY THE LOWER FIVE BITS WILL BE USED

The number or expression used as an immediate value is greater than 31, which is illegal in this context.

\*\*\* ERROR #77 IMMEDIATE EXCEEDS LIMITS IN THIS CONTEXT

The number or expression used as an immediate value is greater than the legal value for this context.

\*\*\* ERROR #79 SECOND OPERAND MUST BE CL

The second operand for this instruction cannot be anything other than the 8-bit general register `CL`.

\*\*\* ERROR #80 FIRST OPERAND MUST BE DX OR EDX

The first operand to this instruction cannot be anything other than the `DX` or the `EDX` register.

- \*\*\* ERROR #81 THIS INSTRUCTION REQUIRES AT LEAST ONE OPERAND  
This instruction must be specified with one or more operands. Some instructions such as RET accept one or no operands; others, such as ADD, require two operands.
- \*\*\* ERROR #82 THIS INSTRUCTION DOES NOT ACCEPT ONE OPERAND  
Check the description of this instruction in the *ASM386 Assembly Language Reference*.
- \*\*\* ERROR #83 THIS INSTRUCTION DOES NOT ACCEPT TWO OPERANDS  
Check the description of this instruction in the *ASM386 Assembly Language Reference*.
- \*\*\* ERROR #84 THIS INSTRUCTION DOES NOT ACCEPT THREE OPERANDS  
Check the description of the instruction in the *ASM386 Assembly Language Reference*.
- \*\*\* ERROR #85 UNDEFINED SYMBOL  
The symbol used has not been defined. Add a declaration for the symbol or check for a misspelling of the symbol.
- \*\*\* ERROR #86 SECOND OPERAND MUST BE AX  
The second operand for this instruction cannot be anything other than the AX register.
- \*\*\* ERROR #87 SECOND OPERAND MUST BE EAX  
The second operand for this instruction cannot be anything other than the EAX register.
- \*\*\* ERROR #88 THIRD OPERAND IS ILLEGAL  
The third operand for this instruction is of an incorrect type.
- \*\*\* ERROR #89 THIRD OPERAND CONTAINS AN UNDEFINED SYMBOL  
An undefined symbol is included in the expression used as the third operand for this instruction.
- \*\*\* ERROR #96 STATEMENT NOT ALLOWED OUTSIDE SEGMENT BOUNDARIES  
The statement must be included within a SEGMENT/ENDS pair. Otherwise, it is ignored by the assembler.
- \*\*\* ERROR #97 EIGHT-BIT REGISTER IS ILLEGAL IN A REGISTER EXPRESSION  
8-bit registers are not allowed in a register expression.

\*\*\* ERROR #98 ILLEGAL REGISTER EXPRESSION

The register expression contains some illegal operations. For example, the following is an illegal register expression:

```
PUSH WORD PTR DS:[BX] + AX
```

\*\*\* ERROR #99 NO MORE THAN TWO REGISTERS ALLOWED IN A REGISTER EXPRESSION

Up to two registers can be specified in a register expression.

\*\*\* ERROR #100 ILLEGAL SYMBOLIC REFERENCE IN A REGISTER EXPRESSION

You cannot mix a symbolic reference within a register expression.

\*\*\* ERROR #101 ILLEGAL OPERATION ON SYMBOLIC REFERENCE WITHIN SQUARE BRACKETS

Symbols cannot be specified within bracketed register expressions. For example, the following is an illegal operation:

```
PUSH WORD PTR[EBX + VAR]
```

\*\*\* ERROR #102 SCALED INDEX REGISTER MUST BE IN SQUARE BRACKETS

Index registers used with scale specifications must be within square brackets.

\*\*\* ERROR #103 OPERAND TO DOT OPERATOR MUST BE A STRUCTURE FIELD

The dot operator used outside a codemacro is legal only if the left operand is an address expression and the right operand is a structure field.

\*\*\* ERROR #104 ILLEGAL FLOATING POINT STACK ELEMENT VALUE; ZERO USED

Stack elements can be specified only as ST or ST(*i*), where *i* is in the range of 0 to 7.

\*\*\* ERROR #105 REGISTER EXPRESSION ILLEGAL OUTSIDE OF SQUARE BRACKETS

A register can undergo arithmetic inside square brackets; the operations are performed on the memory address represented by the bracketed expression. The arithmetic makes no sense outside the brackets, and is flagged. For example, the following is illegal:

```
JMP BX + 3
```

but the following is legal:

```
JMP [BX + 3]
```

```
JMP [BX] + 3
```

- \*\*\* ERROR #106 ESP CANNOT BE USED AS AN INDEX REGISTER
- Any general register except ESP can be used as an index register.
- \*\*\* ERROR #107 EXPRESSION CANNOT BE USED AS A FLOATING POINT STACK ELEMENT; ZERO USED
- The expression cannot be used as a stack element index.
- \*\*\* ERROR #108 ILLEGAL OPERAND TO SEG OPERATOR
- The operand to SEG as it appears in an ASSUME statement must be a variable or a label (i.e., it must have a segment associated with it).
- \*\*\* ERROR #109 ILLEGAL OPERAND SEGMENT ASSUMPTION TO OTHER THAN ES
- The destination operand of a string instruction must be accessible through the ES register.
- \*\*\* ERROR #110 DEFAULT ES SEGMENT REGISTER CANNOT BE OVERRIDDEN
- The string imperatives that involve the EDI register do not allow for an override of the default ES register; thus, the assembler requires the operand to the instruction to be accessible from the ES register.
- \*\*\* WARNING #111 USE OF THE EVEN DIRECTIVE IN THIS CONTEXT DISABLES CODE OPTIMIZATION
- The assembler does not attempt to optimize instructions containing forward references after specification of the EVEN directive.
- \*\*\* ERROR #112 ILLEGAL INDEX REGISTER USED IN SECOND OPERAND; MUST BE EDI OR DI
- Only the general registers EDI or DI are allowed as index registers for the second operand of this instruction.
- \*\*\* ERROR #113 ILLEGAL INDEX REGISTER USED IN SECOND OPERAND; MUST BE ESI OR SI
- Only the general registers ESI or SI are allowed as index registers for the second operand of this instruction.
- \*\*\* ERROR #114 ILLEGAL INDEX REGISTER USED IN FIRST OPERAND; MUST BE ESI OR SI
- Only the general registers ESI or SI are allowed as index registers for the first operand of this instruction.
- \*\*\* ERROR #115 ILLEGAL INDEX REGISTER USED IN FIRST OPERAND; MUST BE EDI OR DI
- Only the general registers EDI or DI are allowed as index registers for the first operand of this instruction.

\*\*\* ERROR #116 ILLEGAL INDEX REGISTER USED; MUST BE EDI OR DI  
Only the general registers EDI or DI are allowed as index registers in this context.

\*\*\* ERROR #117 ILLEGAL INDEX REGISTER USED; MUST BE ESI OR SI  
Only the general registers ESI or SI are allowed as index registers in this context.

\*\*\* ERROR #118 NEAR USE16 CALL OR JUMP ILLEGAL IN A USE32 CONTEXT  
In a USE32 segment, you cannot specify JMP [AX] because a NEAR USE16 jump uses only the lower 16 bits of EIP.

\*\*\* ERROR #119 EXCEEDED NUMBER OF OPERANDS ALLOWED FOR CODEMACROS  
The maximum number of operands for a codemacro is 15.

\*\*\* ERROR #120 NO IMPERATIVE OR CODEMACRO DEFINED WITH THIS NAME  
You have coded an undefined instruction.

\*\*\* ERROR #121 OPERANDS DO NOT MATCH ANY IMPERATIVE OR CODEMACRO  
The number of operands specified for the instruction does not match the number required for any known imperatives or codemacros.

\*\*\* ERROR #122 INSIDE A CODEMACRO, THE OPERAND TO THE DOT OPERATOR MUST BE A RECORD FIELD  
You have used the DOT operator with a variable of a type other than RECORD.

\*\*\* ERROR #123 FORWARD REFERENCE INSIDE A CODEMACRO IS NOT ALLOWED  
Forward references cannot be included within codemacros.

\*\*\* ERROR #124 CANNOT SHIFT A RELOCATABLE VALUE  
This error results when a relocatable value is passed as an operand to an instruction which shifts the operand. Shifting a relocatable value is not allowed.

\*\*\* ERROR #125 NUMBER OF BYTES GENERATED BY A CODEMACRO IS LIMITED TO 255  
The codemacro is too long; the maximum is 255 bytes.

\*\*\* ERROR #126 RELATIVE DISPLACEMENT WILL NOT FIT IN A BYTE  
This instruction expects a relative displacement within the range of -128 to +127.

\*\*\* ERROR #127 RELATIVE DISPLACEMENT WILL NOT FIT IN A WORD  
This instruction expects a relative displacement within the range of -32768 to +32767.

\*\*\* ERROR #128 RELATIVE DISPLACEMENT WILL NOT FIT IN A DWORD  
This instruction expects a relative displacement within the range of  $-2^{31}$  and  $+2^{31}-1$ .

\*\*\* ERROR #129 ILLEGAL OPERAND SEGMENT ASSUMPTION TO OTHER THAN S

\*\*\* ERROR #130 ILLEGAL OPERAND SEGMENT ASSUMPTION TO OTHER THAN DS

\*\*\* ERROR #131 ILLEGAL OPERAND SEGMENT ASSUMPTION TO OTHER THAN GS  
\*\*\* ERROR #132 ILLEGAL OPERAND SEGMENT ASSUMPTION TO OTHER THAN FS  
\*\*\* ERROR #133 ILLEGAL OPERAND SEGMENT ASSUMPTION TO OTHER THAN SS

For errors #129-133, the assembler requires that the operand for the instruction be reachable through the register indicated in the error message. These errors are generated when conditions specified in a user-defined codemacro using the NOSEGFIX statement have been violated.

\*\*\* ERROR #134 INSTRUCTION WAS PURGED

A purged symbol remains undefined until it is redefined.

\*\*\* ERROR #135 ILLEGAL OPERANDS INSIDE OF SQUARE BRACKETS

The only kind of expression allowed in square brackets is an expression involving registers and/or numbers. Address expressions and other constructs (e.g., record names) are not allowed.

\*\*\* ERROR #136 CANNOT ADD TWO RELOCATABLE NUMBERS

Only absolute numbers can be added.

\*\*\* ERROR #137 CANNOT SUBTRACT TWO RELOCATABLE NUMBERS IN DIFFERENT SEGMENTS

Two relocatable numbers can be subtracted only if they have been defined in the current module and in the same segment.

\*\*\* ERROR #138 CANNOT HAVE TWO INDEX REGISTERS IN A REGISTER EXPRESSION

Two-register expressions are legal only with one base register and one index register (and an optional displacement).

\*\*\* ERROR #139 CANNOT HAVE TWO BASE REGISTERS IN A REGISTER EXPRESSION

Two-register expressions are legal only with one base register and one index register (and an optional displacement).

\*\*\* WARNING #140 ILLEGAL USE OF THE CS REGISTER IN AN ASSUME

Unlike ASM86, the assembler automatically assumes that the selector of the current segment is in the CS register. CS is allowed in the ASSUME statement only if followed by NOTHING.

\*\*\* ERROR #141 N287 CONTROL SPECIFIED: 80387 INSTRUCTION IS ILLEGAL

When the N287 primary control is specified, any source code lines that contain Intel387 floating-point coprocessor instructions, not supported on the Intel287 coprocessor, are flagged as errors.

\*\*\* ERROR #142 INVALID OPERAND TO THE SHORT OPERATOR

The short operator cannot be used in address expressions which represent memory references. The short operator is used in LABEL expressions to indicate that jump is going to be (+127 bytes to -128 bytes) from the end of the current instruction.

\*\*\* ERROR #143 SEGMENT OVERRIDE NOT VALID IN A LABEL EXPRESSION

A segment override cannot be used in a label expression where the label type is NEAR or FAR. A segment override is used in an operand which represents a reference to memory.

\*\*\* ERROR #144 OPERAND TO LOW MUST BE A NUMBER OR ABS EXTRN

The LOW operator requires as an operand a constant expression that evaluates to a 16-bit number. Other types of operands (e.g., variables, labels, segment names, structure names, or record names) are not allowed.

\*\*\* ERROR #145 CANNOT USE SEGMENT OVERRIDE WITH A REGISTER

Segment override may only be used with a variable name, a label that is not of type NEAR or FAR, or an address expression.

\*\*\* WARNING #146 MORE THAN ONE FORWARD REFERENCE SYMBOL IN AN EXPRESSION

More than one reference in an expression has been made to symbols declared after the expression. Declare the symbol before the reference is made.

\*\*\* ERROR #200 80376 DOES NOT SUPPORT USE16 CODE OR STACK SEGMENTS

When the MOD376 control is specified, a USE16 segment directive cannot be used for a code or stack segment in the input file. Nor can a USE16 keyword be used in an EXTRN directive of type NEAR or FAR. USE16 data segments may be included in the input file. The assembler continues processing after detecting this error, but the object file will be invalid.

\*\*\* ERROR #201 80376 PHYSICAL ADDRESS SIZE EXCEEDED

The 376 processor has a 24-bit address bus. Thus, a segment must be no larger than 16 megabytes. When the MOD376 control is used, the assembler detects any segments that are too large and issues this error. The assembler continues processing, but the segment wraps to low memory, possibly overwriting segments that are in low memory.

- \*\*\* ERROR #202 RELOCATABLE CONSTANT EXPRESSIONS NOT ALLOWED
- The instruction or operator requires an expression that takes only absolute constants as a value.
- \*\*\* ERROR #203 VALUE LARGER THAN 256 BYTES NOT ALLOWED
- The instruction or operator requires an expression that evaluates to a number in the range of 1 to 256.
- \*\*\* ERROR #204 TEST REGISTER IS NOT VALID UNLESS MOD486 IS SPECIFIED
- The test registers TR3, TR4, and TR5 are only valid when the MOD486 control is specified.
- \*\*\* ERROR #205 INSTRUCTION IS NOT VALID UNLESS MOD486 IS SPECIFIED
- The instructions BSWAP, CMPXCHG, INVD, INVLPG, WBINVD, and XADD are only valid when the MOD486 control is specified.
- \*\*\* WARNING #206 NO SOURCE DEBUG INFORMATION FOR CODE SEGMENT
- There should only be one code segment in a module when the DEBUG control is specified. Source debug information is only generated for one code segment per module.
- \*\*\* ERROR #207 LOCK PREFIX IS NOT VALID WITH THIS INSTRUCTION
- The LOCK prefix is only valid with the memory forms of the following instructions: ADD, ADC, AND, BT, BTC, BTR, BTS, CMPXCHG, DEC, INC, NEG, NOT, OR, SBB, SUB, XADD, XCHG, XOR.
- \*\*\* ERROR #300 BINARY ORDINAL REQUIRED IN A DBIT; ZERO USED
- For a DBIT initialization, the values must be specified in binary format.
- \*\*\* ERROR #301 SYMBOL ALREADY DEFINED; THIS DEFINITION IGNORED
- This error message appears when a symbol is given an illegal multiple definition.
- \*\*\* ERROR #302 STORAGE INITIALIZATIONS NOT ALLOWED OUTSIDE OF USER-DEFINED SEGMENT
- All storage initializations (DBIT, DB, DW, DD, DP, DQ, DT, structure allocation, and record allocation) must appear within a user-defined segment (a SEGMENT/ENDS pair) or a codemacro definition.

\*\*\* ERROR #303 CANNOT HAVE A VARIABLE OR A LABEL IN A DBIT, DB, DQ, OR DT; ZERO USED

The variable or label used has the wrong type for the context. Although conversion to the offset number automatically occurs for variables of type DW, DD, and DP, it does not occur for those of type DBIT, DB, DQ, or DT. You must explicitly provide the OFFSET operator and be sure that the resulting number is absolute. In the case of a DB variable, the resulting number must also be small enough to fit in a byte.

\*\*\* ERROR #304 EXTERNAL NOT ALLOWED FOR INITIALIZATION

Because the value of the external symbol cannot be known at assembly-time, the initialization cannot be completed.

\*\*\* ERROR #305 MISMATCHED LABEL ON ENDS

ENDS requires a label that matches the corresponding SEGMENT or STRUCTURE declarative. If this error occurs, one of several things could be wrong. You could have a typographical error, a missing ENDS for a nested segment, or an error in the corresponding SEGMENT or STRUCTURE statement, in which case, this error is eliminated when the other is fixed.

\*\*\* ERROR #306 IDENTIFIER IS NOT A STRUCTURE OR RECORD NAME

In this form of data initialization, only structures or records are allowed.

\*\*\* ERROR #307 UNDEFINED STRUCTURE OR RECORD IDENTIFIER

You probably used the DOT operator with a structure or record whose name has not yet been defined. Alternately, you could have tried to initialize an undefined structure or record.

\*\*\* ERROR #308 TOO MANY OVERRIDING INITIALIZATIONS

When using a structure to allocate and initialize storage, the number of overriding expressions between angle brackets exceeded the number of fields in the structure. All extra values at the right end of the list are ignored. For example:

```
S STRUC
a DB 0
b DB 3
c DW 999H
S ENDS
foo S<1,4,0AAAH ; This is correct.
baz S<2,5,0BBBH,93> ; This is incorrect. It has
; four overriding values and
; only three fields.
abc S<, , , 88> ; This is also bad.
; Although only one value
; appears, the commas force
; it into the fourth
; position --- but
; the structure has no
; fourth field.
```

\*\*\* ERROR #309 STRUCTURE FIELD CANNOT BE OVERRIDDEN

Only structure fields initialized with a single expression, a single question mark, or a single string can be overridden.

\*\*\* ERROR #310 OVERRIDING STRING TOO LARGE FOR FIELD

If a structure field is initialized with a single string, the field can be overridden with a string that is less than or equal to it in length. If the overriding string is too long, it is truncated so that it fits into the field. (If it is too short, it is padded by the necessary last characters from the initializing string.)

\*\*\* ERROR #311 ILLEGAL USE OF STRUCTURE NAME

A structure name can appear as a storage initialization operator, as an operand of the size operator, or as a type in an EXTRN or LABEL statement. Any other use of a structure name is illegal.

\*\*\* ERROR #312 RELOCATABLE VALUE DOES NOT FIT IN ONE BYTE

Relocatable numbers cannot be operands for the DB directive.

\*\*\* ERROR #313 CANNOT USE A RELOCATABLE NUMBER FOR THIS INITIALIZATION

Relocatable numbers cannot be used in this initialization because it is impossible to determine at assembly-time how to sign-extend the number into the high-order bytes.

\*\*\* ERROR #314 STRING LONGER THAN FIELD SIZE ALLOWED ONLY IN DB

All strings outside the DB context are treated as absolute numbers; therefore, strings longer than the field size are overflow quantities.

\*\*\* ERROR #315 IDENTIFIER MUST BE A LABEL OR AN EQUATE

In this context, only a label or equate is allowed.

\*\*\* ERROR #316 CANNOT HAVE NESTED STRUCTURE DEFINITIONS

Structures cannot be nested.

\*\*\* ERROR #317 CANNOT USE A REAL NUMBER FOR DB, DW, OR DP INITIALIZATION

The DB, DW, and DP data initialization directives do not accept real numbers as operands.

\*\*\* ERROR #318 CANNOT USE A NEGATIVE DUP FACTOR; ONE USED

The repetition count of a DUP directive must be a positive number, greater than zero. The value 1 is used if the specified value is a negative number.

\*\*\* ERROR #320 DUP COUNT MUST BE GREATER THAN ZERO; ONE USED

The repetition count of a DUP directive must be a positive number, greater than zero. The value 1 is used if the specified value is zero.

\*\*\* ERROR #350 WORDCOUNT MAY ONLY BE USED WITH FAR PROCEDURES; IGNORED

A wordcount has meaning only for FAR procedures and therefore cannot be specified for NEAR procedures.

\*\*\* ERROR #351 WORDCOUNT MAY NOT BE GREATER THAN 31; IGNORED

If the specified wordcount is greater than 31, it is ignored. The procedure is considered to have a wordcount of 0.

\*\*\* ERROR #352 DOES NOT MATCH CURRENT PROC NAME IDENTIFIER

ENDP requires a label that matches the corresponding PROC declarative. One of several things could be wrong: a typographical error, a missing ENDP for a nested procedure, or an error in the corresponding PROC line, in which case this error is eliminated when the other is fixed.

\*\*\* ERROR #353 CANNOT HAVE MORE THAN ONE NAME DECLARATIVE

The first NAME declarative is honored and this one is ignored.

\*\*\* ERROR #354 SEGMENT CONTENTS DO NOT AGREE WITH ACCESS-TYPE

Either the segment contains executable code and has an access-type of RO or RW, or the segment contains data and has an access-type of EO.

\*\*\* ERROR #355 ACCESS-TYPE SET ACCORDING TO SEGMENT CONTENTS

After a `SEGMENT` declarative is processed, the assembler keeps track of whether code and/or data is contained in the segment. If the segment's access-type has not been set by the time the first `ENDS` is encountered, the information about the segment's contents is used to set the access-type.

\*\*\* ERROR #356 MISSING END OF PROCEDURE STATEMENT

A labelled `ENDP` statement was expected. You probably have specified an `ENDS` (end of segment) or an `END` (end of module) statement before closing the procedure definition.

\*\*\* ERROR #357 CODEMACRO NAME WAS PREVIOUSLY DEFINED AS A NON-CODEMACRO

Having non-codemacro definitions of a codemacro identifier is illegal. If a codemacro name has already been defined as something other than a codemacro, however, all definitions of the symbol must be codemacro definitions. If the symbol has been defined as anything else, it cannot be redefined as a codemacro unless it is first purged.

\*\*\* ERROR #358 TWO CODEMACRO FORMALS HAVE THE SAME NAME

All formals must have different names within a given codemacro definition.

\*\*\* ERROR #359 CANNOT HAVE MORE THAN 15 FORMAL PARAMETERS

This limitation is imposed by the internal codemacro coding formats.

\*\*\* ERROR #360 ILLEGAL SPECIFIER/MODIFIER FOR A CODEMACRO FORMAL

The only specifier letters allowed are A, C, D, E, F, M, R, S, T, and X. The only modifier letters allowed are B, BIT, D, DN, P, Q, T, and W (or none may be specified).

\*\*\* ERROR #361 SECOND PARAMETER MUST BE A FORMAL

The `MODRM` statement requires that the second parameter must be a formal parameter in the required format for this codemacro. For example, the following is in error:

```
CODEMACRO USR_MODRM FORMAL1:X
MODRM 0,0
ENDM
```

See also: Codemacro reference, *ASM386 Language Reference*

See Section 9.2 of the for details.

- \*\*\* ERROR #362 ILLEGAL NESTED CODEMACRO DEFINITIONS
- Nested codemacro definitions are not allowed.
- \*\*\* ERROR #363 ILLEGAL CODEMACRO SPECIFIER RANGE VALUE
- Range checking for codemacro matching is done only for parameters that are numbers or registers.
- \*\*\* ERROR #364 FORMAL PARAMETER EXPECTED BUT NOT SEEN
- In certain contexts in codemacros (i.e., RELB, RELW, SEGFIX, NOSEGFIX, and MODRM), the only construct allowed is a formal parameter. If the assembler encounters something other than a formal parameter, this error message appears.
- \*\*\* ERROR #365 STATEMENT MAY NOT APPEAR OUTSIDE A CODEMACRO DEFINITION
- The directive used (RELB, WARNING, etc.) can be specified only within a macro definition.
- \*\*\* ERROR #366 CODEMACRO NAME MUST BE AN IDENTIFIER
- A codemacro name must follow the same rules as any other assembler identifier. For example, it cannot begin with a digit.
- \*\*\* ERROR #367 FIRST PARAMETER MUST BE A FORMAL OR A NUMBER
- MODRM requires the first parameter to be the name of a formal parameter or an absolute number. For example, in the following, the first parameter AX to the MODRM statement is illegal:
- ```
CODEMACRO USER-MODRM FORMAL1:X
MODRM AX, FORMAL1
ENDM
```
- \*\*\* ERROR #368 PARAMETER MUST BE A FORMAL WITH AN E, M, OR X SPECIFIER
- This message signals an incompatibility between the type of a formal parameter and its usage.
- \*\*\* ERROR #369 SECOND PARAMETER MUST BE A FORMAL WITH AN M OR X SPECIFIER
- This message signals an incompatibility between the type of a formal parameter and its usage.
- \*\*\* ERROR #370 FIRST PARAMETER MUST BE A SEGMENT REGISTER
- NOSEGFIX requires the first parameter to be a segment register.

\*\*\* ERROR #371 PARAMETER MUST BE A FORMAL WITH CB, CW, CD, OR CDN SPECIFIER

A relative displacement statement in a codemacro definition requires the parameter to be a formal parameter list with the corresponding specifiers.

\*\*\* ERROR #372 FORMAL PARAMETER HAS ILLEGAL SPECIFIER TYPE

Specifiers can have only certain types. For example, a PREFIX67 statement could not use a formal with an A specifier.

\*\*\* ERROR #373 PARAMETER MUST BE A FORMAL

The parameter to this codemacro statement must be a formal. For example:

```
PREFIX67 0
```

is illegal.

\*\*\* ERROR #374 ACTUAL PARAMETER HAS ILLEGAL TYPE

The type of the actual parameter does not match that of the formal definition.

\*\*\* ERROR #375 NEGATIVE NUMBER NOT ALLOWED IN THIS CONTEXT

Negative numbers are not allowed in certain contexts, such as STACKSEG declaratives and DUP counts.

\*\*\* ERROR #376 MEMORY REFERENCE CANNOT BE REACHED WITH GIVEN SEGMENT REGISTER

The code is probably missing an ASSUME statement, so that the assembler cannot determine the segment base.

\*\*\* ERROR #377 SEGMENT CONTAINS PRIVILEGED INSTRUCTION(S)

The assembler has encountered one or more privileged instructions in the segment. There are two types of privileged instructions: instructions that can be executed only at privilege level 0, and instructions whose execution is restricted to IOPL level or more trusted.

The instructions that can be executed only at level 0 are LGDT, LLDT, LIDT, LTR, LMSW, CLTS, and HLT. The instructions whose execution is restricted to IOPL level or more trusted are INSB, INSW, OUTSB, INS, OUTS, IN, OUT, CLI, and STI.

Additional instructions that can be executed only at level 0 include MOV to or from CR0, CR2, CR3, DR0-3, DR6, DR7, TR3, TR4, TR5, TR6, and TR7.

The lowest privilege level that can execute these instructions is indicated by the I/O privilege level value in the flag register.

\*\*\* ERROR #378 ILLEGAL COMM VARIABLE TYPE

Only variables or labels can be declared as COMM and they cannot be initialized.

- \*\*\* ERROR #379 CANNOT PURGE PUBLIC OR EXTRN VARIABLE  
PUBLIC or EXTRN symbols cannot be purged.
- \*\*\* ERROR #380 CANNOT PURGE UNDEFINED SYMBOL  
The symbol you attempted to purge is undefined. (It may already have been purged.)
- \*\*\* ERROR #381 CANNOT LIST MORE THAN 255 EXTERNALS IN A SINGLE STATEMENT  
A single assembler statement may not contain more than 255 symbols declared to be EXTRN.
- \*\*\* ERROR #383 SEGMENT ACCESS-TYPE HAS BEEN CHANGED  
This message is a reminder that you have reopened a segment with a different access-type, which is legal as long as the access-types are compatible.
- \*\*\* ERROR #384 SEGMENT REOPENED WITH CONFLICTING ACCESS OR USE ATTRIBUTE  
The compatible sets of access-types are RO and RW, with a resulting type of RW, or any combination of RO, EO, and ER with a resulting type of ER. The USE attribute of a segment cannot be changed.
- \*\*\* ERROR #385 SYSTEM ERROR CAUSED BY ACCESS TO OBJECT MODULE  
An error occurred while the object module was being output. It could be an internal error or an I/O error.
- \*\*\* ERROR #500 UNDEFINED MACRO NAME  
The text following a metacharacter (%) is not a recognized user macro name or built-in macro function. The reference is ignored and processing continues with the character following the name.
- \*\*\* ERROR #501 ILLEGAL EXIT MACRO  
The built-in macro function EXIT is not valid in this context. The call has been ignored. A call to EXIT must allow an exit through a user function or the WHILE or REPEAT built-in functions.
- \*\*\* ERROR #502 FATAL SYSTEM ERROR  
The macro processor discovered a loss of hardware and/or software integrity. Contact RadiSys, following the instructions on the inside back cover of this manual.
- \*\*\* ERROR #503 ILLEGAL EXPRESSION  
A numeric expression was required as a parameter to one of the built-in macro functions. The function call has been terminated and processing continued with the character following the illegal expression.

\*\*\* ERROR #504 MISSING "FI"  
 The IF built-in function did not end with FI.

\*\*\* ERROR #505 MISSING "THEN"  
 A call to the IF macro function requires a THEN statement following the IF conditional expression clause. The call to IF has been aborted and processing continued at the point in the string at which the error was discovered.

\*\*\* ERROR #506 ILLEGAL ATTEMPT TO REDEFINE A MACRO  
 You cannot redefine a built-in macro function or parameter name. A user-defined macro cannot be redefined inside an expansion of itself.

\*\*\* ERROR #507 MISSING IDENTIFIER IN DEFINE PATTERN  
 In a DEFINE statement, the occurrence of an at sign (@) indicates that an identifier type delimiter follows. No such delimiter existed and the DEFINE was aborted. Scanning continued from the point at which the error was detected.

\*\*\* ERROR #508 MISSING BALANCED STRING  
 The macro processor expected a balanced-text string. The macro call was aborted and scanning continued from the point at which the error was detected.

\*\*\* ERROR #509 MISSING LIST ITEM  
 In a built-in macro function, a parenthesized parameter is missing. The call was aborted and scanning continued from the point at which the error was detected.

\*\*\* ERROR #510 MISSING DELIMITER  
 A required delimiter was not present. The macro call was aborted and scanning continued from the point at which the error was detected. This error occurs only if a user macro was defined with a call-pattern containing two adjacent delimiters. If the first delimiter was scanned but was not immediately followed by the second, this error occurs.

\*\*\* ERROR #511 PREMATURE EOF  
 The end of the input file occurred while the call to the macro was being scanned. This usually occurs when a delimiter to a macro call was omitted, causing the macro processor to scan to the end of the file searching for the missing delimiter. This error can occur even if the closing delimiter of a macro call was given (and any preceding delimiters were not given) because the macro processor searches for delimiters one at a time.

\*\*\* ERROR #512 DYNAMIC STORAGE (MACROS OR ARGUMENTS) OVERFLOW  
 Either a macro argument was too long (possibly because of a missing delimiter) or enough space is not available because of the number and size of the macro definitions. All pending and active macros and include control lines are popped and scanning continues in the primary source file.

\*\*\* ERROR #513 MACRO STACK OVERFLOW

Excessive recursion in macro calls, expansions, or include control lines has caused the macro stack to overflow. All active macro calls (macros whose values are currently being read, as well as various temporary strings used during the expansion of some built-in macro functions), all pending macro calls (calls to macros whose arguments are still being scanned), and all includes are popped, and scanning continues in the primary source file.

\*\*\* ERROR #514 INPUT STACK OVERFLOW

The input stack is used in conjunction with the macro stack to save pointers to strings under analysis. The cause and recovery is the same as that for ERROR #513 MACRO STACK OVERFLOW.

\*\*\* ERROR #516 LONG PATTERN

An element of a pattern -- an identifier or delimiter -- is longer than 31 characters, or else the total pattern is longer than 255 characters. The `DEFINE` function is aborted and scanning continues from the point at which the error was detected.

\*\*\* ERROR #517 ILLEGAL METACHARACTER

You attempted to change the macro processing metacharacter to an illegal character (a blank, letter, numeral, parenthesis, or asterisk). The current metacharacter remains unchanged.

\*\*\* ERROR #518 UNBALANCED ")" IN ARGUMENT TO USER-DEFINED MACRO

The macro processor encountered an unmatched right parenthesis while scanning a user-defined macro. The macro call is aborted and scanning continues from the point at which the error was detected.

\*\*\* ERROR #519 ILLEGAL ASCENDING CALL

A macro call beginning inside the body of a user-defined macro or built-in macro function was incompletely contained inside that body (possibly because of a missing delimiter for the macro call). The call is aborted.

\*\*\* ERROR #520 BAD CONTROL PARAMETER

A control parameter is out of bounds, of the wrong type, or missing. Check for typographical errors.

See also: Control descriptions, Chapter 3

\*\*\* ERROR #521 MULTIPLE INCLUDE

Only one `INCLUDE` control is allowed on a single line. Only the first (leftmost) `INCLUDE` is processed; the rest are ignored.

\*\*\* ERROR #600 ASM386 INTERNAL ERROR

An internal consistency check has failed. Contact RadiSys, following the instructions on the inside back cover of this manual.

\*\*\* WARNING #601 TOO MANY ERRORS; FURTHER ERROR MESSAGES SUPPRESSED

After the twentieth error on a given source line, this message is given, and no more errors are reported for the line. Normal reporting resumes on the next source line.

\*\*\* ERROR #602 MISSING INPUT FILE

The assembler found the end of the invocation line before a source file specification was scanned.

\*\*\* ERROR #603 INVALID SYNTAX

Check the manual syntax description for this control.

\*\*\* ERROR #604 ILLEGAL DELIMITER

The assembler found a character in a control line or the invocation line that is not a legal delimiter. Check to see that the correct characters were used and that all the parameters were correctly entered.

\*\*\* ERROR #605 MISPLACED PRIMARY CONTROL

Primary controls must appear at the start of the source file before all comments and blank lines.

\*\*\* ERROR #606 UNKNOWN CONTROL

The indicated control is not recognized as an assembler control in this context. It may be misspelled, mistyped, or incorrectly abbreviated.

\*\*\* ERROR #607 EXPECTED LEFT PARENTHESIS

The assembler expected a left parenthesis as the delimiter for a control parameter.

\*\*\* ERROR #608 RESTORE WITHOUT SAVE

A RESTORE control was encountered without a corresponding SAVE control.

\*\*\* ERROR #609 INVALID NUMERIC VALUE

An invalid number was used as a parameter for a control.

\*\*\* ERROR #610 PAGE WIDTH OUT OF RANGE

The parameter for PAGEWIDTH control must be a decimal integer from 60 to 132.

\*\*\* ERROR #611 PAGE LENGTH OUT OF RANGE

The parameter for the PAGELENGTH control must be a decimal integer from 10 to 65535.

\*\*\* ERROR #612 EXPECTED RIGHT PARENTHESIS

The assembler expected a right parenthesis as the delimiter for a control parameter.





# System Hardware and Software Requirements **B**

---

This chapter describes the hardware and software requirements, and the procedure for making required modifications to the operating system.

## Hardware and Software Requirements

- Hardware -- IBM PC XT or IBM PC AT or fully equivalent system
- Operating system -- DOS Version 3.0 or later
- Fixed disk storage capacity -- sufficient for the size of the product (360K bytes)
- System memory requirements -- 512K bytes minimum RAM for ASM386 v3.0, 357K bytes for ASM386 v4.0

# Modifying the System Configuration

Before using the Intel Software Development Tools from DOS, the system configuration file `CONFIG.SYS` must be created or modified to include the `FILES` and `BUFFERS` commands. The `FILES` command specifies the maximum number of the files that can be opened at the same time. The `BUFFERS` command specifies the number of disk buffers allocated in memory. To use Intel Software Development Tools, set the value of `FILES` to 12 (or greater) and set the value of `BUFFERS` to 10 (or greater).

Follow these steps to create the `CONFIG.SYS` file using the DOS `COPY` command:

1. Type:

```
copy con \config.sys <CR>
```

2. Enter the commands:

```
FILES=12 (or greater) <CR>
```

```
BUFFERS=10 (or greater) <CR>
```

3. To save the file, press the F6 key and then press <ENTER>.
4. Reboot the system.

If this file already exists on the system, use an editor to add or modify the existing file by including the commands `FILES=12` (or greater) and `BUFFERS=10` (or greater).



## A

addresses and offsets, 51  
assembler errors, 65  
attributes, 60  
ATTRIBUTES field, 66

## B

binder (BND386), 2  
blank lines, 8  
builder (BLD386), 2

## C

codemacro, 66  
COMM attribute, 61  
command, 5  
command files, 22  
command lines, 6  
comment lines, 8  
control  
    errors, 69  
    line indicator (\$), 14  
    lines, 8, 12, 14  
    parameter delimiters, 6  
    parameters, 12  
    precedence, 12  
    precedence, 11  
controls, 5, 6, 8, 11, 12  
    general, 8  
    in commands, 6  
    in macros, 15  
    within macros, 14

## D

DEBUG control, 27  
debuggers, 50  
descriptor tables, 3  
DOS batch files, 21

## E

EJECT control, 28  
equated symbols, 60  
ERRORPRINT control, 29  
errorprint file, 18, 42  
external symbols, 66

## F

fatal errors, 65  
floating-point coprocessor, 39  
floating-point stack element, 61, 67

## G

GEN control, 31  
general controls, 11  
GENONLY control, 31

## H

hardware/software requirements, 81  
header, 35, 41, 43, 48, 59

## I

I/O errors, 65, 66  
in-circuit emulators, 2  
INCLUDE control, 34

- indexing attribute, 60
- input source, 6
- instruction, 67
- internal errors, 65, 66
- invocation, 21
  - commands, 6
  - examples, 7
  - syntax, 5
- invocation control errors, 65

## K

- keyword, 67

## L

- labels, 67
- librarian (LIB386), 2
- limits, 17
- line numbers, 55, 63
- LIST control, 35
- listing, 35, 44, 47, 54, 55
- listing file, 18
- location counter, 55, 60
- logical files, 18
- logical names, 53

## M

- macro, 18, 55
  - call, 69
  - calls, 31, 34, 36
  - definitions, 12, 13
  - errors, 69
  - expansion, 31, 63
  - metacharacter (%), 5
  - nesting, 14
  - processor, 14, 20
  - string, 5
- MACRO control, 36
- mapper (MAP386), 2
- maximum
  - nesting level, 34
  - nesting level of SAVES, 45
  - page width, 42
  - segment size, 51
  - title length, 48

- minimum page width, 42
- MOD376 control, 37
- MOD386 control, 37
- MOD486 control, 37
- multiple controls, 12

## N

- N287 control, 39
- N387 control, 39
- NAME field, 66
- nesting indicator, 62
- NODEBUG control, 27
- NOERRORPRINT control, 29
- NOGEN control, 31
- NOLIST control, 35
- NOMACRO control, 36
- nonfatal errors, 67
- NOOBJECT control, 40
- NOPAGING control, 43
- NOPRINT control, 44
- NOSYMBOLS control, 47
- NOTYPE control, 50
- NOXREF control, 54
- numbers, 67

## O

- object code, 18, 55, 62
- OBJECT control, 40
- object file, 18, 27, 40
- object files, 2
- object module, 50
- object modules, 1
- OMF-386, 2
- operand sizes, 51
- output file, 6, 18
- output files
  - pathname limitations, 18
- override attribute, 60
- override prefixes, 51

## P

- page tables, 3
- PAGELength control, 41
- PAGEWIDTH control, 42

PAGING control, 43  
parameters, 6  
pathnames  
    limitations, 18  
primary controls, 8, 10  
PRINT control, 44  
print file, 18, 35, 41, 42, 43, 44, 47, 54, 55  
procedures, 67  
program restrictions, 17  
public symbols, 66

## R

record definitions, 60  
records and record fields, 67  
registers, 68  
relocation indicator, 62  
RESTORE control, 45

## S

SAVE control, 45  
scanning modes, 14  
segment and system descriptors, 3  
segments, 68  
severe errors, 20  
sign-off message, 20  
sign-on message, 20  
source code, 55  
source file, 5, 8, 20, 34  
source file controls, 12  
source lines, 18, 29  
source statements, 63  
source text, 31, 55  
stack, 45  
stack segments, 68  
structures and structure fields, 68  
symbol table, 20, 47, 54, 64  
symbol table fields, 66  
symbolic debugging, 27  
SYMBOLS control, 47  
syntax errors, 67, 68  
system utilities, 2

## T

task state segments, 3  
temporary files, 53  
temporary work files, 19  
TITLE control, 48  
TYPE control, 50  
TYPE field, 66

## U

undefined symbols, 68  
USE16 control, 51  
USE32 control, 51  
utilities, 1V  
VALUE field, 66  
variables, 69

## W

warnings, 67, 68  
WORKFILES control, 53

## X

XREF control, 54



The RadiSys logo is a dark blue rounded rectangle with the word "RadiSys." in white serif font. A thin white line extends from the right side of the logo, ending in a small diamond shape that connects to the top of a vertical line running down the page.

RadiSys.

# **ASM386 Assembly Language Reference**

RadiSys Corporation  
5445 NE Dawson Creek Drive  
Hillsboro, OR 97124  
(503) 615-1100  
FAX: (503) 615-1150  
[www.radisys.com](http://www.radisys.com)  
07-0578-01  
December 1999

EPC, iRMX, INtime, Inside Advantage, and RadiSys are registered trademarks of RadiSys Corporation. Spirit, DAI, DAQ, ASM, Brahma, and SAIB are trademarks of RadiSys Corporation.

Microsoft and MS-DOS are registered trademarks of Microsoft Corporation and Windows 95 is a trademark of Microsoft Corporation.

IBM and PC/AT are registered trademarks of International Business Machines Corporation.

Microsoft Windows and MS-DOS are registered trademarks of Microsoft Corporation.

Intel is a registered trademark of Intel Corporation.

All other trademarks, registered trademarks, service marks, and trade names are property of their respective owners.

December 1999

Copyright © 1999 by RadiSys Corporation

All rights reserved

# Quick Contents

---

|                    |                                                                  |
|--------------------|------------------------------------------------------------------|
| <b>Chapter 1.</b>  | <b>Introduction</b>                                              |
| <b>Chapter 2.</b>  | <b>Segmentation</b>                                              |
| <b>Chapter 3.</b>  | <b>Program Linkage Directives</b>                                |
| <b>Chapter 4.</b>  | <b>Defining and Initializing Data</b>                            |
| <b>Chapter 5.</b>  | <b>Accessing Data</b>                                            |
| <b>Chapter 6.</b>  | <b>Processor Instructions</b>                                    |
| <b>Chapter 7.</b>  | <b>Floating-point Instructions</b>                               |
| <b>Chapter 8.</b>  | <b>Textmacros</b>                                                |
| <b>Chapter 9.</b>  | <b>Codemacros</b>                                                |
| <b>Appendix A.</b> | <b>Processor Architecture Summary</b>                            |
| <b>Appendix B.</b> | <b>Sample Program</b>                                            |
| <b>Appendix C.</b> | <b>Keywords and Reserved Words</b>                               |
| <b>Appendix D.</b> | <b>ASCII Tables</b>                                              |
| <b>Appendix E.</b> | <b>Differences Between ASM386 and ASM286</b>                     |
| <b>Appendix F.</b> | <b>Differences Between the Intel386™ and 376 Processors</b>      |
| <b>Appendix G.</b> | <b>Differences Between the Intel386 and Intel486™ Processors</b> |
| <b>Index</b>       |                                                                  |

# Notational Conventions

This manual uses the following conventions:

**UPPERCASE** In syntax descriptions, uppercase indicates keywords or reserved words that must be spelled exactly as shown. They can be entered in either uppercase or lowercase.

Within the text, uppercase indicates a mnemonic, operator, or example code.

*italic* An item in italic is a metasymbol that may be replaced with an item that fulfills the rules for that symbol.

[ ] In syntax descriptions, square brackets indicate an optional part of a statement. If square brackets are required, the syntax shows them in bold fact type, as [ ].

However, in certain register expressions, brackets are required within the actual statement. The descriptions of such statements will indicate this requirement.

... In syntax descriptions, an ellipsis indicates that the preceding argument or parameter may be repeated.

[,...] In syntax descriptions, an ellipsis, preceded by a comma and enclosed in brackets, indicates that the immediately preceding item may be repeated, but that each repetition must be separated by a comma.

:: In examples, a vertical ellipsis indicates that some lines of code have been omitted.

- In syntax descriptions, any punctuation other than ellipses and brackets must be entered as shown. For example, the colon in the following syntax description must be included in a statement:

*label:[instruction]*

- User input, command syntax and computer output are printed like this, in regular monospaced text.
- **In examples combining user input and computer output, user input is printed like this, in bold monospaced text.**

Throughout this manual, the word "may" means "is permitted to".



## Note

Notes indicate important information.



## CAUTION

Cautions indicate situations which may damage hardware or data.

## Related Publications

The following Intel manuals contain detailed information about processor architecture and the assembler for your development system:

- *80386 Programmer's Reference Manual*, order number 230985, describes processor architecture from an application or system programmer's point of view.
- *ASM386 Macro Assembler Operating Instructions*, order number 451290 for DOS and 167675 for VAX/VMS, describes the assembler controls, assembler output, and assembler error messages.
- *Intel386™ DX Microprocessor Hardware Reference Manual*, order number 231732, describes the processor from a system engineer's or hardware designer's point of view.

The following Intel manuals contain detailed information about using floating-point coprocessors with the processor:

- *80386 Programmer's Reference Manual*, order number 230985, Chapter 11, describes coprocessing and multiprocessing.
- *80387 Programmer's Reference Manual*, order number 231917.
- *iAPX 286 Programmer's Reference Manual*, order number 210498, Numerics Supplement section, provides information about the Intel287™ coprocessor.

You may also need the processor systems utilities manual(s).



# Contents

---

## 1 Introduction

|                                                        |    |
|--------------------------------------------------------|----|
| About This Manual .....                                | 23 |
| About This Chapter .....                               | 23 |
| Lexical Elements .....                                 | 24 |
| Character Set.....                                     | 24 |
| Tokens and Separators.....                             | 24 |
| Logical Spaces .....                                   | 25 |
| Delimiters.....                                        | 25 |
| Identifiers.....                                       | 26 |
| Continued Statements and Comments.....                 | 26 |
| Assembler Statements .....                             | 29 |
| Assembler Directives .....                             | 29 |
| Assembler Instructions .....                           | 31 |
| Specifying Assembler Statements.....                   | 38 |
| Specifying Directive Statements .....                  | 38 |
| Specifying Instruction Statements.....                 | 39 |
| Assembler Program Structure.....                       | 40 |
| NAME Directive .....                                   | 41 |
| STACKSEG Directive.....                                | 42 |
| SEGMENT Directive for Data Segments.....               | 42 |
| SEGMENT Directive for the Code Segment.....            | 43 |
| ASSUME Directive.....                                  | 44 |
| END Directive .....                                    | 45 |
| Initializing Segment Registers with Instructions ..... | 45 |
| Initializing DS, ES, FS, and GS .....                  | 46 |
| Initializing SS.....                                   | 47 |

---

## 2 Segmentation

|                                               |    |
|-----------------------------------------------|----|
| Overview of Segmentation.....                 | 49 |
| Defining Code, Data, and Stack Segments ..... | 51 |
| SEGMENT..ENDS Directive .....                 | 51 |
| Specifying EO, ER, RO, or RW Access.....      | 52 |
| Specifying USE32 or USE16.....                | 52 |

|                                                        |    |
|--------------------------------------------------------|----|
| Specifying PUBLIC or COMMON .....                      | 53 |
| Multiple Definitions for a Segment.....                | 54 |
| Lexically Nested or Embedded Segment Definitions ..... | 56 |
| STACKSEG Directive.....                                | 57 |
| Combining Stack and Data Segments .....                | 58 |
| Assuming Segment Access.....                           | 58 |
| ASSUME Directive .....                                 | 59 |
| Specifying Segment Selectors with ASSUME.....          | 60 |
| Specifying ASSUME NOTHING and ASSUME CS:NOTHING...     | 63 |

---

### **3 Program Linkage Directives**

|                                                         |    |
|---------------------------------------------------------|----|
| Modular Programming with NAME and END .....             | 67 |
| NAME Directive .....                                    | 68 |
| END Directive.....                                      | 69 |
| Defining Shared Data with PUBLIC, EXTRN, and COMM ..... | 71 |
| PUBLIC Directive.....                                   | 71 |
| EXTRN Directive.....                                    | 72 |
| Placement of EXTRN .....                                | 73 |
| COMM Directive .....                                    | 74 |

---

### **4 Defining And Initializing Data**

|                                                            |    |
|------------------------------------------------------------|----|
| Overview of Assembler Labels and Variables .....           | 78 |
| Assembler Label and Variable Types .....                   | 78 |
| Assembler Data Values.....                                 | 79 |
| Data Types .....                                           | 80 |
| Numeric Data Value Ranges.....                             | 81 |
| Specifying Assembler Data Values.....                      | 82 |
| Initializing Variables .....                               | 83 |
| How the Assembler Evaluates Constant Expressions .....     | 83 |
| Variables.....                                             | 84 |
| Simple Data Allocations.....                               | 85 |
| Variable Attributes .....                                  | 86 |
| Defining and Initializing Variables of a Simple Type ..... | 87 |
| DBIT Directive.....                                        | 87 |
| DB Directive .....                                         | 89 |
| DW Directive .....                                         | 90 |
| DD Directive .....                                         | 92 |
| DP Directive.....                                          | 94 |
| DQ Directive .....                                         | 96 |
| DT Directive .....                                         | 98 |
| Defining Compound Types and Their Variables .....          | 99 |

|                                     |     |
|-------------------------------------|-----|
| RECORD Directive.....               | 100 |
| Record Allocation Statement.....    | 102 |
| STRUC Directive.....                | 104 |
| Structure Allocation Statement..... | 106 |
| DUP Clause.....                     | 109 |
| Labels .....                        | 111 |
| Label Attributes .....              | 112 |
| The Location Counter.....           | 113 |
| ORG Directive .....                 | 114 |
| EVEN Directive .....                | 114 |
| ALIGN Directive .....               | 115 |
| LABEL Directive.....                | 116 |
| Defining Implicit NEAR Labels ..... | 118 |
| PROC Directive .....                | 119 |
| Using Symbolic Data .....           | 122 |
| EQU Directive .....                 | 123 |
| PURGE Directive.....                | 125 |

---

## 5 Accessing Data

|                                                         |     |
|---------------------------------------------------------|-----|
| Overview of Assembler Expressions .....                 | 127 |
| Constant Expressions.....                               | 128 |
| Address Expressions.....                                | 128 |
| Variable and Label Names as Address Expressions .....   | 129 |
| Register Expressions.....                               | 129 |
| Combining Simple Address and Register Expressions ..... | 130 |
| Structure Fields in Address Expressions .....           | 131 |
| Relocatable Expressions .....                           | 132 |
| Operators .....                                         | 134 |
| Operator Precedence .....                               | 136 |
| Isolation Operators .....                               | 137 |
| Multiplication and Division Operators.....              | 138 |
| Shift Operators .....                                   | 139 |
| Addition and Subtraction Operators.....                 | 140 |
| Relational Operators.....                               | 141 |
| Logical Operators.....                                  | 142 |
| Attribute Value Operators .....                         | 144 |
| THIS Operator.....                                      | 144 |
| SEG Operator .....                                      | 145 |
| OFFSET Operator .....                                   | 146 |
| BITOFFSET Operator .....                                | 147 |
| LENGTH Operator .....                                   | 149 |
| TYPE Operator.....                                      | 149 |

|                                                          |     |
|----------------------------------------------------------|-----|
| SIZE Operator .....                                      | 151 |
| STACKSTART Operator.....                                 | 152 |
| Attribute Override Operators .....                       | 152 |
| Segment Override Operator .....                          | 153 |
| PTR Operator .....                                       | 155 |
| SHORT Operator.....                                      | 157 |
| Record Specific Operators .....                          | 158 |
| WIDTH Operator.....                                      | 158 |
| MASK Operator .....                                      | 159 |
| Using Field Names as Shift Counts .....                  | 160 |
| Instruction Operands .....                               | 161 |
| Register Operands .....                                  | 161 |
| Immediate Operands.....                                  | 162 |
| Memory Operands.....                                     | 162 |
| Memory Addressing Methods.....                           | 163 |
| Direct Memory Addressing.....                            | 164 |
| Indirect Memory Addressing .....                         | 164 |
| Register Indirect Addressing.....                        | 166 |
| Based Addressing .....                                   | 166 |
| Based Indexed Addressing.....                            | 167 |
| Indexed Addressing .....                                 | 167 |
| Scaling .....                                            | 168 |
| Default Segment Registers and Anonymous References ..... | 169 |
| Bit Addressing.....                                      | 170 |

---

## 6 Processor Instructions

|                                                      |     |
|------------------------------------------------------|-----|
| Overview of the Processor Instruction Set .....      | 171 |
| Data Transfer Instructions .....                     | 172 |
| Instructions That Assign Data Values .....           | 172 |
| Instructions That Adjust Data .....                  | 176 |
| Instructions That Make Stack Transfers .....         | 177 |
| Instructions That Yield Definitive Flag Values ..... | 178 |
| Conditional Instructions That Test Flag Values.....  | 179 |
| Control Instructions .....                           | 180 |
| System Instructions .....                            | 181 |
| Instruction Statements .....                         | 182 |
| Instruction Statement Syntax .....                   | 182 |
| Instruction Attributes.....                          | 183 |
| Address Size Attribute .....                         | 184 |
| Operand Size Attribute .....                         | 184 |
| Stack Size Attribute.....                            | 185 |

|                                                                                |     |
|--------------------------------------------------------------------------------|-----|
| Instruction Encoding Format .....                                              | 185 |
| Instruction Prefix Codes .....                                                 | 186 |
| ModRM and SIB Bytes.....                                                       | 188 |
| Processor Instruction Set Reference .....                                      | 193 |
| How to Read the Instruction Set Reference Pages.....                           | 193 |
| Opcode Column.....                                                             | 194 |
| Instruction Column.....                                                        | 195 |
| Clocks Column.....                                                             | 200 |
| Description Column.....                                                        | 201 |
| Operation Section.....                                                         | 201 |
| Discussion Section.....                                                        | 207 |
| Flags Affected Section.....                                                    | 207 |
| Exceptions by Mode Section .....                                               | 207 |
| How to Look Up an Instruction .....                                            | 210 |
| Processor Instructions.....                                                    | 212 |
| AAA  ASCII Adjust after Addition.....                                          | 212 |
| AAD  ASCII Adjust AX before Division .....                                     | 214 |
| AAM  ASCII Adjust AX after Multiply.....                                       | 215 |
| AAS  ASCII Adjust AL after Subtraction .....                                   | 216 |
| ADC  Add with Carry.....                                                       | 218 |
| ADD  (Integer) Add.....                                                        | 220 |
| AND  Logical AND.....                                                          | 222 |
| ARPL Adjust RPL Field of Selector .....                                        | 224 |
| BOUND Check Array Index Against Bounds .....                                   | 226 |
| BSF  Bit Scan Forward.....                                                     | 228 |
| BSR  Bit Scan Reverse.....                                                     | 230 |
| BSWAP Byte Swap (not available on Intel386 or<br>376 processors) .....         | 232 |
| BT  Bit Test.....                                                              | 233 |
| BTC  Bit Test and Complement.....                                              | 236 |
| BTR  Bit Test and Reset.....                                                   | 239 |
| BTS  Bit Test and Set.....                                                     | 242 |
| CALL Call Procedure.....                                                       | 245 |
| CBW/CWDE Convert Byte to Word/Convert Word to Dword....                        | 252 |
| CLC  Clear Carry Flag .....                                                    | 253 |
| CLD  Clear Direction Flag .....                                                | 254 |
| CLI  Clear Interrupt Flag.....                                                 | 255 |
| CLTS Clear Task Switched Flag in CR0.....                                      | 256 |
| CMC  Complement Carry Flag.....                                                | 257 |
| CMP  Compare Two Operands .....                                                | 258 |
| CMPS/CMPSB/CMPSW/CMPSD Compare String Operands .....                           | 260 |
| CMPXCHG Compare Exchange (not available on Intel386<br>or 376 processors)..... | 263 |

## 6 Processor Instructions (continued)

|                                                                                                         |     |
|---------------------------------------------------------------------------------------------------------|-----|
| CWD/CDQ Convert Word to Dword/Convert Dword to Qword..                                                  | 265 |
| DAA Decimal Adjust AL after Addition.....                                                               | 267 |
| DAS Decimal Adjust AL after Subtraction .....                                                           | 268 |
| DEC Decrement by 1.....                                                                                 | 269 |
| DIV Unsigned Divide .....                                                                               | 270 |
| ENTER Make Stack Frame for Procedure Parameters .....                                                   | 272 |
| HLT Halt.....                                                                                           | 274 |
| IDIV Signed Divide.....                                                                                 | 275 |
| IMUL Signed Multiply .....                                                                              | 277 |
| IN Input from Port .....                                                                                | 280 |
| INC Increment by 1 .....                                                                                | 282 |
| INS/INSB/INSW/INSD Input from Port to String .....                                                      | 283 |
| INT/INTO Transfer Control to Interrupt Procedure.....                                                   | 286 |
| INVD Invalidate Data Cache (not available on Intel386 or 376<br>processors) .....                       | 292 |
| INVLPG Invalidate Paging Cache Entry (not available on<br>Intel386 or 376 processors) .....             | 293 |
| IRET/IRETD Interrupt Return .....                                                                       | 294 |
| Jcc Jump if Condition is Met .....                                                                      | 299 |
| JMP Jump.....                                                                                           | 304 |
| LAHF Load Flags into AH Register.....                                                                   | 310 |
| LAR Load Access Rights.....                                                                             | 311 |
| LDS/LES/LFS/LGS/LSS Load Full Pointer .....                                                             | 314 |
| LEA Load Effective Address .....                                                                        | 317 |
| LEAVE High Level Procedure Exit .....                                                                   | 319 |
| LGDT/LIDT Load Global/Interrupt Descriptor Table Register ...                                           | 320 |
| LGDTW/LGDTD/LIDTW/LIDTD Load Global/Interrupt<br>Descriptor Table Register with WORD/DWORD Operand..... | 322 |
| LLDT Load Local Descriptor Table Register.....                                                          | 324 |
| LMSW Load Machine Status Word .....                                                                     | 326 |
| LOCK Assert Bus LOCK# Signal Prefix.....                                                                | 327 |
| LODS/LODSB/LODSW/LODSD Load String Operand.....                                                         | 329 |
| LOOP/LOOPcond Loop Control with (E)CX Counter .....                                                     | 331 |
| LSL Load Segment Limit .....                                                                            | 333 |
| LTR Load Task Register.....                                                                             | 336 |
| MOV Move Data.....                                                                                      | 338 |
| MOV Move to/from Special Registers .....                                                                | 341 |
| MOVS/MOVSb/MOVSW/MOVSd Move String to String.....                                                       | 343 |
| MOVSX Move with Sign-Extend .....                                                                       | 346 |
| MOVZX Move with Zero-Extend.....                                                                        | 347 |
| MUL Unsigned Multiplication of AL, AX or EAX .....                                                      | 348 |
| NEG Two's Complement Negation.....                                                                      | 350 |

|                         |                                                                                             |     |
|-------------------------|---------------------------------------------------------------------------------------------|-----|
| NOP                     | No Operation .....                                                                          | 351 |
| NOT                     | One's Complement Negation.....                                                              | 352 |
| OR                      | Logical Inclusive OR .....                                                                  | 353 |
| OUT                     | Output to Port.....                                                                         | 355 |
| OUTS/OUTSB/OUTSW/OUTSD  | Output String to Port.....                                                                  | 357 |
| POP                     | Pop Stack Top .....                                                                         | 360 |
| POPA/POPAD              | Pop All General Registers .....                                                             | 363 |
| POPF/POPFD              | Pop Stack into FLAGS or EFLAGS Register .....                                               | 365 |
| PUSH                    | Push Operand onto the Stack.....                                                            | 367 |
| PUSHA/PUSHAD            | Push all General Registers.....                                                             | 369 |
| PUSHF/PUSHFD            | Push Flags Register onto the Stack.....                                                     | 371 |
| RCL/RCR/ROL/ROR         | Rotate.....                                                                                 | 372 |
| RET                     | Return from Procedure .....                                                                 | 381 |
| SAHF                    | Store AH into Flags .....                                                                   | 386 |
| SAL/SAR/SHL/SHR         | Shift.....                                                                                  | 387 |
| SBB                     | Integer Subtraction with Borrow.....                                                        | 391 |
| SCAS/SCASB/SCASW/SCASD  | Compare String Data .....                                                                   | 393 |
| SETcc                   | Byte Set on Condition .....                                                                 | 395 |
| SGDT/SIDT               | Store Global/Interrupt Descriptor Table Register ....                                       | 397 |
| SGDTW/SGDTD/SIDTW/SIDTD | Store Global/Interrupt<br>Descriptor Table Register with WORD/DWORD Operand .....           | 399 |
| SHLD                    | Double Precision Shift Left .....                                                           | 400 |
| SHRD                    | Double Precision Shift Right .....                                                          | 402 |
| SLDT                    | Store Local Descriptor Table Register.....                                                  | 404 |
| SMSW                    | Store Machine Status Word .....                                                             | 405 |
| STC                     | Set Carry Flag .....                                                                        | 406 |
| STD                     | Set Direction Flag .....                                                                    | 407 |
| STI                     | Set Interrupt Flag.....                                                                     | 408 |
| STOS/STOSB/STOSW/STOSD  | Store String Data.....                                                                      | 409 |
| STR                     | Store Task Register .....                                                                   | 411 |
| SUB                     | Integer Subtraction.....                                                                    | 412 |
| TEST                    | Logical Compare.....                                                                        | 414 |
| VERR/VERW               | Verify a Segment for Reading or Writing.....                                                | 416 |
| WAIT                    | Wait until BUSY# Pin is Inactive (HIGH).....                                                | 418 |
| WBINVD                  | Write Back And Invalidate Data Cache<br>(not available on Intel386 or 376 processors) ..... | 419 |
| XADD                    | Exchange Add (not available on Intel386 or<br>376 processors) .....                         | 420 |
| XCHG                    | Exchange Register/Memory with Register .....                                                | 422 |
| XLAT/XLATB              | Table Look-up Translation .....                                                             | 424 |
| XOR                     | Logical Exclusive OR.....                                                                   | 426 |

---

## 7 Floating-Point Instructions

|                                                                 |     |
|-----------------------------------------------------------------|-----|
| Floating-point Coprocessor Architecture .....                   | 429 |
| Floating-point Stack .....                                      | 430 |
| Environment.....                                                | 431 |
| Status Word.....                                                | 433 |
| Control Word.....                                               | 435 |
| Tag Word .....                                                  | 438 |
| Operation Locator Formats .....                                 | 439 |
| Floating-point Coprocessor Data Formats.....                    | 440 |
| Coprocessor Operation .....                                     | 443 |
| Numeric Processing.....                                         | 444 |
| Overview of the Floating-point Coprocessor Instruction Set..... | 446 |
| Data Transfer Instructions .....                                | 446 |
| Constant Instructions .....                                     | 447 |
| Algebraic Instructions.....                                     | 448 |
| Comparison Instructions.....                                    | 451 |
| Transcendental Instructions .....                               | 452 |
| Coprocessor Control Instructions.....                           | 453 |
| Floating-point Coprocessor Instruction Set Reference .....      | 454 |
| How to Read the Instruction Set Reference Pages.....            | 454 |
| Opcode Column.....                                              | 454 |
| Instruction Column .....                                        | 455 |
| Clocks Columns.....                                             | 455 |
| Description Column.....                                         | 455 |
| Discussion Section.....                                         | 456 |
| Exceptions Section .....                                        | 456 |
| How to Look Up an Instruction .....                             | 456 |
| F2XM1 Compute $Y = 2^X - 1$ .....                               | 457 |
| FABS Absolute Value.....                                        | 458 |
| FADD/FADDP Real Addition.....                                   | 459 |
| FBLD BCD Load to Real .....                                     | 460 |
| FBSTP BCD Store and Pop .....                                   | 461 |
| FCHS Change Sign of Real Number .....                           | 462 |
| FCLEX/FNCLEX Clear Floating-point Coprocessor Exceptions .....  | 463 |
| FCOM/FCOMP/FCOMPP Compare Real Numbers .....                    | 464 |
| FCOS Compute $Y = \text{Cos}(X)$ .....                          | 466 |
| FDECSTP Decrement Floating-point Stack Pointer .....            | 467 |
| FDIV/FDIVP/FDIVR/FDIVRP Real Divide/Real<br>Reverse Divide..... | 468 |
| FFREE Free Floating-point Stack Entry.....                      | 469 |
| FIADD Integer Add to Real.....                                  | 470 |
| FICOM/FICOMP Integer Compare with Real.....                     | 471 |

|                         |                                                        |     |
|-------------------------|--------------------------------------------------------|-----|
| FIDIV/FIDIVR            | Integer Divide into Real.....                          | 473 |
| FILD                    | Integer Load into Real .....                           | 474 |
| FIMUL                   | Integer Multiply with Real.....                        | 475 |
| FINCSTP                 | Increment Floating-point Stack Pointer .....           | 476 |
| FINIT/FNINIT            | Initialize Floating-point Coprocessor.....             | 477 |
| FIST/FISTP              | Integer Store from Real .....                          | 479 |
| FISUB/FISUBR            | Integer Subtract from Real .....                       | 480 |
| FLD                     | Load Real.....                                         | 481 |
| FLDCW                   | Load Floating-point Coprocessor Control Word.....      | 482 |
| FLDENV                  | Load Floating-point Coprocessor Environment.....       | 483 |
| FLDcon                  | Load Real Constant .....                               | 484 |
| FMUL/FMULP              | Multiply Real.....                                     | 485 |
| FNOP                    | No Operation .....                                     | 486 |
| FPATAN                  | Compute R = Partial Arctangent.....                    | 487 |
| FPREM/FPREM1            | Partial Remainder.....                                 | 489 |
| FPTAN                   | Compute Y = Partial Tan(X) .....                       | 492 |
| FRNDINT                 | Round to Integer .....                                 | 493 |
| FRSTOR                  | Restore Floating-point Coprocessor Machine State ..... | 494 |
| FSAVE/FNSAVE            | Save Floating-point Coprocessor<br>Machine State.....  | 495 |
| FSCALE                  | Scale Exponent of Real .....                           | 499 |
| FSETPM                  | Set Protected Mode .....                               | 500 |
| FSIN                    | Compute Y = Sin(X).....                                | 501 |
| FSINCOS                 | Compute Y = Sin(X) and Y = Cos(X) .....                | 502 |
| FSQRT                   | Square Root.....                                       | 503 |
| FST/FSTP                | Store Real/Store Real and Pop.....                     | 504 |
| FSTCW/FNSTCW            | Store Floating-point Coprocessor<br>Control Word.....  | 505 |
| FSTENV/FNSTENV          | Store Floating-point Coprocessor<br>Environment .....  | 506 |
| FSTSW/FNSTSW            | Store Floating-point Coprocessor Status Word .....     | 507 |
| FSUB/FSUBP/FSUBR/FSUBRP | Subtract Real.....                                     | 508 |
| FTST                    | Test Real (Compare to Zero) .....                      | 509 |
| FUCOM/FUCOMP/FUCOMPP    | Unordered Comparison of<br>Real Numbers .....          | 510 |
| FWAIT                   | Wait for Floating-point Operation Complete .....       | 512 |
| FXAM                    | Examine Floating-point Stack Top .....                 | 513 |
| FXCH                    | Exchange Real Numbers in Stack.....                    | 514 |
| FXTRACT                 | Extract Exponent and Significand of Real.....          | 515 |
| FYL2X                   | Compute Y * log <sub>2</sub> X.....                    | 517 |
| FYL2XP1                 | Compute Y * log <sub>2</sub> (X + 1).....              | 517 |

---

## 8 Textmacros

|                                                           |     |
|-----------------------------------------------------------|-----|
| Overview.....                                             | 519 |
| Macro Processing .....                                    | 521 |
| Macro Calls and Call Patterns.....                        | 521 |
| Macro Processor Scanning Modes and Macro Expansions ..... | 522 |
| Predefined Macros.....                                    | 523 |
| Macro Arguments.....                                      | 525 |
| Balanced Text.....                                        | 525 |
| Delimiters in Call Patterns.....                          | 526 |
| Identifiers .....                                         | 527 |
| Expressions.....                                          | 527 |
| Argument Evaluations .....                                | 528 |
| Predefined Macro Reference .....                          | 529 |
| DEFINE Macro .....                                        | 530 |
| Bracket Macro.....                                        | 534 |
| Escape Macro .....                                        | 535 |
| Comment Macro.....                                        | 537 |
| METACHAR Macro .....                                      | 538 |
| EVAL Macro.....                                           | 539 |
| SET Macro .....                                           | 540 |
| IF Macro .....                                            | 541 |
| WHILE Macro .....                                         | 543 |
| REPEAT Macro .....                                        | 544 |
| EXIT Macro .....                                          | 545 |
| String Comparison Macros .....                            | 546 |
| LEN Macro .....                                           | 548 |
| SUBSTR Macro .....                                        | 548 |
| MATCH Macro .....                                         | 549 |
| Console I/O Macros.....                                   | 551 |
| Scanning Modes, Delimiters, and Macro Expansions.....     | 552 |
| Normal and Literal Scanning Modes.....                    | 552 |
| Macro Delimiters.....                                     | 553 |
| Literal Delimiters .....                                  | 553 |
| Implied Blank Delimiters.....                             | 555 |
| Identifier Delimiters .....                               | 555 |
| Algorithm for Evaluating Macro Calls.....                 | 556 |

---

|          |                                                     |     |
|----------|-----------------------------------------------------|-----|
| <b>9</b> | <b>Codemacros</b>                                   |     |
|          | Overview .....                                      | 559 |
|          | Codemacro Definitions and Calls .....               | 560 |
|          | Processor Instruction Format .....                  | 562 |
|          | Codemacro Reference .....                           | 565 |
|          | CODEMACRO Directive .....                           | 566 |
|          | Formal Parameters and Specifiers.....               | 568 |
|          | Formal Parameter Modifiers.....                     | 569 |
|          | Formal Parameter Range Specifiers.....              | 571 |
|          | PREFIX67 Directive .....                            | 572 |
|          | PREFIX66 Directive .....                            | 572 |
|          | SEGFIX Directive .....                              | 574 |
|          | NOSEGFIX Directive.....                             | 575 |
|          | WARNING Directive.....                              | 576 |
|          | MODRM Directive.....                                | 577 |
|          | Data Initialization Directives.....                 | 578 |
|          | Record Initialization Directive .....               | 579 |
|          | Using the Dot Operator to Shift Parameters.....     | 580 |
|          | PROCLLEN Function.....                              | 581 |
|          | Relative Displacement Directives.....               | 582 |
|          | Matching Codemacro Calls to Their Definitions ..... | 584 |

---

|          |                                                                 |     |
|----------|-----------------------------------------------------------------|-----|
| <b>A</b> | <b>Processor Architecture Summary</b>                           |     |
|          | Basic Processor Formats.....                                    | 588 |
|          | Data Type Formats .....                                         | 588 |
|          | Processor Registers.....                                        | 591 |
|          | General, Segment, Status and Instruction Registers .....        | 591 |
|          | System Registers .....                                          | 594 |
|          | Processor Memory Organization .....                             | 596 |
|          | Segment Selection and Effective Address Computation.....        | 597 |
|          | Segmented Memory Management .....                               | 599 |
|          | Segment Descriptors.....                                        | 601 |
|          | Descriptor Address Translation Fields .....                     | 602 |
|          | Descriptor Access Rights (AR).....                              | 602 |
|          | Descriptor Tables and Selector Format.....                      | 603 |
|          | Processor Protection, Gate Descriptors, and Task Switches ..... | 604 |
|          | Protection and Privilege Levels .....                           | 605 |
|          | Protected Control Transfers Use Gate Descriptors .....          | 606 |
|          | Call Gate Descriptor Format.....                                | 607 |
|          | Task Gate, TSS Descriptor, and TSS Format .....                 | 607 |
|          | I/O Permission Bit Map .....                                    | 610 |

|                                                                  |     |
|------------------------------------------------------------------|-----|
| Processor Flags.....                                             | 612 |
| Status Flags .....                                               | 613 |
| Carry Flag .....                                                 | 614 |
| Parity Flag .....                                                | 615 |
| Auxiliary Carry Flag.....                                        | 615 |
| Zero Flag .....                                                  | 615 |
| Sign Flag .....                                                  | 615 |
| Overflow Flag.....                                               | 616 |
| Control and System Control Flags .....                           | 616 |
| Processor Exceptions and Interrupts .....                        | 618 |
| Identifying Interrupts.....                                      | 619 |
| Simultaneous Exceptions and Interrupts .....                     | 621 |
| Interrupt Descriptor Table .....                                 | 621 |
| Error Codes for Exceptions.....                                  | 623 |
| Processor Exception Conditions.....                              | 624 |
| Interrupt 0 -- Divide Error.....                                 | 624 |
| Interrupt 1 -- Debug Exceptions.....                             | 624 |
| Interrupt 2 -- NMI.....                                          | 624 |
| Interrupt 3 -- Breakpoint.....                                   | 624 |
| Interrupt 4 -- Overflow .....                                    | 625 |
| Interrupt 5 -- Bounds Check.....                                 | 625 |
| #UD 6 -- Undefined Opcode (No Error Code).....                   | 625 |
| #NM 7 -- No Math Unit Available (No Error Code).....             | 626 |
| #DF 8 -- Double Fault (Zero Error Code).....                     | 626 |
| Interrupt 9 -- Coprocessor Segment Overrun.....                  | 626 |
| #TS 10 -- Invalid Task State Segment (Selector Error Code) ..... | 627 |
| #NP 11 -- Not Present (Selector Error Code).....                 | 627 |
| #SS 12 -- Stack Fault (Selector or Zero Error Code) .....        | 628 |
| #GP 13 -- General Protection (Selector or Zero Error Code).....  | 629 |
| #PF 14 -- Page Fault (Type of Fault).....                        | 630 |
| #MF 16 -- Math Fault (No Error Code).....                        | 631 |

---

## **B Sample Program**

|                          |     |
|--------------------------|-----|
| Sample Source Code ..... | 633 |
| Sample Listing .....     | 640 |

---

## **C Keywords And Reserved Words**

651

|          |                                                                  |     |
|----------|------------------------------------------------------------------|-----|
| <b>D</b> | <b>ASCII Tables</b>                                              | 655 |
| <hr/>    |                                                                  |     |
| <b>E</b> | <b>Differences Between ASM386 and ASM286</b>                     | 659 |
|          | New Processor Registers .....                                    | 659 |
|          | New Instructions .....                                           | 659 |
|          | Processor Paging Mechanism .....                                 | 660 |
|          | Addressing Differences .....                                     | 660 |
|          | Data Types .....                                                 | 661 |
|          | Bit Manipulation .....                                           | 661 |
|          | Assembler Directives .....                                       | 661 |
|          | Assembler Operators .....                                        | 661 |
|          | Assembler Arithmetic .....                                       | 662 |
|          | Prefix66 and Prefix67 Codemacro Directives .....                 | 662 |
| <hr/>    |                                                                  |     |
| <b>F</b> | <b>Differences Between the Intel386™ and 376 Processors</b>      | 663 |
| <hr/>    |                                                                  |     |
| <b>G</b> | <b>Differences Between the Intel386 and Intel486™ Processors</b> | 667 |
| <hr/>    |                                                                  |     |
|          | <b>Index</b>                                                     | 669 |
| <hr/>    |                                                                  |     |

---

## Tables

|       |                                                                |     |
|-------|----------------------------------------------------------------|-----|
| 1-1.  | Assembler Directives .....                                     | 29  |
| 1-2.  | Processor Instructions.....                                    | 31  |
| 1-3.  | Floating-point Instructions.....                               | 36  |
| 4-1.  | Assembler Variable Types and Numerical Value Ranges .....      | 81  |
| 4-2.  | Assembler Data Value Specification Rules.....                  | 82  |
| 5-1.  | Assembler Operators .....                                      | 134 |
| 5-2.  | Assembler Operator Precedence .....                            | 136 |
| 5-3.  | TYPE Operator Results .....                                    | 150 |
| 5-4.  | PTR Result Attributes .....                                    | 155 |
| 6-1.  | External I/O Instructions .....                                | 172 |
| 6-2.  | Internal Load and Store Instructions .....                     | 173 |
| 6-3.  | Instructions That Make Uncalculated Value Assignments .....    | 174 |
| 6-4.  | Instructions That Make Calculated Value Assignments .....      | 175 |
| 6-5.  | Data Conversion Instructions.....                              | 176 |
| 6-6.  | Shift and Rotate Instructions .....                            | 176 |
| 6-7.  | Stack Transfer Instructions .....                              | 177 |
| 6-8.  | Processor Instructions That Yield Definitive Flag Values ..... | 178 |
| 6-9.  | Conditional Instructions That Test Flag Values .....           | 180 |
| 6-10. | Control Transfer Instructions.....                             | 180 |
| 6-11. | Processor Control Instructions .....                           | 180 |
| 6-12. | Generation of Address and Operand Size Prefixes .....          | 187 |
| 6-13. | 16-Bit Addressing Forms with ModRM Byte in Hexadecimal .....   | 190 |
| 6-14. | 32-Bit Addressing Forms with ModRM Byte in Hexadecimal .....   | 191 |
| 6-15. | 32-Bit Addressing Forms with SIB Byte in Hexadecimal .....     | 192 |
| 6-16. | Processor Exceptions and Interrupts .....                      | 209 |
| 6-17. | Operands and Implicit Destinations for DIV.....                | 270 |
| 6-18. | Operands and Implicit Destinations for IDIV.....               | 275 |
| 6-19. | When IMUL Clears CF and OF.....                                | 278 |
| 6-20. | JMP Label Types, Operand Sizes and Instructions.....           | 308 |
| 6-21. | System Descriptor Types for LAR.....                           | 312 |
| 6-22. | System Descriptor Types for LSL.....                           | 334 |
| 7-1.  | Summary of Real Format Parameters .....                        | 442 |
| 7-2.  | Rounding Methods .....                                         | 444 |
| 7-3.  | Data Transfer Instructions .....                               | 446 |
| 7-4.  | Constant Instructions .....                                    | 447 |
| 7-5.  | Algebraic Instructions .....                                   | 448 |
| 7-6.  | Basic Arithmetic Instruction and Operand Forms .....           | 449 |
| 7-7.  | Comparison Instructions.....                                   | 451 |
| 7-8.  | Transcendental Instructions .....                              | 452 |
| 7-9.  | Processor Control Instructions.....                            | 453 |
| 7-10. | Condition Code after FCOM(P/PP) .....                          | 465 |

|       |                                                              |     |
|-------|--------------------------------------------------------------|-----|
| 7-11. | Condition Code after FICOM(P) .....                          | 471 |
| 7-12. | Floating-point Coprocessor State Following FINIT/FNINIT..... | 478 |
| 7-13. | FPATAN Final Result Octant.....                              | 487 |
| 7-14. | Condition Code after FPREM/FPREM1 .....                      | 490 |
| 7-15. | Condition Code after FTST .....                              | 509 |
| 7-16. | Condition Code after FUCOM(P/PP).....                        | 511 |
| 7-17. | Condition Code after FXAM.....                               | 513 |
| 8-1.  | Predefined Macros .....                                      | 524 |
| 8-2.  | Predefined Macro Call Patterns .....                         | 529 |
| 9-1.  | Codemacro Syntax Summary .....                               | 565 |
| A-1.  | Default Segment Register Selection Rules.....                | 597 |
| A-2.  | Processor Exceptions and Interrupts .....                    | 620 |
| C-1.  | Assembler Keywords .....                                     | 652 |
| C-2.  | Assembler Reserved Words.....                                | 652 |
| D-1.  | ASCII Collating Sequence .....                               | 655 |
| D-2.  | ASCII Non-Printable Characters .....                         | 657 |

---

## Figures

|       |                                                                   |     |
|-------|-------------------------------------------------------------------|-----|
| 1-1.  | Template for an Assembler Program .....                           | 40  |
| 1-2.  | An ASM386 Example Program .....                                   | 41  |
| 4-1.  | Partial Record Definition Template.....                           | 101 |
| 5-1.  | Effective Address Calculation .....                               | 164 |
| 6-1.  | Instruction Encoding Format .....                                 | 185 |
| 6-2.  | ModRM and SIB Byte Formats .....                                  | 188 |
| 6-3.  | BitOffset for BIT[EAX,21] .....                                   | 203 |
| 6-4.  | Memory Bit Indexing.....                                          | 204 |
| 7-1.  | Floating-point Coprocessor Stack Fields .....                     | 430 |
| 7-2.  | 16-bit Environments.....                                          | 432 |
| 7-3.  | 32-bit Environments.....                                          | 433 |
| 7-4.  | Status Word Format .....                                          | 434 |
| 7-5.  | Control Word Format.....                                          | 436 |
| 7-6.  | Tag Word Format.....                                              | 438 |
| 7-7.  | 16-bit Opcode, IP, and Op Environment Formats .....               | 439 |
| 7-8.  | 32-bit Opcode, IP, and OP Environment Formats .....               | 440 |
| 7-9.  | Data Formats.....                                                 | 441 |
| 7-10. | Floating-point Coprocessor Machine State Layout after FSAVE ..... | 497 |
| 9-1.  | Instruction Encoding Format .....                                 | 562 |
| 9-2.  | ModRM and SIB Byte Formats .....                                  | 563 |
| A-1.  | Fundamental Data Types.....                                       | 588 |
| A-2.  | Processor Data Types and Storage Formats .....                    | 589 |
| A-3.  | General, Segment, Status, and Instruction Registers .....         | 592 |
| A-4.  | Processor Stack with Stack Frame.....                             | 593 |

## Figures (continued)

|       |                                                            |     |
|-------|------------------------------------------------------------|-----|
| A-5.  | System Control Registers .....                             | 594 |
| A-6.  | Memory Segmentation Model for ASM386 Programs .....        | 596 |
| A-7.  | Effective Address Calculation .....                        | 598 |
| A-8.  | Processor Address Translation Overview.....                | 599 |
| A-9.  | Segment Address Translation in a Paged System.....         | 600 |
| A-10. | General Segment Descriptor Formats .....                   | 601 |
| A-11. | Selector Format.....                                       | 603 |
| A-12. | Processor Privilege Check for Data Access.....             | 605 |
| A-13. | Call Gate Descriptor Format.....                           | 607 |
| A-14. | Task Gate Descriptor Format.....                           | 607 |
| A-15. | TSS Descriptor Format for 32-bit TSS.....                  | 608 |
| A-16. | General Segment Descriptor Formats .....                   | 609 |
| A-17. | I/O Address Bit Map .....                                  | 611 |
| A-18. | Processor EFLAGS Register.....                             | 612 |
| A-19. | Status Flags Format.....                                   | 613 |
| A-20. | Control Flags and IOPL Format.....                         | 616 |
| A-21. | Interrupt Descriptor Table and Register.....               | 621 |
| A-22. | IDT Gate Descriptors .....                                 | 622 |
| G-1.  | Intel486 Processor Control Registers .....                 | 669 |
| G-2.  | Intel486 Processor Page Table/Directory Entry Format ..... | 669 |
| G-3.  | Intel486 Processor EFLAGS Register.....                    | 670 |

## About This Manual

ASM386 supports the Pentium® and Intel486™ microprocessors and the entire Intel386™ family, including the Intel386, Intel386 SX, and 376 microprocessors, as well as the Intel287™, Intel387™ and Intel387 SX floating-point coprocessors. Throughout this manual, the word "processor" refers to any of the above microprocessors and the words "floating-point coprocessor" refer to any of the above coprocessors, as well as the Pentium and Intel486 processors' built-in floating-point functions.

This manual is a reference for the ASM386 assembly language. It assumes that you are familiar with assembly language programming and 8086/286/Intel386 processor architecture. Read Appendix A if you are already familiar with the 8086/286 processor architecture(s). If you aren't, see the *80386 Programmer's Reference Manual*.

## About This Chapter

This chapter introduces the assembly language. It has three major sections:

- Lexical Elements

This section describes the assembler character set, tokens, separators, identifiers, comments, and the difference between source file lines and logical statement lines.

- Statements

This section introduces the assembler directives, processor instruction set, and floating-point instruction set.

- Program Structure

This section provides a template for assembler programs together with a simple example program (see Appendix B for another example program). It summarizes the essential parts of every ASM386 program.

# Lexical Elements

This section describes the lexical elements of the assembly language, except for its keywords and reserved words.

See also:    Keywords and reserved words, Appendix C

## Character Set

The assembler character set is a subset of the ASCII character set. Each character in a source file should be one of the following:

Alphanumerics:    ABCDEFGHIJKLMNOPQRSTUVWXYZ  
                  abcdefghijklmnopqrstuvwxyz  
                  0123456789

Special Characters: + - \* / ( ) [ ] < > ; ' . " \_ : ? @ \$ &

Logical Delimiters: space tab carriage\_return line\_feed

If a program contains any character that is not in the preceding set, the assembler treats the character as a logical space.

Uppercase and lowercase letters are not distinguished from each other except in character strings. For example, xyz and XYZ are interchangeable, but 'xyz' and 'XYZ' are not equivalent character strings.

The special characters and combinations of special characters have particular meanings in a program, as described throughout this manual.

See also:    ASCII character set, Appendix D

## Tokens and Separators

A token is the smallest meaningful unit of a source program, much as words are the smallest meaningful units of a sentence. A token is one of the following:

- An end of statement
- A delimiter
- An identifier
- A constant
- An assembler keyword or reserved word

A separator that is a logical space or a delimiter must be specified between two adjacent tokens that are identifiers, constants, keywords, and/or reserved words. The most commonly used separator is the space character.

The end of statement token must be specified between two adjacent statements. The most commonly used statement terminator is the carriage\_return/line\_feed character combination.

See also: Constants, Chapter 4  
keywords and reserved words, Appendix C

## Logical Spaces

Any unbroken sequence of spaces can be used wherever a single space character is valid. Horizontal tabs are also used as token separators. The assembler interprets horizontal tabs as a single logical space. However, tabs are reproduced as multiple space characters in the print (listing) file to maintain the appearance of the source file.

See also: Print file, *ASM386 Macro Assembler Operating Instructions*

Logical spaces may not be specified within tokens such as identifiers, constants, keywords, or reserved words. The assembler treats any invalid character(s) in the context of a source file as a separator.

## Delimiters

Like logical spaces, delimiters mark the end of a token, but each delimiter has a different special meaning. Some examples are commas and colons.

When a delimiter is present, a logical space between two tokens need not be specified. However, extra space or tab characters often make programs easier to read.

Delimiters are described in context throughout this manual.

## Identifiers

An identifier is a name for a programmer-defined entity such as a segment, variable, label, or constant. Valid identifiers conform to the following rules:

- The initial character must be a letter (A...Z or a...z) or one of the following special characters:
  - ? A question mark (ASCII value: 3FH)
  - @ An at sign (ASCII value: 40H)
  - \_ An underscore (ASCII value: 5FH)
- The remaining characters may be letters, digits (0..9), and the preceding special characters. Separators may not be specified within identifiers.
- An identifier may be up to 255 characters in length; it is considered unique only up to 31 characters.
- Every identifier within a program module represents one and only one entity. A named entity is accessible from anywhere in the module when it is referenced by name. The assembler does not have identifier scope rules that allow you to specify the same name for two distinct entities in different contexts.

## Continued Statements and Comments

An assembler statement usually occupies a single source file line. A source file line is a sequence of characters ended by a valid line delimiter:

- Either a `line_feed` character
- Or, a `carriage_return/line_feed` combination

However, the end of line in a source file is not necessarily the logical end of a statement. Assembler statements do terminate with a `line_feed` or `carriage_return/line_feed` combination, but logical statements can extend over several lines by using the continuation character (`&`).

The end of line in a source file always terminates a comment. The semicolon (`;`) is the initial character of a comment.

Valid comments and statements conform to the following rules:

- A comment begins with a semicolon (;) and ends when the line that contains it is terminated. The assembler ignores comments.
- A statement or comment may be continued on subsequent continuation lines. The first character following the line terminator that is not a logical space must be an ampersand (&).
- Statements and comments may extend over many source file lines if they conform to the following:
  - Symbols (such as identifiers, keywords, and reserved words) cannot be broken across continuation lines.
  - Character strings must be closed with an apostrophe on one line and reopened with an apostrophe on a subsequent continuation line, with an intervening comma (,) after the ampersand. Space and tab characters within a character string are significant; they are not treated as logical spaces.
  - If a comment is continued, the first character following the ampersand that is not a logical space must be a semicolon (;).

## Examples

The following examples illustrate the difference between the end of a source file line and the logical end of an assembler statement. The notation `<cr_lf>` represents a carriage\_return/line\_feed. Both examples are equivalent.

1. This example has a single statement on a single source file line. The end of the source file line and the logical end of the statement are the same.

```
;          1          2          3          4<cr_lf>
; 2345678901234567890123456789012345678901234567890<cr_lf>
<cr_lf>          ; interpreted as logical space
MOV EAX, FOO<cr_lf>
```

2. This example has many ends of lines in the source file, but it has only one logical end of statement.

```
;          1          2          3          4<cr_lf>
; 2345678901234567890123456789012345678901234567890<cr_lf>
<cr_lf>          ; interpreted as logical space
MOV              ; this ASM386<cr_lf>
& EAX,          ; statement extends<cr_lf>
&               ; <cr_lf>
&               ; <cr_lf>
&               ; over<cr_lf>
&               ; several lines<cr_lf>
& FOO           ; statement ends here<cr_lf>
<cr_lf>
```

# Assembler Statements

Assembler programs are constructed from statements. They may also contain definitions of and calls to programmer-defined macros. There are two kinds of statements: directives and instructions.

See also: Programmer-defined macros, Chapter 8

## Assembler Directives

Directive statements tell the assembler to perform certain operations. Assembler directives determine the organization of a program's data, stack, and code segments, and they affect almost every opcode that the assembler generates.

Table 1-1 lists the assembler directives by functional categories.

**Table 1-1. Assembler Directives**

| <b>Segmentation Directives</b>    |                                                                                                                                                                                                                        |
|-----------------------------------|------------------------------------------------------------------------------------------------------------------------------------------------------------------------------------------------------------------------|
| SEGMENT..ENDS                     | Defines a program's logical segments and specifies a code or data segment's attributes ( <i>access</i> protection, whether to <i>combine</i> with other logical segments, and whether to use 32- or 16-bit addressing) |
| STACKSEG                          | Defines stack segments and allocates a specified number of bytes per module to the run-time stack                                                                                                                      |
| ASSUME                            | Informs the assembler of the expected run-time contents of the processor segment registers                                                                                                                             |
| <b>Program Linkage Directives</b> |                                                                                                                                                                                                                        |
| NAME                              | Specifies a source module's unique name                                                                                                                                                                                |
| END                               | Required last statement in module that terminates assembly; in main module only, initializes CS and may also initialize DS and SS segment registers                                                                    |
| PUBLIC                            | Specifies that a named symbol is accessible from another program module                                                                                                                                                |
| EXTRN                             | Specifies that a named PUBLIC symbol in another program module can be accessed in this module                                                                                                                          |
| COMM                              | Specifies that a named symbol is to be allocated common and accessible data storage with COMM or EXTRN symbols in other program modules or specifies that a named PUBLIC symbol can be accessed in this module         |

continued

**Table 1-1. Assembler Directives (continued)**

| <b>Data Allocation and Type Definition Directives</b>    |                                                                                                                                                                |
|----------------------------------------------------------|----------------------------------------------------------------------------------------------------------------------------------------------------------------|
| DBIT                                                     | Allocates storage for and may initialize values of BIT-type variables                                                                                          |
| DB                                                       | Allocates storage for and may initialize values of BYTE-type variables                                                                                         |
| DW                                                       | Allocates (2 bytes) storage for and may initialize values of WORD-type variables                                                                               |
| DD                                                       | Allocates (4 bytes) storage for and may initialize values of DWORD- type variables                                                                             |
| DP                                                       | Allocates (6 bytes) storage for and may initialize values of PWORD- type variables                                                                             |
| DQ                                                       | Allocates (8 bytes) storage for and may initialize values of QWORD- type variables                                                                             |
| DT                                                       | Allocates (10 bytes) storage for and may initialize values of TBYTE- type variables                                                                            |
| <b>Data Allocation and Type Definition Directives</b>    |                                                                                                                                                                |
| RECORD                                                   | Names a programmer-defined type that is a bit-encoded data structure (1 to 4 bytes long)                                                                       |
| STRUC                                                    | Names a programmer-defined type with named fields; each field may be any of the predefined types                                                               |
| DUP                                                      | Allocates contiguous storage for a specified number of variables of a single type and may initialize their values                                              |
| <b>Procedure and Label Definition Directives</b>         |                                                                                                                                                                |
| <i>labelname:</i>                                        | Defines label within current code segment; assembler generates an intrasegment return of type NEAR                                                             |
| PROC..ENDP                                               | Defines labeled sequence of instructions (assembler generates an intrasegment return) of type NEAR or (assembler generates an intersegment return) of type FAR |
| LABEL                                                    | Defines label of a specified type (NEAR, FAR, or a declared variable's type)                                                                                   |
| <b>Location Counter Symbol and Management Directives</b> |                                                                                                                                                                |
| \$                                                       | Represents location counter (location of the statement currently being assembled)                                                                              |
| ORG                                                      | Sets \$ to specified value                                                                                                                                     |
| EVEN                                                     | Sets \$ for the following code or data to the next dword or word                                                                                               |
| ALIGN                                                    | Sets \$ to the next location for code or data that is evenly divisible by the specified number.                                                                |
| <b>Symbol Equating and Purging Directives</b>            |                                                                                                                                                                |
| EQU                                                      | Defines name (alias) for keyword reserved word, or program symbol                                                                                              |
| PURGE                                                    | Instructs assembler to delete specified symbol(s)                                                                                                              |

See also: Chapters 1 through 4 for more information about each directive in Table 1-1  
codemacro directives, Chapter 9

## Assembler Instructions

The assembler translates assembler instruction statements into opcodes, operands, and addresses. The machine code causes the processor and/or floating-point coprocessor to perform particular operations on (and with) the program's data. There are two kinds of assembler instructions: processor instructions and floating-point instructions. The floating-point instructions may be emulated on the processor or they may execute on a floating-point coprocessor.

Tables 1-2 and 1-3 list the assembler instructions by functional category. See Table 1-2 for the processor instruction set and Table 1-3 for the floating-point instruction set.

**Table 1-2. Processor Instructions**

| <b>Data Transfer Instructions</b>    |                                                                    |
|--------------------------------------|--------------------------------------------------------------------|
| MOV                                  | Move data                                                          |
| MOVZX                                | Move with zero extend                                              |
| MOVSX                                | Move with sign extend                                              |
| IN                                   | Input from port                                                    |
| OUT                                  | Output to port                                                     |
| XCHG                                 | Exchange register/memory with register                             |
| CMPXCHG                              | Compare and exchange (not available on Intel386 or 376 processors) |
| XLAT/XLATB                           | Table look-up translation                                          |
| <b>Address Transfer Instructions</b> |                                                                    |
| LEA                                  | Load effective address offset                                      |
| LDS                                  | Load full pointer into DS: <i>register</i>                         |
| LES                                  | Load full pointer into ES: <i>register</i>                         |
| LFS                                  | Load full pointer into FS: <i>register</i>                         |
| LGS                                  | Load full pointer into GS: <i>register</i>                         |
| LSS                                  | Load full pointer into SS: <i>register</i>                         |

continued

**Table 1-2. Processor Instructions (continued)**

|                           |                                                           |
|---------------------------|-----------------------------------------------------------|
| <b>Logic Instructions</b> |                                                           |
| NOT                       | One's complement negation                                 |
| AND                       | Logical AND                                               |
| OR                        | Logical (inclusive) OR                                    |
| XOR                       | Logical (exclusive) OR                                    |
| TEST                      | Logical compare (non-destructive AND)                     |
| CMP                       | Compare operands                                          |
| SHL                       | Shift logical left                                        |
| SHR                       | Shift logical right                                       |
| SAL                       | Shift arithmetic left                                     |
| SAR                       | Shift arithmetic right                                    |
| SHLD                      | Shift double precision left                               |
| SHRD                      | Shift double precision right                              |
| ROL                       | Rotate left                                               |
| ROR                       | Rotate right                                              |
| RCL                       | Rotate through carry flag (CF) left                       |
| RCR                       | Rotate through carry flag (CF) right                      |
| BSWAP                     | Byte swap (not available on Intel386 or 376 processors)   |
| <b>Stack Instructions</b> |                                                           |
| ENTER                     | Make stack frame for procedure's local variables          |
| LEAVE                     | High-level procedure exit                                 |
| PUSH                      | Push operand onto the stack                               |
| POP                       | Pop operand from the stack                                |
| PUSHFD/PUSHF              | Push EFLAGS or FLAGS register onto stack                  |
| POPF/POPF                 | Pop top of stack into EFLAGS or FLAGS register            |
| PUSHAD/PUSHA              | Push all (32- or 16-bit) general registers onto the stack |
| POPAD/POPA                | Pop stack into all (32- or 16-bit) general registers      |
| <b>Flag Instructions</b>  |                                                           |
| STC                       | Set carry flag (CF)                                       |
| CLC                       | Clear carry flag                                          |
| CMC                       | Complement carry flag                                     |
| STD                       | Set direction flag (DF)                                   |
| CLD                       | Clear direction flag                                      |
| STI                       | Set interrupt flag (IF)                                   |
| CLI                       | Clear interrupt flag                                      |
| LAHF                      | Load status flags into AH                                 |
| SAHF                      | Store AH into status flags                                |
| SETcc                     | Set byte on (status flag) condition                       |

continued

**Table 1-2. Processor Instructions (continued)**

|                                       |                                                                |
|---------------------------------------|----------------------------------------------------------------|
| <b>Mathematical Instructions</b>      |                                                                |
| ADC                                   | Add with carry                                                 |
| ADD                                   | Add                                                            |
| DEC                                   | Decrement by 1                                                 |
| DIV                                   | Unsigned divide                                                |
| IDIV                                  | Signed divide                                                  |
| IMUL                                  | Signed multiply                                                |
| INC                                   | Increment by 1                                                 |
| MUL                                   | Unsigned multiply                                              |
| NEG                                   | Two's complement negation                                      |
| SUB                                   | Integer subtraction                                            |
| XADD                                  | Exchange and add (not available on Intel386 or 376 processors) |
| <b>Data Adjustment Instructions</b>   |                                                                |
| AAA                                   | ASCII adjust AL after addition                                 |
| AAS                                   | ASCII adjust AL after subtraction                              |
| DAA                                   | Decimal adjust AL after addition                               |
| DAS                                   | Decimal adjust AL after subtraction                            |
| AAD                                   | ASCII adjust AX before division                                |
| AAM                                   | ASCII adjust AX after multiply                                 |
| AAD                                   | ASCII adjust AX before division                                |
| CBW                                   | Convert byte to word                                           |
| CWD                                   | Convert word to dword                                          |
| CWDE                                  | Convert word to dword extended                                 |
| CDQ                                   | Convert dword to quadword                                      |
| <b>String Instructions</b>            |                                                                |
| MOVS                                  | Move string to string                                          |
| CMPS                                  | Compare string operands                                        |
| SCAS                                  | Compare (scan) string data                                     |
| LODS                                  | Load string data                                               |
| STOS                                  | Store string data                                              |
| INS                                   | Input from port to string                                      |
| OUTS                                  | Output string to port                                          |
| <b>Bit Test and Scan Instructions</b> |                                                                |
| BT                                    | Bit test                                                       |
| BTS                                   | Bit test and set                                               |
| BTR                                   | Bit test and reset (to 0)                                      |
| BTC                                   | Bit test and complement                                        |
| BSF                                   | Bit scan forward                                               |
| BSR                                   | Bit scan reverse                                               |

continued

**Table 1-2. Processor Instructions (continued)**

|                                            |                                                                             |
|--------------------------------------------|-----------------------------------------------------------------------------|
| <b>Control Transfer Instructions</b>       |                                                                             |
| Jcc                                        | Jump if status flag condition is met                                        |
| JMP                                        | Jump unconditionally                                                        |
| CALL                                       | Call procedure                                                              |
| RET                                        | Return from procedure                                                       |
| LOOP                                       | Loop with (E)CX counter                                                     |
| LOOPcond                                   | Loop with (E)CX counter AND condition                                       |
| <b>Interrupt Instructions</b>              |                                                                             |
| INT                                        | Call to interrupt procedure                                                 |
| INTO                                       | Call to interrupt procedure if overflow                                     |
| IRET                                       | Interrupt return (16-bits)                                                  |
| IRETD                                      | Interrupt return (32-bits)                                                  |
| <b>Processor Control</b>                   |                                                                             |
| HLT                                        | Halt                                                                        |
| WAIT                                       | Wait until BUSY# is inactive                                                |
| <b>Protected Mode Control Instructions</b> |                                                                             |
| LGDT/LGDTW/LGDTD                           | Load global descriptor table register (GDTR) using 16- or 32-bit operand    |
| LIDT/LIDTW/LIDTD                           | Load interrupt descriptor table register (IDTR) using 16- or 32-bit operand |
| LLDT                                       | Load local descriptor table (LDT) register (LDTR)                           |
| LTR                                        | Load task register (TR)                                                     |
| LMSW                                       | Load machine status word (MSW)                                              |
| SGDT/SGDTW/SGDTD                           | Store GDTR using 16- or 32-bit operand                                      |
| SIDT/SIDTW/SIDTD                           | Store IDTR using 16- or 32-bit operand                                      |
| SLDT                                       | Store local descriptor table register                                       |
| STR                                        | Store task register                                                         |
| SMSW                                       | Store machine status word                                                   |
| ARPL                                       | Adjust requesting privilege level (RPL) field of selector                   |
| CLTS                                       | Clear task switch (TS) flag in CR0 register                                 |
| <b>Parameter Verification Instructions</b> |                                                                             |
| BOUND                                      | Check array index against bounds                                            |
| LAR                                        | Load access rights                                                          |
| LSL                                        | Load segment limit                                                          |
| VERR                                       | Verify a segment for reading                                                |
| VERW                                       | Verify a segment for writing                                                |

continued

**Table 1-2. Processor Instructions (continued)**

|                                   |                                                                                    |
|-----------------------------------|------------------------------------------------------------------------------------|
| <b>Cache Control Instructions</b> |                                                                                    |
| INVLPG                            | Invalidate paging cache entry (not available on Intel386 or 376 processors)        |
| INVD                              | Invalidate data cache (not available on Intel386 or 376 processors)                |
| WBINVD                            | Write back and invalidate data cache (not available on Intel386 or 376 processors) |
| <b>No Operation Instruction</b>   |                                                                                    |
| NOP                               | No operation (fills 1 byte and increments instruction pointer)                     |
| <b>Instruction Prefixes</b>       |                                                                                    |
| LOCK                              | Assert BUS LOCK# signal prefix                                                     |
| REP                               | Repeat following string operation                                                  |

See also: Chapter 6 for an overview of the processor instruction set and for detailed information about each processor instruction

**Table 1-3. Floating-point Instructions**

| <b>Data Transfer Instructions</b>          |                                                                                                            |
|--------------------------------------------|------------------------------------------------------------------------------------------------------------|
| FLD                                        | Load real                                                                                                  |
| FST                                        | Store real                                                                                                 |
| FSTP                                       | Store real and pop floating-point stack                                                                    |
| FXCH                                       | Exchange stack elements                                                                                    |
| FILD                                       | Load integer                                                                                               |
| FIST                                       | Store integer                                                                                              |
| FISTP                                      | Store integer and pop floating-point stack                                                                 |
| FBLD                                       | Load packed decimal real                                                                                   |
| FBSTP                                      | Store packed decimal real                                                                                  |
| <b>Load Internal Constant Instructions</b> |                                                                                                            |
| FLDZ                                       | Load +0.0                                                                                                  |
| FLD1                                       | Load 1.0                                                                                                   |
| FLDPI                                      | Load $\pi$                                                                                                 |
| FLDL2T                                     | Load $\log_2 10$                                                                                           |
| FLDL2E                                     | Load $\log_2 e$                                                                                            |
| FLDLG2                                     | Load $\log_{10} 2$                                                                                         |
| FLDLN2                                     | Load $\log_e 2$                                                                                            |
| <b>Comparison Instructions</b>             |                                                                                                            |
| FCOM                                       | Compare real                                                                                               |
| FCOMP                                      | Compare real and pop floating-point stack                                                                  |
| FCOMPP                                     | Compare real and pop twice                                                                                 |
| FUCOM                                      | Unordered compare real (not available on Intel287 floating-point coprocessor)                              |
| FUCOMP                                     | Unordered compare real and pop floating-point stack (not available on Intel287 floating-point coprocessor) |
| FUCOMPP                                    | Unordered compare real and pop twice (not available on Intel287 floating-point coprocessor)                |
| FICOM                                      | Compare integer                                                                                            |
| FICOMP                                     | Compare integer and pop floating-point stack                                                               |
| FTST                                       | Test (compare to zero)                                                                                     |
| FXAM                                       | Examine                                                                                                    |

continued

**Table 1-3. Floating-point Instructions (continued)**

|                                    |                                                                                       |
|------------------------------------|---------------------------------------------------------------------------------------|
| <b>Transcendental Instructions</b> |                                                                                       |
| FSIN                               | Sine (not available on Intel287 floating-point coprocessor)                           |
| FCOS                               | Cosine (not available on Intel287 floating-point coprocessor)                         |
| FSINCOS                            | Sine and cosine (not available on Intel287 floating-point coprocessor)                |
| FPTAN                              | Partial tangent                                                                       |
| FPATAN                             | Partial arctangent                                                                    |
| F2XM1                              | $2^x - 1$                                                                             |
| FYL2X                              | $Y * \log^2 X$                                                                        |
| FYL2XP1                            | $Y * \log^2 (X + 1)$                                                                  |
| <b>Algebraic Instructions</b>      |                                                                                       |
| FADD                               | Add real                                                                              |
| FADDP                              | Add real and pop floating-point stack                                                 |
| FIADD                              | Add integer                                                                           |
| FSUB                               | Subtract real                                                                         |
| FSUBP                              | Subtract real and pop floating-point stack                                            |
| FSUBR                              | Subtract real reversed                                                                |
| FSUBRP                             | Subtract real reversed and pop floating-point stack                                   |
| FISUB                              | Subtract integer                                                                      |
| FISUBR                             | Subtract integer reversed                                                             |
| FMUL                               | Multiply real                                                                         |
| FMULP                              | Multiply real and pop                                                                 |
| FIMUL                              | Multiply integer                                                                      |
| FDIV                               | Divide real                                                                           |
| <b>Algebraic Instructions</b>      |                                                                                       |
| FDIVP                              | Divide real and pop floating-point stack                                              |
| FDIVR                              | Divide real reversed                                                                  |
| FDIVRP                             | Divide real reversed and pop floating-point stack                                     |
| FIDIV                              | Divide integer                                                                        |
| FIDIVR                             | Divide integer reversed                                                               |
| FSQRT                              | Square root                                                                           |
| FSCALE                             | Scale                                                                                 |
| FPREM                              | Partial remainder                                                                     |
| FPREM1                             | IEEE std.754 partial remainder (not available on Intel287 floating-point coprocessor) |
| FRNDINT                            | Round real to integer                                                                 |
| EXTRACT                            | Extract exponent and significand                                                      |
| FABS                               | Absolute value                                                                        |
| FCHS                               | Change sign                                                                           |

continued

**Table 1-3. Floating-point Instructions (continued)**

| <b>Processor Control Instructions</b> |                                                  |
|---------------------------------------|--------------------------------------------------|
| FINIT/FNINIT                          | Initialize floating-point coprocessor            |
| FSTCW/FNSTCW                          | Store control word                               |
| FLDCW                                 | Load control word                                |
| FSTSW/FNSTSW                          | Store status word                                |
| FCLEX/FNCLEX                          | Clear exceptions                                 |
| FSTENV/FNSTENV                        | Store environment                                |
| FLDENV                                | Load environment                                 |
| FSAVE/FNSAVE                          | Store machine state                              |
| FRSTOR                                | Restore machine state                            |
| FINCSTP                               | Increment floating-point stack pointer           |
| FDECSTP                               | Decrement floating-point stack pointer           |
| FFREE                                 | Free (empty) stack top element                   |
| FNOP                                  | No operation                                     |
| FSETPM                                | Set (Intel287) protected mode (Otherwise FNOP)   |
| FWAIT                                 | Wait (alternate specification of processor WAIT) |

See also: Chapter 7 for detailed information about each assembler floating-point instruction

## Specifying Assembler Statements

The general syntax for assembler directive statements is similar to that for instructions.

### Specifying Directive Statements

Assembler directive statements have the following general syntax:

```
[name] directive [argument [, ...]]
```

Where:

*name* is a valid identifier.

*directive* is one of the directives listed in Table 1-1.

*argument* is a modifier or value to be associated with *name*.

Each assembler directive has its own set and/or forms of argument(s). Some directives have no valid arguments in the context of a program. Some have a restricted set of arguments that are reserved words. Others accept constant values and constant expressions.

See also: Chapters 2 through 4 for more detailed information about each directive in Table 1-1

## Specifying Instruction Statements

Assembler instruction statements have the following general syntax:

```
[label:] [prefix]mnemonic[argument[, ...]]
```

Where:

*label* is a unique-to-the-module identifier that defines a label.

*prefix* is a processor instruction prefix (LOCK or REP).

*mnemonic* is a processor or floating-point instruction (listed in Table 1-2 or 1-3) or it is a programmer-defined codemacro.

*argument* is an operand.

Some instructions have no operands; others require one, two, or three operands. Some operands may be expressions. The general form of an instruction with operands is one of the following:

```
mnemonic src
```

where the execution result may be stored either in the source itself (*src*) or in an implicit location (usually a register or the floating-point stack top element ST).

```
mnemonic dest, src
```

where the execution result is stored either in the destination (*dest*) or in an implicit location; the instruction's operation does not change the source operand.

Only a few processor instructions have three operands. For floating-point instructions, one operand is usually the stack top ST(0).

See also: Programmer-defined codemacros, Chapter 9  
expressions, Chapter 5  
instruction operands, Chapter 6 (Table 1-2) and Chapter 7 (Table 1-3)

# Assembler Program Structure

Figure 1-1 illustrates the essential parts of an assembler program that is contained in a single source module and intended to run in processor protected mode.

Figure 1-2 illustrates such an example program.

The following subsections explain what each assembler statement in Figure 1-1 does.

```
    ; This is a comment. Tokens in bold face can seldom
    ; be omitted from any non-trivial assembler program.
    ; Those in type like THIS are strongly recommended for
    ; every assembler
    ; program and some are required by all but the simplest.
NAME MAIN_MODULE
    ; MAIN_MODULE is programmer defined for this module.
PROG_STACK STACKSEG 500
    ; PROG_STACK is programmer defined for program's stack
    ; segment and 500 is number of bytes in segment.
PROG_DATA SEGMENT RW
    ; PROG_DATA is programmer defined for program's data
    ; segment and RW (read/write) is this segment's
    ; access attribute (ReadOnly or ExecuteRead also possible).
    ; Program data must be defined and may be initialized here
PROG_DATA ENDS
PROG_CODE SEGMENT ER
    ; PROG_CODE is programmer defined for program's code
    ; segment and ER (execute/read) is this segment's
    ; access attribute (ExecuteOnly also possible).
ASSUME DS:PROG_DATA
    ; Tells assembler which processor segment register
    ; points to program's data segment for the following
MAIN:
    ; code. MAIN is programmer defined label specifying
    ; program entry point (execution begins here). Assembler
    ; instruction statements begin at label (MAIN) and must
    ; be coded between SEGMENT..ENDS. DS, SS, ES, FS and GS
    ; segment register initializations may be coded here too.
PROG_CODE ENDS                                ; Code segment ends.
END CS:MAIN, DS:PROG_DATA, SS:PROG_STACK
```

**Figure 1-1. Template for an Assembler Program**

## NAME Directive

Assembler programs with more than one source module must specify a unique name for each module. The assembler will assign the module identifier ANONYMOUS if the NAME statement is omitted. A multi-module program cannot be combined and located by the system utilities if two modules have the same name.

See also: NAME directive, Chapter 3

```
NAME TOY_MAIN_MODULE

PROG_STACK STACKSEG 200

EXTRN EXIT: FAR

PROG_DATA SEGMENT RW

    VAR1 DB 0
    VAR2 DD 0
    VAR3 DD 1000

PROG_DATA ENDS

PROG_CODE SEGMENT ER USE32

ASSUME DS: PROG_DATA

MAIN:    INC VAR1                ; increment counter
        PUSH EAX                ; store EAX on stack
        MOV EAX, VAR2           ; move VAR2 value to EAX
        ADD EAX, 500
        MOV VAR2, EAX           ; store sum in VAR2
        POP EAX                 ; restore original EAX value
        ; from stack
        MOV ECX, VAR3           ; move VAR3 to ECX
        SUB ECX, VAR2           ; subtract 500
        ; from 1000 in ECX
        JNZ MAIN                ; jump to MAIN if subtraction
        ; result in ECX not zero and
        ; end loop when result = 0

        CALL EXIT

PROG_CODE ENDS

END MAIN, DS:PROG_DATA, SS:PROG_STACK
```

**Figure 1-2. An ASM386 Example Program**

## STACKSEG Directive

Any assembler program that allocates data dynamically on a stack should define a named stack segment with a `STACKSEG` statement.

In assembler programs, source modules share a single stack segment. `STACKSEG` must be specified with the same name in each source module that references data on the stack. In such a source module, the `STACKSEG` statement specifies the number of bytes that the module will allocate on the to-be-combined stack segment for the whole program.

For stack segments, the assembler determines the use attribute. A stack segment's use attribute determines the upper limit for offsets within the segment; it also determines whether the ESP or SP register is used for implicit stack references.

See also: `STACKSEG` directive, Chapter 2  
processor stack architecture, Appendix A

## SEGMENT Directive for Data Segments

Assembler data must be defined within a `SEGMENT . . ENDS`. This directive specifies at least a name for one program (or module) data segment; it may also specify access, use, and combine attributes for the named data segment.

Assembler source modules may define any number of named data segments with `SEGMENT . . ENDS`. The processor DS (default), ES, FS, and GS segment registers provide access to data segments. At most four named data segments are accessible at any given point in a module.

Each data segment within a module must have a distinct name. The assembler assigns the RW (read/write access) attribute unless RO or ER is specified for the segment.

The assembler assigns the `USE32` (use 32-bit addressing) attribute for the whole module by default unless `USE16` is specified as an assembler control. Segments within the module may have individually specified `USE` attributes. When a `USE` attribute is defined on a segment, it remains in effect throughout that segment. For all segments, the `USE` attribute determines the maximum segment size: 4 gigabytes ( $2^{32} - 1$ ) for `USE32` and 64K bytes ( $2^{16} - 1$ ) for `USE16`.

Named data segments may be shared across program source modules only if a `PUBLIC` or `COMMON` combine attribute is specified in the `SEGMENT` statement. Each data segment that is shared among modules must have the same name with the same use and combine attributes and compatible access attributes.

See also: Processor registers, memory organization, and access protection features, Appendix A  
`SEGMENT` directive, Chapter 2  
defining shared data entities inside the `SEGMENT . . ENDS` of multiple source modules, Chapter 3  
defining data (variables, labels, and constants) and specifying assembler data values within `SEGMENT . . ENDS`, Chapter 4

## SEGMENT Directive for the Code Segment

All assembler instruction statements must be specified within `SEGMENT . . ENDS`. This directive specifies at least a name for the module's code segment. It may also specify access, use, and combine attributes for the code segment.

The assembler assigns `ER` (execute/read) access unless `EO` (execute only) is specified for the segment. The assembler assigns `USE32` (use 32-bit addressing) for the whole module by default unless `USE16` is specified as an assembler control. When a `USE` attribute is defined on a segment, it remains in effect throughout that segment.

The `USE` attribute of a segment instructs the assembler to generate 32- or 16-bit (offset) addresses and default lengths for instruction operands. It also determines the segment's maximum size: 4 gigabytes ( $2^{32} - 1$ ) for `USE32` and 64K bytes ( $2^{16} - 1$ ) for `USE16`.

Code segments defined with the same name and specified with the `PUBLIC` combine attribute are concatenated into a single code segment. If `PUBLIC` is not specified for a module's code segment, it is non-combinable and must be wholly contained in a single source module.

The code segment of a program's main module must have a label (`MAIN:` in Figures 1-1 and 1-2) at the first executable instruction of the program. The main module's `END` statement must specify this label.

See also: `END` statement, `END` Directive, in this chapter  
Assembler Statements for a summary of the assembler instructions and directives  
`SEGMENT . . ENDS` directive, including the `PUBLIC` combine attribute, Chapter 2  
accessing data with address expressions, Chapter 5  
Chapters 6 and 7 for detailed information about each assembler instruction

## ASSUME Directive

If no `ASSUME` statement is specified in an ASM386 code segment, the assembler assumes that `CS` contains the selector of the code segment but that no other segment register has been loaded. The assembler cannot generate a correct logical address for a symbolic reference unless it knows which segment register contains the selector for the symbol's defining segment. The assembler must know the correct segment register whenever an instruction statement references memory data. Such references include:

- Symbolic references using the name of a variable, label, or constant as an operand to an instruction (e.g., `ADD EAX, VAR2`)
- Non-symbolic references using segment overrides and the `PTR` operator (e.g., `ADD EAX, GS:DWORD PTR 24`)

Initialize a segment register for each memory segment that is referenced in your code and specify `ASSUME` at each point in the source code where the run-time contents of a segment register will change for subsequent instructions.

See also: Initializing Segment Registers with Instructions, in this chapter  
`ASSUME` directive, Chapter 2  
processor segment registers, Appendix A

## END Directive

The `END` statement terminates assembly; it must be the last statement in an ASM386 source module.

The main module's `END` statement must specify at least the code segment's entry point label in order to initialize the CS and (E)IP registers. When the program is loaded, CS:(E)IP points to the entry point label of the code segment. EIP (32-bit addressing) or IP (16-bit addressing) also points to the (labeled) instruction.

The SS and DS segment registers may also be initialized with the main module's `END` statement. If they are, when the program is loaded:

- SS contains the selector for the stack segment. ESP (32-bits) or SP (16-bits) contains the offset of the first dword (32-bits) or word (16-bits) above the upper segment limit if the stack segment was defined with `STACKSEG`; (E)SP has a value equal to the size of the stack plus 4 (for ESP) or plus 2 (for SP). (E)SP is 0 if the stack segment was not defined with `STACKSEG`.
- DS contains the selector for the data segment.

Note that an explicit `MOV` reference to the data segment name is not required to initialize DS to the data segment (see Figure 1-2) when DS is initialized by the `END` statement.

The ES, FS, and GS data segment registers cannot be initialized with the main module's `END` statement. In non-main modules, segment registers may not be initialized with the `END` statement.

See also: `END` statement, Chapter 3

## Initializing Segment Registers with Instructions

Memory data must be accessible if assembler instructions are to operate on it. If all program modules have a single, shared data segment, specifying `ASSUME DS:datasegname` and initializing DS with the main module's `END` statement provides the necessary access. Even one-module programs that define more than one named data segment must initialize the ES, FS, or GS register(s) explicitly in the code segment.

Since each assembler module may define several data segments, individual modules of a program may have local, as well as shared data segments. But, as the program executes, only four data segment registers are available to access memory data. Thus, the DS, ES, FS, and GS register contents may change within a module and from module to module. In these cases, specify an `ASSUME` statement and initialize the data segment register(s) before an instruction accesses memory data.

A module's stack segment may also be initialized explicitly in the code segment, rather than with the (main) module's `END` statement.

## Initializing DS, ES, FS, and GS

The DS, ES, FS, and GS registers may be initialized in four ways in a source module's code segment:

1. By specifying sequential `MOV` instructions using the data segment name:
  - The first `MOV` has a destination operand that is a general register (AX, BX, CX, DX, SI, DI, SP, BP) and a source operand that is the name of a data segment in the module. Avoid specifying SP or BP if the module accesses the stack segment.
  - The next `MOV` has a destination operand that is a data segment register (DS, ES, FS, or GS) and a source operand that is the destination register specified in the preceding `MOV`.
2. By specifying sequential `MOV` instructions and using the `SEG` operator:
  - The first `MOV` has a destination operand that is a general register (AX, BX, CX, DX, SI, DI, SP, BP) and a source operand that is a symbol (named variable, label, or constant) preceded by `SEG`. The `SEG` expression represents the segment base address of the symbol's defining data segment. Avoid specifying SP or BP if the module accesses the stack segment.  
  
See also: `SEG`, Chapter 5
  - The next `MOV` has a destination operand that is a data segment register (DS, ES, FS, or GS) and a source operand that is the destination register specified in the preceding `MOV`.
3. By specifying a `MOV` instruction with DS, ES, FS, or GS as the destination operand and an initialized memory location as the source operand.
4. By specifying an `LDS`, `LES`, `LFS`, or `LGS` instruction with a memory operand that is a pointer. Do not attempt to load a segment register directly by using a segment name as a source operand; a segment name is an immediate operand, not a memory operand.

## Examples

1. This example initializes ES. ES will contain the selector of the DATA2 segment after both MOV statements execute.

```
DATA1 SEGMENT RW
    : : ; its data accessed
DATA1 ENDS ; by DS:EAX later
DATA2 SEGMENT RW
    VAR32 DD 0
DATA2 ENDS
    : : ; more segment definitions
MOV BX, DATA2
ASSUME ES:DATA2
MOV ES, BX
```

2. This example initializes FS. FS will contain the selector of VAR32's defining data segment after both MOV statements execute. The EXTRN directive indicates that VAR32 is defined in another source module.

See also: EXTRN, Chapter 3

```
    : :
EXTRN VAR32 DWORD
    : :
    : :
MOV CX, SEG VAR32
ASSUME FS:SEG VAR32
MOV FS, CX
```

## Initializing SS

The SS (stack segment) register and (E)SP may also be initialized in the code segment:

1. By specifying sequential instructions, just as for a data segment with SS as the destination segment register.
2. By specifying (E)SP as a MOV destination operand and the stack segment name as the source operand preceded by the STACKSTART operator.
3. By specifying the LSS instruction with a memory operand that is a pointer. Do not attempt to load a segment register directly by using a segment name as a source operand; a segment name is an immediate operand, not a memory operand.

(E)SP points to the top of the processor push-down stack. This register is referenced implicitly by the processor `ENTER`, `LEAVE`, `PUSH`, `POP`, `PUSHA`, `POPA`, `PUSHF`, `POPF`, `CALL` and interrupt operations. (E)BP should be used as the stack-frame base pointer to avoid having to specify SS explicitly for each data access within a stack frame.

## Example

This example uses `STACKSTART` to initialize (E)SP. A `MOV` into SS disables interrupts for one instruction so that (E)SP can be initialized. After these instructions execute, (E)SP points to the (d)word above the upper stack segment limit.

```
MOV AX, PROG_STACK
MOV SS, AX
MOV ESP, STACKSTART PROG_STACK
```

See also: `STACKSTART`, Chapter 5



# Segmentation 2

---

This chapter contains three major sections:

- Overview of Segmentation

This section briefly describes processor segmentation, together with the assembler directives that define and set up access to logical program segments.

- Defining Logical Segments

This section explains the `SEGMENT . . ENDS` and `STACKSEG` directives. These directives define code, data, and stack segments in assembler programs.

- Assuming Segment Access

This section explains the `ASSUME` directive. This directive specifies which segments in an assembler program are accessed by the processor segment registers at any given point in the program's code.

## Overview of Segmentation

The processor addresses 4 gigabytes of physical memory. Processor memory is segmented. For programmers, processor memory appears to consist of up to six accessible segments at a time:

- One code segment containing the executable instructions
- One stack segment containing the run-time stack
- Up to four data segments, each containing part of the data

Assembler program segments are called logical segments, because they represent logical addresses that must be mapped to processor physical addresses before program execution.

The maximum size of a program segment depends on which `USE` attribute is specified in the source. When `USE32` is specified, the maximum size for a segment is 4 gigabytes. When `USE16` is specified, it is 64K bytes.

See also: Processor memory organization, Appendix A  
operand addressing and the `USE` attribute, Chapters 5 and 6

At run time, the physical base address of a program segment will be accessed by an immediate value loaded into a segment register. This value is called a selector. A selector points (indirectly in processor protected mode and directly in processor real address mode) to the physical location of a segment. The processor segment registers are CS, DS, and SS, which access code, data, and stack segments, respectively, and ES, FS, and GS, which access additional data segments.

Logical segments are created in an assembler module with the `SEGMENT` (code and data) and `STACKSEG` (stack or stack-and-data) directives. These directives specify a segment name; this name defines a logical address for the segment. A segment name can appear in several contexts throughout a program:

- In data initializations, because it stands for the value of the selector
- In segment register initializations
- In an `ASSUME` statement, which tells the assembler which segment registers contain which selectors

See also: `ASSUME` statement, in this chapter  
selectors, Chapter 4  
data and segment register initializations, Chapter 1

After program code is assembled, the system utilities map assembler program segments to processor physical addresses. A named segment becomes a sequence of contiguous physical addresses. A logical segment becomes physically accessible when the segment name is loaded into a processor segment register during program execution.

# Defining Code, Data, and Stack Segments

The `SEGMENT . .ENDS` directive defines an assembler program's code and data segments. The `STACKSEG` directive defines the stack (or mixed stack and data) segment. Both directives specify a name for each logical segment defined in a program.

Because program segments are named, assembler logical segments need not be contiguous lines of source code. Within a source module, a named segment can be closed with `ENDS` and reopened with another `SEGMENT . .` that specifies the same name. Logical segments can also be coded in more than one source module.

See also: Logical segments in source modules, Chapter 3

## SEGMENT..ENDS Directive

### Syntax

```
name SEGMENT [access] [use] [combine]  
      :      :  
      [instructions, directives, and/or data initializations]  
      :      :  
name ENDS
```

Where:

*name* is an identifier for the segment; *name* must be unique within the module. *name* represents the logical address of the beginning of the program segment. The segment's contents (specified between `SEGMENT . .ENDS`) represent logical addresses that are offsets from the segment *name*.

*access* is an optional RO (read only), EO (execute only), ER (execute and read), RW (read and write).

*use* is `USE32` or `USE16`. If *use* is not specified explicitly in the `SEGMENT` statement, the segment's `USE` attribute defaults to that of its nearest enclosing segment or to that of the module. The overall default for program modules is `USE32`.

*combine* is unspecified (default), `PUBLIC`, or `COMMON`. If neither `PUBLIC` nor `COMMON` is specified for *name*, the segment is non-combinable: the entire segment is in this module and it will not be combined with segments of the same *name* from any other module. However, separate pieces of a non-combinable segment within a module will be combined.

If a `SEGMENT PUBLIC` or `SEGMENT COMMON` directive has been specified for the segment *name*, the *combine* specification for segments with the same name in other modules must be the same.

## Discussion

The `SEGMENT . . ENDS` directive defines all or part of a logical program segment whose name is *name*. The contents of the segment consist of the assembled instructions, directives, label declarations, and/or data initializations that occur between `SEGMENT` and `ENDS`. These contents will be mapped to a contiguous sequence of processor physical addresses by the system utilities. When a segment name is used as an instruction operand, it is an immediate value.

Within a single source module, each occurrence of `SEGMENT . . ENDS` that has the same name is considered part of a single program segment. All ASM386 source code must be specified within a `SEGMENT . . ENDS`. Every named variable and label in an assembler program must also be defined within a `SEGMENT . . ENDS`.

*Access*, *use*, and *combine* are optional; they may be specified in any order.

## Specifying EO, ER, RO, or RW Access

*access* is an assembler (and processor) protection feature; it specifies the kind(s) of access permitted to the segment.

The assembler issues a warning for the initial definition of a segment if the *access* specification is omitted. The assembler also assigns an *access* value according to the contents of the segment. For a segment that contains data only, the value is RW; for a segment that contains code only, it is EO. For mixed code and data, the value is ER.

After a named segment has been defined with a `SEGMENT` statement, access can be omitted when the segment is reopened. However, its value may not be changed when the segment is reopened.

## Specifying USE32 or USE16

*use* specifies the segment's `USE` attribute, which determines the addressing mode, maximum segment size, and operand size for code within the segment.

If *use* is not specified in the `SEGMENT` statement, the segment's `USE` attribute defaults to that of its nearest containing segment or to that of the module. The `USE` attribute of a module may be specified as an assembler operating control when the assembler is invoked. The overall default for assembler program modules is `USE32`.

`USE32` causes 32-bit offsets to be generated for identifiers (variables, labels, structures, records, and procedure names) defined within the segment. `USE32` segments can be up to 4 gigabytes long.

USE16 causes 16-bit address offsets to be generated for identifiers defined within the segment. USE16 segments can be up to 64K bytes long.

The USE attribute of the segment also determines operand sizes for certain processor instructions. For example, if the segment is USE32, the ENTER instruction will assume that the required immediate operand is 32-bits; if the segment is USE16, the operand will be zero-extended to 32-bits.

See also: USE attribute, *ASM386 Macro Assembler Operating Instructions* USE32, Chapter 4  
address and operand sizes, Chapter 6

## Specifying PUBLIC or COMMON

*combine* specifies how the segment will be combined with segments of the same name from other modules to form a single physical segment in memory. The actual combination of modules occurs at bind time.

If a SEGMENT directive specifying PUBLIC or COMMON already exists for a named segment, *combine* specifications in other modules must match it. The named segment's *combine* attribute should be specified (at least) for the initial segment definition in subsequent modules. The following explains how a logical segment in more than one module is combined:

- All segments of the same name that are defined as PUBLIC will be concatenated to form one physical segment. Control the order of combination with the binder.

The length of the combined PUBLIC segment will equal approximately the sum of the lengths of the SEGMENT . . ENDS pieces. For a segment declared PUBLIC, there is no guarantee that the beginning of a particular segment part within the module will have an offset of zero within the final combined segment.

- All segments of the same name that are defined as COMMON will be overlapped to form one physical segment. Each module's version of the segment begins at offset zero within the segment, so each version has the same physical address.

The length of the combined COMMON segment will be equal to the longest individual length within any of its defining modules. A COMMON segment may not specify EO or ER access.

If neither PUBLIC nor COMMON is specified, the segment is non-combinable. The entire logical segment must be contained in a single source module. It cannot be combined with segments from other program modules.

## Multiple Definitions for a Segment

Assembler segments can be opened and closed (with the `SEGMENT . .ENDS` directive) within a source module as many times as you wish. All separately defined parts of the segment are concatenated by the assembler and treated as if they were defined within a single `SEGMENT . .ENDS`.

Assembler procedure, codemacro, and structure definitions may not overlap segment boundaries.

When a segment is reopened, it is unnecessary to respecify its *access*, *use*, and *combine* attributes, if any. Do not change the *combine* or *use* attribute when a segment is reopened.

If a segment's access is respecified, both access specifications must form a compatible set. The following are compatible sets:

- RO and RW are a compatible set with a resulting access attribute of RW.
- Any combination of RO, EO, and ER form a compatible set with a resulting access attribute of ER.

There are no other compatible sets for *access* specifications.

## Examples

1. This example reopens the segment named `DATA`.

```
DATA SEGMENT
  ABYTE DB 0
  AWORD DW 0
DATA ENDS
: :
; any number of other segments not named DATA
: :
DATA SEGMENT
  ANOTHERBYTE DB 0
  ANOTHERWORD DW 0
DATA ENDS
```

2. This example is an equivalent to the preceding example as a segment definition for DATA.

```
DATA SEGMENT
  ABYTE DB 0
  AWORD DW 0
  ANOTHERBYTE DB 0
  ANOTHERWORD DW 0
DATA ENDS
```

3. This example defines a PUBLIC segment with ER access.

```
CODE SEGMENT RO PUBLIC USE32
  :
CODE ENDS
  :
CODE SEGMENT EO
  : ; implied PUBLIC
  : ; and USE32 from above
  :
CODE ENDS
```

4. This example has an **error** because RW and ER are not compatible access specifications.

```
FOO SEGMENT RW
  :
FOO ENDS
  :
FOO SEGMENT ER ; error:
  : ; RW and ER are not compatible
  :
FOO ENDS
```

5. This example has **errors** because it changes combine and use attributes when a segment is reopened.

```
DATA SEGMENT RW COMMON USE16
  :
DATA ENDS
  :
DATA SEGMENT RW PUBLIC USE32
  : ; errors:
  : ; cannot change combine
  : ; or USE attribute
  :
DATA ENDS
```

## Lexically Nested or Embedded Segment Definitions

Assembler segments are never nested or embedded physically in processor memory. For convenience, segment definitions may be nested in a program. This is a lexical nesting; it does not represent a physical nesting. However, care must be taken to close lexically nested segments inside their containing segment(s).

### Examples

1. This example illustrates a nested segment definition that is a legal assembler construct. The assembler considers the code segment to be separate from the data segment. The contents of the data segment are not contained within the code segment (their physical addresses on the processor might be far apart in memory after binding).

```
PROG_CODE SEGMENT
: : ; begin PROG_CODE
: :
  PROG_DATA SEGMENT
: : ; begin PROG_DATA
: : ; stop assembling PROG_CODE
: :
  PROG_DATA ENDS
: : ; stop PROG_DATA
: : ; start PROG_CODE again
: :
PROG_CODE ENDS ; end PROG_CODE
```

2. This code will cause an **error**. For lexically nested segment definitions, `SEGMENT . . ENDS` pairs must be matched as shown in the preceding example.

```
PROG_CODE SEGMENT ; begin PROG_CODE
: :
  PROG_DATA SEGMENT ; begin PROG_DATA
: :
PROG_CODE ENDS ; error:
: : ; cannot close PROG_CODE
: : ; before closing
: : ; PROG_DATA
: :
PROG_DATA ENDS
```

# STACKSEG Directive

## Syntax

```
name STACKSEG exp
```

Where:

*name* is an identifier for the stack segment; *name* must be unique within the program.

*exp* is this declaration's contribution to the size (number of bytes) of the segment. *exp* must evaluate to a constant between 0 and 4 gigabytes ( $2^{32} - 1$ ) for USE32 segments, and between 0 and 64K bytes (65,535) for USE16 segments.

## Discussion

The STACKSEG directive is used to allocate *exp* bytes for a stack segment named *name*. The STACKSEG directive both opens and closes the segment. Do not close STACKSEG with ENDS.

Assembler stack segments always have RW access and PUBLIC combine attributes. Multiple definitions of a stack segment with the same name will result in one segment whose size is the sum of all specified sizes.

A stack segment is not explicitly assigned a use attribute of USE32 or USE16. A stack segment's use attribute is either the same as:

- The nearest enclosing segment's use attribute, if any
- Or, the module's use attribute

Most single-task applications have only one stack segment. Code, labels, variables, or data initializations cannot be defined within a stack segment. The STACKSTART operator or the END directive may be used to initialize the stack pointer (contents of SS:(E)SP).

See also: Code, labels, variables, and data initializations, Chapter 4  
STACKSTART operator, Chapter 5  
END directive, Chapter 3

## Combining Stack and Data Segments

If a data and a stack segment are given the same name, they are combined into a single data/stack combined (dsc) segment if they have compatible attributes.

Such a segment has both a stack part and a data part. Its data segment must be declared `PUBLIC` with `RO` or `RW` access. If the declared access is `RO`, the combined access is `RW`.

It is an error if the data segment is not `PUBLIC` (or if it has `EO` or `ER` access). The stack and data segments will not be combined in this case. Instead, the assembler will append `_STACK` to the name of the stack segment to keep each segment distinct.

## Assuming Segment Access

The `ASSUME` directive may not be omitted from assembler programs that reference symbols (named variables and labels) unless segment overrides are specified for every symbolic reference. The `ASSUME` directive may not be omitted from programs with non-symbolic memory references such as `ES:WORD PTR 2`.

The `ASSUME` directive tells the assembler which processor segment register points to a particular logical segment in the program so that it generates code for instruction operands that are named variables and labels in memory. However, `ASSUME` does not load a segment register.

If no `ASSUME` statement is specified in a code segment, the assembler assumes that `CS` contains the selector of the code segment but that no other segment register has been loaded. The assembler cannot generate a correct logical address for a symbolic reference unless it knows which segment register contains the selector for the symbol's defining segment.

The processor cannot access symbolic memory data unless the segment registers have been correctly loaded. Whenever you load a new selector into a segment register, specify an `ASSUME` if subsequently coded instructions will reference memory data via that segment register.

See also:     Segment overrides, Chapter 5  
              segment registers, Chapter 1

# ASSUME Directive

## Syntax

```
ASSUME Sreg:segspart [,...]
ASSUME Sreg:NOTHING [,...]
```

or

```
ASSUME NOTHING
```

Where:

*Sreg* is one of the registers DS, ES, FS, GS, or SS; *Sreg* may be CS only if NOTHING is specified.

*segs*part is the reserved word NOTHING, the name of a segment, or one of the following forms:

```
SEG varname
SEG labelname
SEG externalname
```

The name of a segment indicates that *Sreg* contains the segment selector for variables and labels defined in the segment.

SEG *varname*, *labelname*, or *externalname* indicates that *Sreg* contains the selector for the symbol's defining segment.

## Discussion

ASSUME specifies the contents of the DS, SS, ES, FS, or GS register for the source code that follows until the next ASSUME statement for the register occurs. When an instruction references a variable, label, or external symbol, the assembler checks for the following:

- Either an explicit segment override specifies that the symbol is accessible via *Sreg*
- Or, an ASSUME specifies which *Sreg* holds the selector of the symbol's defining segment

See also: Segment overrides, Chapter 5

If neither has been specified, the assembler generates an error when an instruction references the symbol.

An ASSUME statement is in effect until it is changed by another ASSUME. For example, if you ASSUME some contents in DS, that assumption holds until you ASSUME new contents or NOTHING in DS.

When an `ASSUME` specifies an appropriate selector in DS, ES, FS, GS, or SS, the assembler generates any necessary segment override prefix byte when the symbol is referenced. Otherwise, a segment override must be specified every time the symbol is referenced.

`ASSUME CS:` may not be specified with the name of a segment or with a `SEG` expression.

## Specifying Segment Selectors with `ASSUME`

Specify an `ASSUME` wherever a new segment selector is loaded into a data or stack segment register.

When an `ASSUME` is specified as:

```
ASSUME Sreg:segspart [, ...]
```

*segs*part defines a selector as:

- A segment name, as in  
`ASSUME DS:DATA, ES:EDATA, FS:FDATA`
- Or, as a `SEG` expression with one of the following forms:

```
SEG varname  
SEG labelname  
SEG externalname
```

Assembler symbolic data (named variables, labels, or constants) represent logical addresses that consist of a segment selector plus an offset. The selector part locates the logical base address of the defining segment for the specified variable, label, or external symbol. Within the segment, the variable, label, or external symbol name represents an offset from this base address.

When `ASSUME Sreg:` segment name is in effect (see Example 1), the assembler generates relocatable addresses for symbolic and non-symbolic (anonymous) references via *Sreg*.

For `SEG` expressions, the *Sreg* is assumed to hold the selector of the segment in which the named variable, label, or external symbol is defined. Use a `SEG` expression to access variables, labels, and symbols when you do not know their defining segment's name (the segment is part of another module).

See also: `SEG` operator, Chapter 5

Both for segment names and for `SEG` expressions, the designated segment must have attributes that are consistent with the assumed segment register:

- For `SS`, the segment can be a stack segment, a data segment, or a data/stack combined segment. Its specified access must be `RW`.
- For `DS`, `ES`, `FS`, and `GS`, the segment may be a non-stack segment or a data/stack combined segment. Its access must be `RO`, `ER`, or `RW`.

Note that `CS` is illegal in an `ASSUME` statement that specifies a segment name or `SEG` expression; the assembler generates a warning.

## Examples

1. This example tells the assembler that the `ES` register holds the selector of the segment in which `ABYTE` is defined. The assembler generates an `ES` override byte and a relocatable address for the symbolic reference to `ABYTE` in `CSEG`. It also generates a relocatable address for the non-symbolic reference to `ES:BYTE PTR 0`.

```
    : :
ESEG SEGMENT RW USE32
    ABYTE DB ?
ESEG ENDS
    : :
CSEG SEGMENT ER USE 32
    : :
    ASSUME ES:ESEG
    MOV AL, ABYTE                ; assembler generates ES
                                ; override byte and
                                ; relocatable address
                                ; for ABYTE
    : :
    MOV AL, ES:BYTE PTR 0       ; ES:BYTE PTR 0 is also
                                ; relocatable
```

2. This example tells the assembler that the `DS` register holds the selector of the segment in which `ABYTE` is defined.

```
    : :
ASSUME DS:SEG ABYTE
```

3. The following example illustrates how the assembler handles ASSUME statements and checks memory accesses:

```

DATA SEGMENT RW PUBLIC
  ABYTE DB 0
  AWORD DW 0
DATA ENDS

EDATA SEGMENT RW PUBLIC
  WHERE DB 0
EDATA ENDS

:
CODE SEGMENT ER PUBLIC
  CBYTE DB 0 ; constant in CODE segment
ASSUME DS:DATA ; DATA segment
                ; is addressable through DS

:
MOV AX,DATA ; AX := selector for DATA
MOV DS,AX ; initialize DS
MOV AL,ABYTE ; ABYTE is in DATA segment
                ; and addressable via DS;
                ; instruction is OK
MOV BL,CBYTE ; CBYTE is in CODE segment,
                ; currently being assembled;
                ; instruction is OK and
                ; assembler will generate
                ; CS override byte
MOV CL,WHERE ; this is a program error:
                ; WHERE is in EDATA segment
                ; not covered by any ASSUME so
                ; assembler issues warning

MOV AX,EDATA
MOV ES,AX ; now ES can address
                ; WHERE but assembler
MOV CL,WHERE ; hasn't been told,
                ; so warning issued again

ASSUME ES:EDATA
MOV CL,WHERE ; is legal, because WHERE's
                ; segment, EDATA, is
                ; assumed to be in ES and
                ; assembler generates ES override

:
CODE ENDS

```

## Specifying ASSUME NOTHING and ASSUME CS:NOTHING

The general form:

```
ASSUME NOTHING
```

is equivalent to the following statement:

```
ASSUME CS: NOTHING, DS:NOTHING, ES:NOTHING,  
& FS:NOTHING, GS:NOTHING, SS:NOTHING
```

When an ASSUME is specified as:

```
ASSUME Sreg:NOTHING [, ...]
```

NOTHING indicates that no known value is in that segment register during the execution of the following code. If there is no segment register assumption in effect for a symbol's defining segment, references to that symbol must have an explicit DS, ES, FS, GS, or SS override (see Example 1). Note that this does not apply to symbols defined in code segments; the assembler always assumes that the code segment will be accessed via the CS register.

The assembler generates a non-relocatable address for a non-symbolic reference via *Sreg* when an ASSUME . . NOTHING is in effect for a particular segment register (see Examples 2 and 3).

When ASSUME CS:NOTHING is specified (see Example 3), the assembler generates a relocatable address relative to the current code segment for a symbolic reference in that segment. It generates a non-relocatable address for a non-symbolic reference.

When ASSUME CS:NOTHING is omitted (see Example 4), the assembler generates relocatable addresses both for symbolic and for non-symbolic references within the current code segment.

ASSUME . . NOTHING also affects the assembler's generation of pointer relocatable addresses within a data segment (see Example 5).

## Examples

1. This example shows how `ASSUME DS:DSEG` and `ASSUME DS:NOthing` affect symbolic references to `ABYTE` in `CSEG`.

```
ASSUME DS:DSEG
DSEG SEGMENT RW USE32
    ABYTE DB ?
DSEG ENDS
:
:
CSEG SEGMENT ER USE32
:
:           ; ASSUME DS:DSEG still in effect
MOV AL, ABYTE ; ABYTE is accessible,
:           ; assembler always generates
:           ; relocatable address
:           ; for valid symbolic reference

ASSUME DS:NOthing
MOV AL, ABYTE ; error generated
MOV AL, DS:ABYTE ; segment override so
:           ; no error
```

2. This example shows how `ASSUME DS:DSEG` and `ASSUME DS:NOthing` affect identical non-symbolic references in `CSEG`.

```
:
:           ; DSEG and CSEG defined as
:           ; in Example 1
ASSUME DS:DSEG ; assembler generates
MOV AL, DS:BYTE PTR 0
:           ; relocatable address
:           ; for DS:BYTE PTR 0
:
:
ASSUME DS:NOthing ; assembler generates
MOV AL, DS:BYTE PTR 0
:           ; non-relocatable address
:           ; for DS:BYTE PTR 0
```

3. This example shows how `ASSUME CS:NOTHING` affects symbolic and non-symbolic address generation. It causes the assembler to generate a relocatable address for `CVAL` but not for `CS:BYTE PTR 0`.

```

: :
CSEG SEGMENT ER PUBLIC
CVAL DB 90H
ENTRY:
ASSUME CS:NOTHING
MOV AL, CVAL                ; assembler generates
                            ; relocatable address for
                            ; symbolic reference

MOV AL, CS:BYTE PTR 0      ; non-relocatable address for
                            ; non-symbolic reference

: :

```

4. The same code (see Example 3) without `ASSUME CS:NOTHING` causes the assembler to generate relocatable addresses both for `CVAL` and for `CS:BYTE PTR 0`.

```

: :
CSEG SEGMENT ER PUBLIC
CVAL DB 90H
ENTRY:                        ; assembler generates
MOV AL, CVAL                  ; relocatable address for
                              ; symbolic reference

MOV AL, CS:BYTE PTR 0        ; relocatable address for
                              ; non-symbolic reference

: :

```

5. This example illustrates how `ASSUME ES:segname` and `ASSUME ES:NOTHING` affect the assembler's address generation within a data segment.

```

: :
ASSUME DS:DSEG, ES:ESEG
: : ; ESEG defined here
DSEG SEGMENT RW USE32
VAR1 DP ES:WORD PTR 0
; assembler generates
; pointer relocatable address
; for VAR1

: :
ASSUME ES:NOTHING
VAR2 DP ES:WORD PTR 0
; but not for VAR2

DSEG ENDS
```

□ □ □

# Program Linkage Directives 3

---

This chapter contains two major sections describing the five assembler directives that support modular programs:

- `NAME` and `END` directives

These directives delimit program modules. `NAME` specifies a unique name for each program module that the system utilities (binder and/or system builder) will combine and locate. `END` terminates each program module's assembly. `END` also specifies a program's main module: it defines the program's entry point (a label) and specifies the initial segment selector value for the CS (code) segment register; it may specify the initial segment selector values for the DS (data) and SS (stack) segment registers.

- `PUBLIC` directive

This directive defines variables and labels that can be accessed from another module. The `EXTRN` directive defines variables and labels that are accessed in one module and declared `PUBLIC` in another. The `COMM` directive defines variables as uninitialized symbols that will share storage with symbols of the same name in other modules.

The system utilities allocate storage for `COMM` variables. They also resolve `PUBLIC`, `EXTRN`, and `COMM` references.

## Modular Programming with `NAME` and `END`

An assembler program may omit the `NAME` statement only if the entire program is contained in a single object module. Otherwise, each module of the program should include a `NAME` statement.

Every assembler program must specify the `END` statement as the last line of source.

# NAME Directive

## Syntax

```
NAME modname
```

Where:

*modname* is a name for the module. *Modname* must be a unique identifier that occurs at most once within the program.

## Discussion

The `NAME` directive defines a name for an object module. Each module of an assembler program must have a unique name.

A `NAME` directive is usually placed at the beginning of a module. If the `NAME` directive does not appear anywhere in an object module, the assembler assigns the default name `ANONYMOUS` to the module and issues a warning. System utilities report an error if two or more program modules have the same name, including `ANONYMOUS`.

## Example

It is legal to specify the same name for a module as for the source file that contains it. The source file for this non-main module is called `SCAN.386`.

```
NAME SCAN          ; names the module
:
:
END
```

# END Directive

## Syntax

```
END [[CS:]labelname [,SS:segname] [,DS:segname]]
```

Where:

*labelname* is a name for the program entry point label; it must be a unique identifier. CS is initialized with the segment selector and EIP (or IP, for USE16 segments) is set to the offset of the specified label. *Labelname*'s defining segment must have an EO or ER access specification. *Labelname* may be specified only in the main module of a program.

*segname* is a segment name:

SS: A *segname* preceded by SS: causes the SS segment register to be initialized to the named segment's selector. The segment can be a stack segment defined with STACKSEG, or a data segment defined with the SEGMENT directive. The access specified for the segment must be RW. For a segment defined with STACKSEG, (E)SP is set to the offset of the first dword or word (depending on the stack segment use attribute) immediately above the stack segment limit in memory. (E)SP is 0 if the stack segment was not defined with STACKSEG. For a data segment, (E)SP is initialized to the segment's size in bytes plus 4 for a 32-bit stack or plus 2 for a 16-bit stack.

DS: A *segname* preceded by DS: causes the DS segment register to be initialized to the specified segment's selector. The segment can be a nonstack segment or a data/stack combined segment. Access specified for the segment must be RO, RW, or ER.

See also: SEGMENT . . ENDS directive, Chapter 2  
STACKSEG, Chapter 2

## Discussion

The `END` directive is required as the last statement in assembler modules. Its appearance terminates the assembly process. If the assembler encounters any text beyond the `END` directive, it issues a warning.

In the program's main module, the `END` statement must include a segment register initialization for `CS`. Non-main modules must specify `END` without segment register initializations.

The optional `DS:segname` and `SS:segname` specify the values to be loaded into the data and stack segment registers when the program is loaded. The assembler issues a warning if these are omitted in a module with an entry point label.

The module that contains the `END` statement initialization of `CS:EIP` specifies the code that is initially executed when the program is loaded into memory. Execution begins at the specified label. An entry point label must be specified in main modules, unless it is specified with the system builder. The `END` directive should also define the initial contents of `DS` and `SS`.

## Example

```
NAME MAIN

STACK STACKSEG 10

DATA SEGMENT RW
  ABYTE DB 0
DATA ENDS
  :
CODE SEGMENT ER
  ASSUME DS:DATA
START:MOV ESP, STACKSTART STACK
                                ; superfluous because SS
                                ; initialized with END

      MOV AL, ABYTE
  :
CODE ENDS
  :
END CS:START, DS:DATA, SS:STACK
```

# Defining Shared Data with PUBLIC, EXTRN, and COMM

Variables and labels defined in a program module with `PUBLIC` can be accessed from other modules where they are declared with `EXTRN`.

The `COMM` directive defines variables with undefined values whose storage is not allocated until the program modules are combined.

## PUBLIC Directive

### Syntax

```
PUBLIC name [, ...]
```

Where:

*name* is the identifier of a variable or label defined in the current module.

### Discussion

The `PUBLIC` directive specifies which symbols in a module are accessible from other modules after all modules are combined. These symbols can be variables, labels, or constants that have been defined using the `EQU` directive; it is an error to specify any other kind of symbol.

Named constants that are referenced in other modules must be declared `PUBLIC` in their defining module. An external constant must be an integer; it may be up to 32-bits long.



#### Note

Do not confuse this use of the reserved word `PUBLIC` with the `PUBLIC` segment attribute used in the `SEGMENT . . ENDS` statement.

See also: `SEGMENT . . ENDS` statement, Chapter 2

### Example

```
PUBLIC VAR 1, VAR 2
VAR 1 DBIT 0100B      ; VAR 1 and VAR 2 are made
VAR 2 DD 'ABCD'      ; accessible to other modules
                     ; when program is combined
```

# EXTRN Directive

## Syntax

```
EXTRN name: [type] [, ...] [use]  
EXTRN [use] name: [type] [, ...]
```

or

```
[use] EXTRN name: [type] [, ...]
```

Where:

- name* is the name of the external symbol, which must be declared `PUBLIC` or `COMM` in another module.
- type* is `BIT`, `BYTE`, `WORD`, `DWORD`, `PWORD`, `QWORD`, `TBYTE`, `ABS`, a defined record template name, a defined structure template name, `NEAR`, or `FAR`. Except for `ABS`, the type specification must match that of the external symbol, or the external symbol's type must be overridden with `PTR`.
- use* is `USE32` or `USE16`. The `USE` attribute specifies 32-bit or 16-bit addressing, respectively, for the named symbol or list of symbols. If no attribute is specified, the `USE` attribute of the nearest enclosing segment or module is assumed.

## Discussion

The `EXTRN` directive specifies symbols that are declared `PUBLIC` or `COMM` in another module. Such symbols can then be referenced in the current module.

All external variables have one of the following types: `BIT`, `BYTE`, `WORD`, `DWORD`, `PWORD`, `QWORD`, `TBYTE`, a structure template name, or a record template name. The type for a structure or record is its length in bytes. Structure and record template names cannot be forward references.

External constants can be signed integers up to 32-bits long (`USE32` segment) or up to 16-bits long (`USE16` segment). External constants must be declared `PUBLIC` in another module and be declared with `EXTRN:ABS` in modules that reference them. Such symbols are assigned type `DWORD` (`USE32 EXTRN`) or `WORD` (`USE16 EXTRN`).

All external labels and procedure labels have type `NEAR` or type `FAR`. The label or procedure is `NEAR` if it is defined in the same named segment as its callers; otherwise, it is `FAR`. If type is omitted, `FAR` is assumed for an `EXTRN` label.

See also: `PTR`, Chapter 5  
segment `USE` attributes, Chapter 2  
variable and label types, Chapter 4

## Placement of EXTRN

Within program segments, the following rules apply to the placement of the `EXTRN` directive:

1. If the external variable's or label's defining segment (in another module) is known, place the `EXTRN` statement between a `SEGMENT . .ENDS` pair that has the same segment name as the `SEGMENT . .ENDS` in which the symbol was defined.

Such a symbol can then be referenced in the same manner as any other variable or label. For example, if the module `SCAN.386` contained the following segment and variable definition:

```
DATA SEGMENT RW PUBLIC
    COUNT DB 0
    PUBLIC COUNT
DATA ENDS
```

then the `EXTRN` directive should be specified in another module as follows:

```
DATA SEGMENT RW PUBLIC
    EXTRN COUNT:BYTE
DATA ENDS
```

2. If the external symbol's defining segment is unknown, if its defining segment is non-combinable, or if the symbol is an `EXTRN:ABS` constant, place the `EXTRN` statement outside of all `SEGMENT . .ENDS` pairs in the module. To address such an external symbol, load the segment selector of the symbol into a segment register using the `SEG` operator. For example:

```
MOV AX, SEG COUNT
MOV ES, AX
```

To validate its addressability, use an `ASSUME` directive such as the following:

```
ASSUME ES:SEG COUNT
MOV DX, COUNT
```

or use a segment override for each reference to the symbol as in the following:

```
MOV DX, ES:COUNT
```

See also: `SEG` and segment overrides, Chapter 5  
`ASSUME` directive, Chapter 2

# COMM Directive

## Syntax

```
COMM name[, ...]
```

Where:

*name* is a variable name; it must be a unique identifier. *Name* may not be a variable of type `BIT`.

## Discussion

The `COMM` directive specifies that a variable defined in the current module is a `COMM` symbol. `COMM` symbols are classified as global variables.

The `COMM` directive allows the binder to allocate space for a symbol at bind time. Variables specified with `COMM` in more than one module share storage space. They are similar to `FORTRAN` blank common variables or C extern variables.

Variables declared with `COMM` cannot be initialized. Use a `?` when defining `COMM` variables to indicate uninitialized storage.

See also: Allocating uninitialized storage, Chapter 4

The `COMM` directive may appear inside or outside the segment in which the variable is defined. `COMM` may be placed before the definition of the variable it describes (see the Example).

Variables cannot be declared `EXTRN` in the same module where they are declared with `COMM`. They may be declared with `PUBLIC` or with `EXTRN` in other modules, as well as with `COMM`.

A `COMM` symbol does not actually occupy space in a segment until bind time. The binder determines whether a variable reference will be resolved by a matching `PUBLIC` definition from another module or whether space will be allocated for it in a segment where the `COMM` symbol is defined. If a variable is not declared `PUBLIC` in another module, the binder will allocate space for `COMM` data in the first-bound module (and segment) in which it encounters the `COMM` symbol.

A `COMM` symbol may have a different type than its `PUBLIC` counterpart (with the same name) in another module. However, such a `COMM` symbol is treated as an `EXTRN` symbol; the binder stores the `COMM` symbol in the corresponding `PUBLIC` symbol's defining segment.

A `COMM` symbol that has no `PUBLIC` counterpart in another module is treated as a `PUBLIC` symbol. The binder allocates storage for the `COMM` symbol in the first-bound segment where it is defined. The binder then resolves subsequent references (`COMM` or `EXTRN`) to that symbol.

A `COMM` symbol's containing storage segment is determined by the binder. For this reason, loading a segment register in assembler modules with the name of a `COMM` symbol's defining segment is difficult. Use the `SEG` operator to reference `COMM` symbols in modules. For subsequent symbolic references, use the `SEG` operator again to reload the correct segment selector into the segment register.

## Example

```
NAME MOD 1
COMM X, Z           ; COMM statement before data definition
                   ; outside of defining segment
DATA SEGMENT RW PUBLIC
COMM A, B           ; COMM statement before data definition
A DW 13 DUP (?)    ; inside defining segment
B DB ?
X DW ?
Z DD ?

LOCAL DD ?
DATA ENDS
END
```





# Defining And Initializing Data 4

---

This chapter has four major sections:

- An overview of assembler labels, variables, and data

This section explains:

- Assembler label and variable types
- The relationship between assembler variable types and the values associated with variables: the processor or floating-point coprocessor data types
- How to specify data values in assembler programs

- Assembler variables

This section explains:

- Storage allocations for variables
- Variable attributes
- Defining and initializing simple-type variables with the `DBIT`, `DB`, `DW`, `DD`, `DP`, `DQ`, and `DT` directives
- Defining compound types with the `RECORD` and `STRUC` directives; defining and initializing variables of these types (records and structures)
- Defining and initializing variables with `DUP` clause(s)

- Assembler labels

This section explains:

- Label attributes
- The location counter and the `ORG` and `EVEN` directives
- The `LABEL` directive
- Defining implicit `NEAR` labels
- The `PROC` directive

- Using symbolic data, including named variables and labels, with the `EQU` and `PURGE` directives

# Overview of Assembler Labels and Variables

The labels and variables in an assembler program define logical addresses:

- A label defines an address that is either an offset within the segment currently being assembled or a location outside the current segment whose address is both a segment selector and an offset within that segment.
- A named variable also defines an address whose contents (a value) can be accessed by a reference to the variable name.

Labels and named variables are sometimes called symbolic addresses because their names represent logical addresses. However, assembler variables are not required to have names, as long as their values can be accessed.

See also: Accessing assembler addresses and values, Chapter 5

## Assembler Label and Variable Types

The assembly language is strongly typed. The assembler enforces type rules when it encounters a label or allocates storage for a variable (named or unnamed).

Each assembler label has one of the following types:

- NEAR indicates that the logical address represented by the label is an offset. NEAR is the default label type.
- FAR indicates that the logical address represented by the label is both a selector and an offset.

Each assembler variable has a type that must be specified when the variable is defined with a storage allocation statement. A variable's type indicates the processor or floating-point coprocessor storage size for the variable's value(s). A variable's type is either a simple type or a compound type. A compound type is constructed from one or more simple types.

The assembler (reserved word) names for simple types are BIT, BYTE, WORD, DWORD, PWORD, QWORD, and TBYTE. For BIT-type variables, the assembler allocates a byte of storage because processor addresses fall on byte boundaries. For variables of the other simple types, the assembler allocates storage of 8-, 16-, 32-, 48-, 64-, or 80-bits, respectively.

A compound-type variable is either a record or a structure. Records and structures are programmer-defined (and named) types. A record or structure template defines a type that specifies the storage size(s) to be allocated for any variable of the type. Record and structure storage allocation statements define assembler variables of these types.

A `DUP` clause can be added to any assembler storage allocation statement to allocate a sequence of storage units that are all of the same type. `DUP` allocates storage for array-like variables whose elements are contiguous storage units, possibly with different values.

## Assembler Data Values

The processor or floating-point coprocessor stores all data as a sequence of 1s and 0s. The value that such a sequence represents is subject to interpretation. The assembler interprets values in the context of a program. For example, the logical address represented by a label is 32-bits in a `USE32` code segment; it is 16-bits in a `USE16` segment.

The value of an assembler variable also has meaning only in context. If a variable is used as the operand of a shift instruction, its corresponding value represents a simple sequence of bits. If the same variable is used as the operand of a subtract instruction, its corresponding value represents a number.

The contextually determined meaning of a variable value is called its processor or floating-point coprocessor data type.

## Data Types

The values of assembler variables can be interpreted as the following processor and floating-point coprocessor data types:

- Processor or floating-point coprocessor signed integers
- Processor ordinals
- Processor unpacked or packed BCD digit(s)
- Floating-point coprocessor packed BCD integers
- Processor strings
- Processor bit strings or bit fields
- Processor near or far pointers
- Floating-point coprocessor reals

For example, the value of a `DWORD`-type variable can represent any of the following in the context of a program:

- A processor integer or a floating-point coprocessor short integer
- A processor ordinal
- A processor string that is 4 bytes long
- A processor bit string that is 32-bits long (it may contain a bit field up to 32-bits long)
- A floating-point coprocessor single precision real

To access strings, `BYTE`-type assembler variables must be defined. Processor strings are composed of contiguous bytes. The name of a `BYTE`-type variable (or the unnamed but initially allocated storage unit) defines the logical address of such a string's first byte.

Assembler pointer variables are 32-bit `DWORD` or 48-bit `PWORD` types that represent a logical address. `DWORD` (near) pointer variables represent an offset within a segment. `PWORD` (far) pointers have two components: a 16-bit segment selector and a 32-bit offset.

The assembler types `WORD`, `DWORD`, `QWORD`, and `TBYTE` can represent 16-, 32-, 64-, and 80-bit floating-point coprocessor data types. 16-bit data is a word integer, 32-bit data is either a short integer or a single precision real, 64-bit data is either a long integer or a double precision real, and 80-bit data is either a packed decimal integer or an extended precision real.

See also: Floating-point numbers, Chapter 7

## Numeric Data Value Ranges

The type specified for a variable determines the range of values it can represent. The assembler checks variable definitions for initial values that are too large for the declared type. Table 4-1 summarizes the (decimal) range of values for each variable type that can represent a processor or floating-point coprocessor number.

**Table 4-1. Assembler Variable Types and Numerical Value Ranges**

| Variable Type | Data Type        | Length in bits | Value Range in Decimal                                                 |
|---------------|------------------|----------------|------------------------------------------------------------------------|
| BIT           | bit              | 1              | 0 or 1 binary                                                          |
| BYTE          | byte             | 8              | -28..127 for integers<br>0..255 for ordinals                           |
| WORD          | word             | 16             | -32,768..32,767 for integers<br>0..65,535 for ordinals                 |
| DWORD         | FP word integer  | 32             | 32,768..32,767                                                         |
|               | dword            |                | $-2^{31}..(2^{31} - 1)$ for integers<br>$0..(2^{32} - 1)$ for ordinals |
|               | FP short integer |                | $-2^{31}..(2^{31} - 1)$                                                |
| QWORD         | FP single        | 64             | -3.4E38..-1.2E-38, 0.0,<br>precision real                              |
|               | FP long integer  |                | $-2^{63}..(2^{63} - 1)$                                                |
|               | FP double        |                | -1.7E308..-2.3E-308, 0.0,<br>precision real                            |
| TBYTE         | FP packed        | 80             | $-(10^{18} - 1)..(10^{18} - 1)$                                        |
|               | decimal integer  |                |                                                                        |
|               | FP extended      |                | -1.1E4932..-3.4E-4932,<br>precision real                               |
|               |                  |                | 0.0, 3.4E-4932..1.1E4932                                               |

FP in Table 4-1 indicates a floating-point coprocessor data type.

## Specifying Assembler Data Values

Assembler data can be expressed in binary, hexadecimal, octal, decimal, or ASCII form. Decimal values that represent integers or reals can be specified with a minus sign; a plus sign is redundant but accepted. Real numbers can also be expressed in floating-point decimal or in hexadecimal notations. Table 4-2 summarizes the valid ways of specifying data values in assembler programs.

**Table 4-2. Assembler Data Value Specification Rules**

| Value in    | Examples |               | Rules of Formation                                                                                                                                                                                                                                                                     |
|-------------|----------|---------------|----------------------------------------------------------------------------------------------------------------------------------------------------------------------------------------------------------------------------------------------------------------------------------------|
| Binary      | 1100011B | 110B          | A sequence of 0's and 1's followed by the letter B.                                                                                                                                                                                                                                    |
| Octal       | 7777O    | 4567Q         | A sequence of digits in the range 0..7 followed by the letter O or the letter Q.                                                                                                                                                                                                       |
| Decimal     | 3309     | 3309D         | A sequence of digits in the range 0..9 followed by an optional letter D.                                                                                                                                                                                                               |
| Hexadecimal | 55H      | 4BEACH        | A sequence of digits in the range 0..9 and/or letters A..F followed by the letter H. A digit must begin the sequence.                                                                                                                                                                  |
| ASCII       | 'AB'     | 'UPDATE.EXT'  | Any ASCII string enclosed in single quotes.                                                                                                                                                                                                                                            |
| Decimal     | -1.      | 1E-32 3.14159 | A rational number that may be preceded by a sign and followed by an optional exponent. A decimal point is required if no exponent is present but is optional otherwise. The exponent begins with the letter E followed by an optional sign and a sequence of digits in the range 0..9. |
| Hexadecimal | 40490FR  | 0C0000R       | A sequence of digits in the range 0..9 and/or letters A..F followed by the letter R. The sequence must begin with a digit, and the total number of digits and letters must be (8/16/20) or (9/17/21 with the first digit 0).                                                           |

A real hexadecimal specification must be the exact sequence of hex digits to fill the internal floating-point coprocessor representation of the floating-point number. For this reason, such values must have exactly 8, 16, or 20 hexadecimal digits, corresponding to the single, double, and extended precision reals that the floating-point coprocessor and the floating-point instructions handle. Such values can have 9, 17, or 21 hexadecimal digits only if the initial digit must be a zero because the value begins with a letter.

Data values can be specified in an assembler program in a variety of formats, as shown in Table 4-2. The way the processor or floating-point coprocessor represents such data internally is called its storage format.

See also: Processor storage formats, Appendix A  
floating-point coprocessor storage formats, Chapter 7

## Initializing Variables

Assembler variables can be initialized by:

- Variable or segment names that represent logical addresses
- Constants (see Table 4-2)
- Constant expressions

A series of operands and operators is called an expression. An expression that yields a constant value is called a constant expression.

See also: Assembler expressions, Chapter 5

The assembler evaluates constant expressions in programs.

## How the Assembler Evaluates Constant Expressions

The assembler can perform arithmetic operations on 8-, 16-, and 32-bit numbers. The assembler interprets these numbers as integer or ordinal data types.

An integer value specified with a sign is a constant expression. The assembler evaluates integer or ordinal operands and expressions using 64-bit two's complement integer arithmetic.

By using this arithmetic, the assembler can evaluate expressions whose operands' sizes might extend beyond the storage type of the result. As long as the expression's value fits in the storage type of the destination, the assembler does not generate an error when intermediate results are too large. The assembler does generate an error if the final result is too large to fit in the destination.

# Variables

A variable defines a logical address for the storage of value(s). An assembler variable is not required to have a name as long as its associated value(s) are accessible. But, every variable has a type; records and structures have a compound type.

Assembler variables must be defined with a storage allocation statement. A storage allocation specifies a type (storage size in bytes) and defines a logical address for a variable that gives access to the variable's value(s). A storage allocation statement may also specify initial value(s) for a variable.

Use the `DBIT`, `DB`, `DW`, `DD`, `DP`, `DQ`, or `DT` directive to allocate storage for simple-type variables of the following sizes:

|                   |                                        |
|-------------------|----------------------------------------|
| <code>DBIT</code> | 1-bit (zero padded to a byte boundary) |
| <code>DB</code>   | 8-bits (byte)                          |
| <code>DW</code>   | 16-bits (word)                         |
| <code>DD</code>   | 32-bits (dword)                        |
| <code>DP</code>   | 48-bits (pword)                        |
| <code>DQ</code>   | 64-bits (qword)                        |
| <code>DT</code>   | 80-bits (10 bytes)                     |

Use the `RECORD` and `STRUC` directives to define type names that can be specified as (compound) types for record or structure variables:

## The `RECORD` Directive

defines a storage template for variables of its type. The template defines 1 to 4 bytes of storage for fields of bits. Use a record allocation statement to define a variable of the record type. Variables of a record type consist of contiguous fields of bit-encoded data. Records are used for accessing specific bits in the flags, in the storage fields of a real number, in the fields of a pointer, etc. The assembler `MASK`, `SIZE`, and `WIDTH` operators can be used to access record fields.

See also: `MASK`, `SIZE`, and `WIDTH` operators, Chapter 5

### The STRUC Directive

defines a storage template with named fields, each of a specified type. Variables of a structure type consist of contiguous variables with the types (and names) of the constituent template fields. Structure template fields are simple variables, usually initialized with undefined values. Use a structure allocation statement to define a variable of this type.

A structure template's field names define offsets from a logical address. Any memory location pointed to by a base or index register becomes an undeclared variable of the structure type if it is used to reference a field name with the dot operator (e.g., `[EBP].fieldname`).

Use a DUP clause within any assembler data allocation statement to allocate and optionally initialize a sequence of storage units of a single variable type. DUP defines an array-like variable whose element values are accessed by an offset from the variable name or from the initially specified storage unit.

## Simple Data Allocations

Both simple-type variables and the components of compound types are defined by simple data allocation statements. The general syntax of a simple data allocation statement is:

### Syntax

```
[name] dtyp init [, ...]
```

Where:

- name* is the name of the variable. Within the module, it must be a unique identifier.
- dtyp* is DBIT, DB, DW, DD, DP, DQ, or DT.
- init* is the initial value to be stored in the allocated space. *init* can be a numeric constant (expressed in binary, hexadecimal, decimal, or octal), an ASCII string, or (except for BIT-type variables) the question mark character (?), which specifies storage with undefined value(s). *dtyp* restricts the values that may be specified for *init*.

Record and structure allocation statements define compound-type variables.

## Variable Attributes

A defined variable has four attributes:

- |         |                                                                                                                                                                                                                                                                                                                                                                                                                                                                                         |
|---------|-----------------------------------------------------------------------------------------------------------------------------------------------------------------------------------------------------------------------------------------------------------------------------------------------------------------------------------------------------------------------------------------------------------------------------------------------------------------------------------------|
| Segment | The segment in which the variable is defined. The value of a variable's segment attribute is the selector for its segment.                                                                                                                                                                                                                                                                                                                                                              |
| USE     | The <code>USE32</code> or <code>USE16</code> of the segment in which the variable is defined.<br><br>See also: Segment <code>USE</code> attributes, Chapter 2                                                                                                                                                                                                                                                                                                                           |
| Offset  | The variable's logical address within its defining segment. This value represents the distance in bytes from the base (or start) of the defining segment to the start of the variable in memory. For <code>USE32</code> segments, the offset is a 32-bit value; for <code>USE16</code> segments, it is a 16-bit value.                                                                                                                                                                  |
| Type    | The size in bytes of the variable. For simple-type variables, the data initialization directive ( <code>DBIT</code> , <code>DB</code> , <code>DW</code> , <code>DD</code> , <code>DP</code> , <code>DQ</code> , or <code>DT</code> ) specifies the type. For compound variables, the type is a programmer-defined record or structure template name. A variable's type determines how it can be used in an instruction and, in some cases, how data will be stored within the variable. |

When a variable is defined in a program, the assembler will store its definition, which includes its attributes.

See also: Chapter 5 for more information about expression operators that override these attributes and access their values

## Defining and Initializing Variables of a Simple Type

All assembler variable definitions use the DBIT, DB, DW, DD, DQ, DP, or DT directives. The template components of compound variable types are simple types defined with these directives.

### DBIT Directive

#### Syntax

```
[name] DBIT init [,...]
```

Where:

*name* is the name of the variable. Within the module, it must be a unique identifier.

*init* is a binary digit (1 or 0) followed by the letter B or b, or a string of up to 32 binary digits followed by the letter B or b.

#### Discussion

DBIT reserves storage for and initializes a single-bit variable or a bit string of type BIT. If *init* is not specified explicitly, the assembler assigns a 0 and issues a warning.

DBIT actually reserves an entire byte of storage for a 1-bit variable (unless it is defined within a structure) because processor addresses fall on byte boundaries. DBIT fills one or more bytes for an *init* list with the specified values and zero-pads such a variable out to the nearest byte boundary. DBIT variables defined one at a time occupy consecutive bytes in memory.

Within an assembler structure consecutively defined bit variables will be concatenated; they are stored as contiguous bits in memory and they can cross byte boundaries.

## Examples

1. The DBIT directive initializes a full byte for simple BIT variables, even when fewer than 8 digits are specified for an initial value.

```
ONEBIT DBIT 1B          ; initializes a byte to 00000001
TWOBITS DBIT 10B       ; initializes a byte to 00000010
```

2. For each BIT-type variable defined outside a structure, the DBIT directive concatenates an init list and pads the value with zeros out to the nearest byte boundary. However, each variable defined with DBIT is allocated storage separately.

```
BIT1 DBIT 1B, 0B, 1B, 0B, 1B ; 00010101 is initial value
BIT2 DBIT 1B                  ; 00000001 is initial value
BIT3 DBIT 10B                 ; 00000010 is initial value
```

3. For BIT-type fields of a structure, the assembler concatenates contiguous bit fields and pads the value out to the nearest byte boundary. Structure fields of type BIT can cross byte boundaries.

```
BITSTRUK STRUC
BIT1 DBIT 1B, 0B, 1B, 0B, 1B
BIT2 DBIT 1B
BITSTRUK ENDS

BITS BITSTRUK <> ; 00110101 is initial value stored
```

## DB Directive

### Syntax

```
[name] DB init [,...]
```

Where:

*name* is the name of the variable. Within the module, it must be a unique identifier.

*init* is a question mark (?), a constant expression, or a string of up to 255 ASCII characters enclosed in single quotes ('').

### Discussion

DB reserves storage for and optionally initializes a variable of type `BYTE`. ? reserves storage with an undefined value.

Numeric initial values can be specified in binary, octal, decimal, or hexadecimal (see Table 4-2). The specified constant or constant expression must evaluate to a number in the range 0..255 (processor ordinal) or -128..127 (processor integer).

The components of character string values must be ASCII characters and the whole string must be enclosed in single quotes. To include a single quote character within such a string, specify two single quotes ('').

Each ASCII character requires a byte of storage. In `BYTE` strings, successive characters occupy successive bytes. The name of the variable represents the logical address of the first character in such a string.

### Examples

1. This example initializes the variable `ABYTE` to the constant value 100 (decimal). It reserves storage for another byte with an undefined value.

```
ABYTE DB 100  
DB ?
```

2. This example initializes three successive bytes to the values 4, 10, and 200, respectively.

```
BYTES3 DB 4,10,200
```

3. This example initializes seven bytes containing the ASCII values of the characters A, B, C, ', D, E, and F, respectively.

```
STRGWQUOT DB 'ABC''DEF'
```

## DW Directive

### Syntax

```
[name] DW init [,...]
```

Where:

*name* is the name of the variable. Within the module, it must be a unique identifier.

*init* is a question mark (?), a constant expression, the name of a variable or label defined in a USE16 segment, the name of a segment (USE16 or USE32), or a string of up to 2 characters enclosed in single quotes (').

### Discussion

DW defines storage for and optionally initializes a 16-bit variable of type WORD. ? reserves storage with an undefined value.

Numeric initial values can be specified in binary, octal, decimal, or hexadecimal (see Table 4-2). The specified constant or constant expression must evaluate to a number in the range 0..65535 (processor ordinal) or -32768..32767 (processor integer).

A USE16 variable or label name yields an initial value that is the offset of the variable or label. It is an error to initialize a WORD variable with the name of a variable or label that has been defined in a USE32 segment; its offset is too large (32-bits). A segment name yields an initial value that is the segment selector.

A 1- or 2-character string yields an initial value that is interpreted and stored as a number. The assembler stores a 2-byte value even if the specified string has only one character:

- It stores the specified initial value in the least significant byte.
- It zeros the remaining byte.

## Examples

1. This example tells the assembler to reserve storage for two uninitialized words.

```
UNINIT DW ?,?
```

2. This example initializes WORD variables with numeric values.

```
CONST DW 5000           ; decimal constant  
HEXEXP DW OFFFH -10    ; expression
```

3. This example initializes VAR1OFF to the offset of VAR1 (both variables are within a USE16 segment) and CODESEL to the selector of a segment named CODE.

```
VAR1OFF DW VAR1  
CODESEL DW CODE
```

4. This example initializes NUMB to the ASCII value (interpreted as a number) of the letters AB.

```
NUMB DW 'AB'           ; equivalent to NUMB DW 4142H
```

## DD Directive

### Syntax

```
[name] DD init [,...]
```

Where:

*name* is the name of the variable. Within the module, it must be a unique identifier.

*init* is a question mark (?), a constant expression, the name of a variable or label, or a string of up to 4 characters enclosed in single quotes (').

### Discussion

DD defines storage for and optionally initializes a 32-bit variable of type `DWORD`. ? reserves storage with an undefined value.

Integer initial values can be specified in binary, octal, decimal, or hexadecimal (see Table 4-2). The specified constant or constant expression must evaluate to a number in the range:

$-2^{31} \dots 2^{31}-1$  (processor integer or floating-point coprocessor short integer)

Or,  $0 \dots 2^{32}-1$  (processor ordinal)

Real initial values can be specified in floating-point decimal or in hexadecimal (see Table 4-2). A decimal constant must evaluate to a real in the ranges:

$-3.4E38 \dots -1.2E-38, 0.0, 1.2E-38 \dots 3.4E38$   
(floating-point coprocessor single precision real)

A constant expressed as a hexadecimal real must be the exact sequence of hex digits to fill the internal floating-point coprocessor representation of a single precision real (8 hexadecimal digits or 9 hexadecimal digits, including an initial 0).

A `USE16` variable or label name yields an initial value that fills the dword. Its high-order word contains the segment selector and its low-order word contains the offset of the `USE16` variable or label.

A `USE32` variable or label name yields an initial value that is the offset (from the segment base) of the variable or label.

A string (up to four characters) yields an initial value that is interpreted and stored as a number. The assembler stores a 4-byte value even if the specified string has fewer than four characters:

- It stores the specified initial values in the least significant bytes.
- It zeros the remaining bytes.

## Examples

1. This example defines two variables, a floating-point coprocessor short integer and a single precision real.

```
INTVAR DD 1234567
REALVAR DD 1.6E25
```

2. In this example, LAB1 was defined in a USE16 segment and LAB2 was defined in a USE32 segment.

```
LAB1_ADD DD LAB1      ; LAB1_ADD contains offset and
                    ; segment selector of LAB1

LAB2_ADD DD LAB2      ; LAB2_ADD contains offset of LAB2
```

3. This example initializes three unnamed dwords. The first contains an undefined value. The second contains the ASCII numeric value of the letter A. The third contains the integer 450 (decimal).

```
DD ?, 'A', 450
```

## DP Directive

### Syntax

```
[name] DP init [,...]
```

Where:

*name* is the name of the variable. Within the module, it must be a unique identifier.

*init* is a question mark (?), an integer constant expression, the name of a variable or label, the name of a segment, or a string of up to 6 characters enclosed in single quotes (').

### Discussion

DP defines storage for and optionally initializes a 48-bit variable of type `PWORD`. ? reserves storage with an undefined value.

Numeric initial values can be specified in binary, octal, decimal, or hexadecimal. The specified constant expression must evaluate to an integer in the range:

$$-2^{47} \dots 2^{47}-1.$$

Constants used to initialize pwords cannot be expressed as real numbers.

A variable or label name (whatever the `USE` attribute of its defining segment) yields an initial value that fills the pword. The pword will contain both the variable's or label's offset and the segment selector (16-bits). The low-order dword stores the offset.

A segment name yields an initial value that is a logical address consisting of the segment selector (16-bits) and an offset of zero (32-bits) to the start of the named segment.

A string (up to six characters) yields an initial value that is interpreted and stored as a number. The assembler stores a 6-byte value even if the specified string has fewer than six characters:

- It stores the specified initial values in the least significant bytes.
- It zeros the remaining bytes.

## Examples

1. This example initializes the low-order byte to the ASCII value (interpreted as a number) of the digit 1, and the five high-order bytes to zero.

```
DP '1'          ; first byte contains 31H
                ; remaining bytes contain 00000000
```

2. This example initializes `VARPTR` to the segment selector and offset of `VAR32`.

```
VARPTR DP VAR32
```

## DQ Directive

### Syntax

```
[name] DQ init [,...]
```

Where:

*name* is the name of the variable. Within the module, it must be a unique identifier.

*init* is a question mark (?), a constant expression, or a string of up to eight characters enclosed in single quotes (').

### Discussion

DQ defines storage for and optionally initializes a 64-bit variable of type `QWORD`. The ? reserves storage with an undefined value.

Integer initial values can be specified in binary, octal, decimal, or hexadecimal (see Table 4-2). The specified constant expression must evaluate to an integer in the range  $-2^{63} \dots 2^{63}-1$  (floating-point coprocessor long integer).

Real initial values can be specified in floating-point decimal or hexadecimal (see Table 4-2). A decimal constant or expression must evaluate to a real in the ranges:

```
-1.7E308..-2.3E-308, 0.0,  
2.3E-308..1.7E308
```

(floating-point coprocessor double precision real).

A real hexadecimal constant must be the exact sequence of hex digits to fill the internal floating-point coprocessor representation of a double precision real (16 hexadecimal digits or 17 hexadecimal digits, including an initial 0).

A string (up to 8 characters) yields an initial value that is interpreted and stored as a number. The assembler stores an 8-byte value even if the specified string has fewer than 8 characters:

- It stores the specified initial values in the least significant bytes.
- It zeros the remaining bytes.

## Examples

1. This example initializes `VAR6` to a floating-point coprocessor double precision real and `VAR7` to the same value in real hexadecimal notation.

```
VAR6 DQ -3.6E-200           ; decimal notation
VAR7 DQ 96860B837993DEE8R   ; real hexadecimal notation
```

2. This example allocates 64-bits of storage for `UNDEFNUM` with an undefined value.

```
UNDEFNUM DQ ?
```

3. This example initializes `CHAR`'s low-order byte to the ASCII value (interpreted as a number) of the comma, and its seven high-order bytes to zero.

```
CHAR DQ ','                ; first byte contains 2CH
                          ; remaining bytes contain 00000000
```

## DT Directive

### Syntax

```
[name] DT init [,...]
```

Where:

*name* is the name of the variable. Within the module, it must be a unique identifier.

*init* is a question mark (?) or a constant expression.

### Discussion

DT defines storage for and optionally initializes an 80-bit variable of type `TBYTE`.  
? reserves storage with an undefined value.

A constant expression must evaluate to an integer or real in the range(s):

$-10^{18}-1 \dots 10^{18}-1$  (floating-point coprocessor packed decimal integer)

Or,

$-1.1E4932 \dots -3.4E-4932, 0.0, 3.4E-4932 \dots 1.1E4932$   
(floating-point coprocessor extended precision real).

Real initial values can be specified in floating-point decimal or in hexadecimal (see Table 4-2).

A hexadecimal real constant must be the exact sequence of hex digits to fill the internal floating-point coprocessor representation of an extended precision real (20 hexadecimal digits or 21 hexadecimal digits, including an initial 0).

### Examples

1. This example allocates 80-bits of storage for `ATBYTE` with an undefined value.

```
ATBYTE DT ?
```

2. This example initializes `EVAR1` to a floating-point coprocessor extended precision real and `EVAR2` to the same value in real hexadecimal notation.

```
EVAR1 DT 9E-15  
EVAR2 DT 3FD0A2212C962206C274R
```

## Defining Compound Types and Their Variables

The `RECORD` and `STRUC` directives define the names of compound types, together with a storage allocation template.

The `RECORD` directive defines a template that specifies the size and fields for variables of the record type. Use the record template name in a record allocation statement to allocate storage for and initialize variables of a record type.

An assembler record consists of contiguous fields of bit-coded data. Records can be defined to format bytes, words, or dwords for bit-packing. A record template can be from 1 to 4 bytes in size. Each record of the template type has a specific number of fields, and each field contains a specific number of bits. Information can be stored in and accessed from these fields.

The `STRUC` directive defines a template with named and typed fields, optionally with default data values. Each field is of a simple type (defined with `DBIT`, `DB`, `DW`, `DD`, `DP`, `DQ`, or `DT`), but every field in a template may be of a different type.

Use structure templates to group associated data, such as the storage format fields of floating-point coprocessor real numbers or the fields of a pointer. Use structure templates to impose structure on memory data that will be accessed by a base or index register.

Use the structure template name as the type in a structure allocation statement to allocate storage for and initialize variables of the structure type. ASM386 structures are allocated memory in the same way bytes, words, and dwords are allocated. Their fields can be accessed readily using the notation:

*Structure-name.field-name*

The (optional) default values of structure template fields can be:

- Overridden when a structure variable is allocated and initialized
- Accessed or overwritten during program execution

See also:    Accessing structure template fields, Chapter 5  
              overwriting structure template fields, Chapters 6 and 7

# RECORD Directive

## Syntax

```
name RECORD field: exp [=init-val] [,...]
```

Where:

- name* is an identifier that creates a record template type name; *name* must be unique within the module.
- field* is an identifier that defines a bit field within the record type; *field* must be unique within the module.
- exp* is a constant expression that evaluates to the number of bits in the *field*. *exp* must evaluate to an ordinal in the range 1..32. The maximum number of bits in a record is 32, so it is an error if the sum of a record template's *exps* is greater than 32.
- init-val* is a constant expression or a character string enclosed in single quotes (').

## Discussion

RECORD creates a BYTE-, WORD-, 3-BYTE- or DWORD-sized record template definition. Record variables can then be allocated and initialized through the use of the record name in a record allocation statement (see the next section).

Numeric initial values can be specified in binary, octal, decimal, or hexadecimal (see Table 4-2). The specified constant expression must evaluate to a non-negative integer value that fits in its field.

A character string has a maximum length of four characters because the maximum size of a record is 4 bytes and each ASCII character requires a byte of storage.

The first field specified in the record template occupies the most significant bits when data is allocated for a record of the (template) type. Record template fields (and their default values) are not required to fill to a byte boundary. A record template whose fields do not occupy a full BYTE, WORD, or DWORD is called a partial record.

The assembler right-justifies fields within a partial record and pads the record (with zeros) out to the next byte boundary. A record whose fields total 17..23 bits is padded to 24-bits (3 bytes). Figure 4-1 illustrates an example of a partial record.

Record Template:  
 Partial Record A:16, B:9

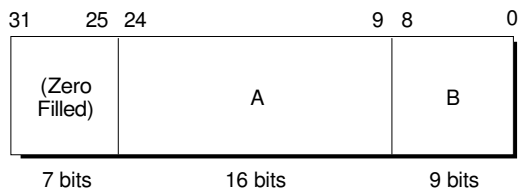

W-3420

**Figure 4-1. Partial Record Definition Template**

## Examples

1. This example defines a `DWORD`-sized record template, even though it specifies 30-bits total for its fields (processor addresses must fall on byte boundaries).

```
ERRFLAGS RECORD IO:3=0, SYS:3=0, MEM:24=`ABC`
```

2. This example defines a record template for floating-point coprocessor single precision reals (the template matches the floating-point coprocessor storage format).

```
SIGNEDNUM RECORD SIGN:1, EXP:8, FRAC:23
```

# Record Allocation Statement

## Syntax

```
[name] recnm < [exp] [, ... ] >
```

Where:

- name* is an identifier; *name* must be unique within the module.
- recnm* is the name of the record template that defines how bit-fields are to be allocated for the variable of the type. *recnm* may be followed by a DUP clause.
- exp* is a value that overrides the default field value allocated for the record. *exp* must evaluate to a number that will fit in the field specified in the record template definition) that is to be overridden; it may be a ? (undefined value).

## Discussion

This statement allocates data in the form specified by the previously defined record template. Default field values specified by the RECORD directive can be overridden. The following rules must be observed for *exp*:

- To allocate a record without overriding the default values, specify <> (no *exp* values).
- Assuming a record with fields <*f1*, *f2*, *f3*, . . . , *fn*>, specify a comma for each field with an acceptable default value and specify an overriding *exp* for each *fn* to be overridden.

For example, use the following to override (*f3* and *f4*) or *fn*, respectively:

```
< , , 2, 5 >  
< , , . . . , 2 >
```

After the last field to be overridden, commas need not be specified for remaining fields. In the first preceding example, commas must be specified only for *f1* and *f2* (the *f5* . . . *fn* default values are acceptable).

- Use a ? to override a default field value (zero used).
- A field defined with a single string of two or more characters can be overridden only with another string. The overriding string need not be the same length as the record template's. If the overriding string is shorter than the original string, the remaining characters of the default string are used. If the overriding string is longer but still fits in the field, the overriding string is used. Otherwise, the assembler generates an error.

## Examples

1. This example allocates two record variables of type `ERRFLAGS` (this record template is defined in Example 1 of the preceding section). `FLAGS1` uses the `ERRFLAGS` default values without overrides. `FLAGS` overrides the defaults defined with `ERRFLAGS`.

```
FLAGS1 ERRFLAGS<>
FLAGS ERRFLAGS<0, 3, 0>
```

2. This example allocates and initializes two record variables of type `SIGNEDNUM` (this record template is defined in Example 2 of the preceding section). For floating-point numbers, the sign bit is 0 for positive values and 1 for negative values.

```
PLUSONE SIGNEDNUM <0, 7FH, 0>
MINUS16 SIGNEDNUM <1, 83H, 0>
```

# STRUC Directive

## Syntax

```
name STRUC  
  [field] storalloc  
  
  ...  
name ENDS
```

Where:

*name* is an identifier for the structure template; *name* must be unique within the module.

*field* is an identifier; *field* must be unique within the module.

*storalloc* is a DBIT, DB, DW, DD, DP, DQ, or DT storage allocation statement. The storage allocation statement may contain DUP clauses. *Storalloc* specifies the variable type of the corresponding field; it may also specify the default initial value of this field for all subsequently defined variables of type *name*.

## Discussion

The STRUC . . ENDS block defines a template named *name*. The template *name* defines a symbol table entry whose size equals the total number of bytes specified between STRUC and ENDS. Each *field* name is also defined in the symbol table, together with its attributes.

A structure field name represents the logical address (an offset) of this field within all structures of type *name*. A field has two attributes: offset and type. The offset of a field is the number of bytes from the start of the structure to the field. The field's type depends on the storage allocation (*storalloc*) statement used in the template.

Structure fields defined as contiguous variables of type BIT are concatenated into one or more bytes and zero-filled to the nearest byte boundary.

A question mark (?) can be used to allocate storage for non-BIT-type fields with undefined initial values. If a value is specified in the storage allocation statement, it becomes the default value for the field. This default can be overridden by the structure allocation statement described in the next section.

Fields defined with more than one *storalloc* specification (a list) and fields defined with DUP (?) have non-overridable default values.

The assembler supports up to 150 structure fields that are defined with uninitialized values and without nested DUPs.

## Examples

1. This example defines a structure for procedure parameters that would be allocated on the stack. The `EBP` register would point to the procedure's stack frame; its parameters could be accessed by name using the notation `[EBP].field`. The Examples in the next section include the dot operator.

See also: Dot operator, Chapter 5

```
THIS_PROC_PARAMS STRUC
    OLD_EBP DD ?
    RETURN DD ?
    PARAM1 DD ?
    PARAM2 DW ?,?
    PARAM3 DW ?,?
THIS_PROC_PARAMS ENDS
```

The symbol `THIS_PROC_PARAMS` enters the symbol table as a structure 20 bytes in length. The five symbols `OLD_EBP`, `RETURN`, `PARAM1`, `PARAM2`, and `PARAM3` are defined as structure fields. `OLD_EBP` has type `DWORD` and an offset of 0 within the structure; `RETURN` has type `DWORD` and an offset of 4. `PARAM1` has type `DWORD` and an offset of 8, `PARAM2` has type `WORD` and an offset of 12, and `PARAM3` has type `WORD` and an offset of 16 within the structure.

2. This example defines a 6-byte structure template for type `POINTER`.

```
POINTER STRUC
    OFFST DD ?
    SEGSEL DW ?
POINTER ENDS
```

3. This example defines a 16-byte structure template that represents a point on a plane expressed in polar coordinates.

```
POLARPOINT STRUC
    RADIUS DQ 0
    ANGLE DQ 0
POLARPOINT ENDS
```

# Structure Allocation Statement

## Syntax

```
[name] strucnm < [exp] [, ... ] >
```

Where:

- name* is an identifier that defines the logical address for a variable. The segment part of its logical address is the current segment and its offset is the current location counter; the binder can relocate the offset. *name* must be unique within the module.
- strucnm* is the name of a previously defined structure template. *Strucnm* is the variable's type; it specifies the variable's fields, their types, and a variable storage size equal to the number of bytes allocated by the template. *Strucnm* may be followed by a DUP clause.
- exp* is a value that overrides the default field value given in the template definition. *Exp* is a question mark (?) (except for fields of type BIT), a constant expression, or a string enclosed in single quotes ('). If it is not a ?, its value must fit in the type specified for the corresponding structure template field.

## Discussion

This statement allocates storage based on a structure template (see the preceding section). The amount of storage allocated will be the number of bytes defined in the template (multiplied by any DUP clauses).

Field values defined in the structure template are defaults. They may be overridden in the storage allocation statement with certain restrictions. The following rules must be observed for *exp*:

- To allocate a structure without overriding the default values, specify <> (no *exp* values).
- The default value specified in the structure template definition must be a ? (non-BIT fields only), a constant expression, or a character string used as a default value for a byte (DB) field. The overriding value must fit within the field.
- Template fields defined with more than one *storalloc* specification (a list) and template fields defined with DUP (?) may not be overridden.

- Assuming a structure with fields  $\langle f1, f2, f3, \dots, fn \rangle$ , specify a comma for each field with an acceptable default value and specify an overriding *exp* for each  $f_m$  to be overridden.

For example, use the following to override ( $f3$  and  $f4$ ) or  $fn$ , respectively:

```
<, , 2, 5>
<, , , . . . , 2>
```

After the last field to be overridden, commas need not be specified for remaining fields. In the first preceding example, commas must be specified only for  $f1$  and  $f2$  (the  $f5 . . fn$  default values are acceptable).

- A DB field initialized with a single string of two or more characters can be overridden only with another string. The overriding string need not be the same length as the template's. If the overriding string is shorter than the original string, the remaining characters of the original string are used. If the overriding string is longer but still fits in the field, the overriding string is used. Otherwise, the assembler generates an error.

## Examples

1. This example allocates storage for a structure of type `THIS_PROC_PARAMS` (this structure template is defined in Example 1 of the preceding section).

```
APROC THIS_PROC_PARAMS <>
```

To access a field of `APROC`, use the dot operator (e.g., `APROC.PARAM1`).

However, a structure field is not irrevocably tied to the structure in which it is defined. `[EBP].PARAM2` could be used in any context where you wanted a `BYTE` variable that was offset by 4 bytes from the `EBP` base. It is not necessary (and the assembler does not check) that the surrounding data pointed to by `EBP` follows the template format defined for `THIS_PROC_PARAMS`. Assuming that `EBP` has already been set to point to the beginning of this structure, `APROC` parameters can be accessed as `[EBP].PARAM1`, `[EBP].PARAM2`, and `[EBP].PARAM3`.

2. This example allocates storage for and initializes a structure of type `POLARPOINT` (this structure template is defined in Example 3 of the preceding section). This structure is initialized with radius 2.0 and angle 3.1416, overriding the template's specification (uninitialized storage for the field values).

```
VALUE1 POLARPOINT<2.0, 3.1416>
```

To perform any calculations using `VALUE1`, refer to the fields of this structure as `VALUE1.RADIUS` and `VALUE1.ANGLE` in the instruction.

3. This example allocates storage for an array of 20 structures of type POLARPOINT, each initialized with the same two data values.

```
POLPT_ARR1 POLARPOINT 20 DUP (<2.0,3.1416>)
```

4. This example defines a structure template with overridable fields, and allocates storage for a variable that overrides the default STRUC values.

```
OVERRIDABLE STRUC
  ASTRING      DB 'ABCDEFGG'
  DONTCARE DW ?
  AREAL        DD 3.14159
OVERRIDABLE ENDS
VARO OVERRIDABLE <'HIJ',1,1E-23>
```

5. This example defines a structure template with fields that may **not** be overridden (see the Discussion section).

```
NONOVERRIDE STRUC
  ALIST DB 1,2,3          ; cannot override list
                          ; of default values
  ADUP DW 10 DUP (?)     ; cannot override defaults
                          ; specified with DUP
NONOVERRIDE ENDS
```

6. These equations illustrate results when multiple dot operators are used in an expression. Given the following structure template definitions and address expression using the dot operator:

```
FOO STRUC
  FE DB 0                ; offset from FOO = 0
  FI DW 0                ; offset = 1
FOO ENDS

BAA STRUC
  FO DB 0                ; offset from BAA = 0
  FUM DD 0               ; offset = 1
BAA ENDS
```

```
[EBP].FE.FI.FO.FUM =
[EBP] + 0 + 1 + 0 + 1 = [EBP] + 2
```

The result's type is the same as the rightmost field specification, `DWORD` (=FUM's in this example). However, the result's type can be overridden with the `PTR` operator as follows:

```
WORD PTR [EBP].FE.FI.FO.FUM
```

The `PTR` expression has the same value as `[EBP].FE.FI.FO.FUM`, but type `WORD`.

See also: `PTR` operator, Chapter 5

## DUP Clause

A `DUP` clause reserves storage for a sequence of variables of a single type. Use `DUP` with any `DBIT`, `DB`, `DW`, `DD`, `DP`, `DQ`, or `DT` storage allocation statement to define an array-like variable. Such a variable's elements can be accessed as multiples of a constant offset from the initial element; the constant value equals the size of the element type. Use `DUP` with any record or structure allocation statement to allocate contiguous storage for an array-like variable whose elements are records or structures.

## Syntax

```
rep-val DUP (val[, ...])
```

Where:

*rep-val* specifies the number of storage units to be allocated. A storage unit is one of the following: `BIT`, `BYTE`, `WORD`, `DWORD`, `PWORD`, `QWORD`, `TBYTE`, or previously specified (named) record or structure template.

*val* is any initialization expression (*init* or *exp*) that is valid for the specified storage unit, or it is another `DUP` clause.

## Discussion

`DUP` allocates storage for and optionally initializes an array-like variable with elements of a single type. `DUP` is an optional part of any storage allocation statement, including a record or structure allocation statement. For a variable allocated with `DBIT`, `DB`, `DW`, `DD`, `DP`, `DQ`, or `DT`, specify a `DUP` clause as follows:

```
[name] dtyp rep-val DUP (init[, ...])
```

For a variable allocated with a record or structure template name, specify a `DUP` clause as follows:

```
[name] recnm rep-val DUP (<[exp] [, ...]>)
```

or

```
[name] strucnm rep-val DUP (<[exp] [, ...]>)
```

For non-`BIT`-type variables, `DUP` can be used to reserve storage space without producing a data initialization record in the object module. The syntax

```
rep-val DUP (?)
```

reserves storage space with undefined values. The amount of reserved space depends on the *rep-val* specified and the storage allocation size specified by the directive or template that precedes `DUP`.

The assembler allows `DUP` clauses to be nested up to the limit of the symbol table memory space for simple types. For structure types, this limit is less than 150. The assembler fills `DUP (?)` specifications within a structure with zeros.

The assembler fills any other `DUP (?)` storage allocations with zeros when an initialization value is specified in the storage allocation statement. Specify `?` for every initialization value when you want totally undefined storage in the object file. However, variables defined with `DBIT` may not be initialized with the question mark.

## Examples

1. These examples use `DUP` to initialize bit patterns.

```
THE_BITS DBIT 2 DUP (10b)          ; initializes 2 bytes
                                       ; at THE_BITS to
                                       ; 00000010
                                       ; 00000010
BIG_BITS DBIT 4 DUP (11011B)      ; initializes 4 bytes
                                       ; at BIG_BITS to
                                       ; 00011011
                                       ; 00011011
                                       ; 00011011
                                       ; 00011011
```

2. This example initializes 50 bytes; each group of five bytes contains the value 48454C4C4FH.

```
BYTES1 DB 10 DUP ('HELLO')
```

3. This example initializes 400 bytes.

```
ADDEXPS DW 100 DUP (1,0FFFFH,15,10101010B)
```

4. These examples initialize 420 bytes and reserve 40 bytes of uninitialized storage.

```
MANYDUPED DB 3 DUP (4 DUP (5 DUP (1, 6 DUP (0) ) ) )
NOINIT DD 10 DUP (?)
```

5. This example allocates contiguous storage for an array of 20 structures of type `POLARPOINT`. Each structure is initialized with the same two data values.

```
POLPT_ARR1 POLARPOINT 20 DUP (<2.0,3.1416>)
```

See also: `POLARPOINT`, Example 3 of the `STRUC` directive, in this chapter

# Labels

A label is a name that defines a logical address within an assembler program:

- The location counter is a predefined label that keeps track of the current offset within a segment being assembled. The `ORG`, `EVEN`, and `ALIGN` directives control the location counter.
- The `LABEL` directive creates a name for the current location of assembly in code or data segments.
- A labeled instruction in the code segment might be the target of a `JMP` or conditional jump instruction. If both the jump and labeled instructions are in the same segment, the (NEAR) label can be a name followed by a colon (`:`) that immediately precedes the target. The `LABEL` directive must be used to define a `FAR` label (the labeled target instruction is not known to be in the same segment as the jump instruction). The `LABEL` directive may also be used to define a `NEAR` label.
- A labeled sequence of instruction(s) in the code segment might be the target of a `CALL` instruction. The `PROC` directive defines a `NEAR` or `FAR` label for such an instruction sequence. The target sequence is usually interpreted as a subroutine or procedure.

Labels in code segments can be operands of the `CALL`, `JMP`, and conditional jump instructions.

See also: `CALL`, `JMP`, and conditional jump instructions, Chapter 6

## Label Attributes

A label has four attributes:

**Segment**     The in which it was defined

**USE**            The `USE` attribute (`USE32` or `USE16`) of the segment in which it was defined: this determines the size of the label's logical address.

**The label's offset**

This is the label's distance from the base of its defining segment.

Offset is a 32-bit value for labels in `USE32` segments and a 16-bit value for labels in `USE16` segments.

**The label's type**

For labels in a data segment, this is the type of the target location (a variable or defined storage location). For labels that target code, the type indicates the kind of jump or `CALL` that will be made to the location it represents. These two types are as follows:

- Type `NEAR` represents a label that can be accessed by a jump or call that lies within the same physical segment. This kind of access is called an intrasegment jump or call. The logical address defined by a `NEAR` label is a simple offset within the same segment.
- Type `FAR` represents a label that can be accessed from another segment. This kind of access is called an intersegment jump or call. Because control is transferred from one segment to another, the contents of the `CS` register must be changed when the jump or call occurs. The logical address defined by a `FAR` label is a 16-bit segment selector with 32-bit offset. The `JMP`, conditional jump, or `CALL` instruction will load this address into `CS:EIP` when it executes.

## The Location Counter

The location counter is a predefined label represented by the symbol `⋄`. The value of the location counter is the current offset within the segment being assembled. The location counter has the following attribute values:

- Segment -- current segment
- Offset -- current offset
- USE -- current segment's
- Type -- NEAR

The `⋄` may be used as an operand of instructions or expressions. The assembler will maintain the correct offset within a segment even if the segment is repeatedly opened and closed in the module with `SEGMENT . . ENDS` pairs.

See also: `SEGMENT . . ENDS` pairs, Chapter 2

Three directives control the location counter

|                    |                                                                                               |
|--------------------|-----------------------------------------------------------------------------------------------|
| <code>ORG</code>   | Sets the counter to a specified value.                                                        |
| <code>EVEN</code>  | Sets the location counter to the next dword or word.                                          |
| <code>ALIGN</code> | Sets the location counter to the next value that is evenly divisible by the specified number. |

## ORG Directive

### Syntax

```
ORG exp
```

Where:

*exp* is a constant expression or a label that is evaluated to a number in the range of 0 to  $2^{32} - 1$  (4 gigabytes) in USE32 segments or in the range of 0 to 65536 in USE16 segments.

### Discussion

Use the `ORG` directive to control the location counter value. An `ORG` expression locates code or data at a specified offset within the current segment.

### Examples

These examples use the value of the current location counter as an operand. The first example sets the location counter to a value 1000 bytes beyond the current location. The second example overwrites the just assembled 1000 bytes.

```
ORG OFFSET($ + 1000)
:
ORG OFFSET($ - 1000)
```

## EVEN Directive

### Syntax

```
EVEN
```

### Discussion

The `EVEN` directive ensures that the location counter is a dword or word boundary for subsequent code or data.

The assembler inserts (if necessary) up to three `NOPS` (90H) following `EVEN` to align subsequent code to the nearest dword (for USE32 segments) or word (for USE16 segments). In the data segment, the `EVEN` directive pads with zeroes to align subsequent data to the nearest dword (for USE32 segments) or word (for USE16 segments).

## ALIGN Directive

### Syntax

```
ALIGN [exp]
```

Where:

*exp* is any nonrelocatable constant expression that evaluates in the range 1 to 256. The `ALIGN` directive aligns subsequent code or data on an offset that is evenly divisible by the specified number of bytes.

### Discussion

The `ALIGN` directive sets the location counter to the specified boundary for the subsequent alignment of code or data.

The assembler inserts `NOP` instructions (90H) if necessary to align subsequent code to the specified boundary. When used in a data segment, the assembler pads to the specified boundary with zeroes.

If *exp* is omitted, the default is 4-byte, or `DWORD`, alignment.

For example, the following directive causes paragraph (16-byte) alignment:

```
ALIGN 16
```

As another example, the following directive causes page (256-byte) alignment:

```
ALIGN 256
```

# LABEL Directive

## Syntax

*name* LABEL *type*

Where:

*name* is an identifier; name must be unique within the module.

*type* is NEAR or FAR, a variable type (BIT, BYTE, WORD, DWORD, PWORD, QWORD, or TBYTE), a label name, a record template name, or structure template name. Label, record, and structure names cannot be forward references.

## Discussion

LABEL creates a name for the current location of assembly, whether data or code. Use LABEL to define a variable or a label that has the following attributes:

- The segment that is currently being assembled
- The current offset within that segment
- The USE attribute of the current segment
- The specified type

Labels of type FAR must be defined with the LABEL directive. NEAR labels need not be defined with LABEL but they can be. NEAR- and FAR-type labels may not be overridden.

See also: Attribute override operators, Chapter 5

It is possible use LABEL to alias a FAR label to a NEAR label. However, aliased labels of opposite types can be used only as JMP or conditional jump operands. It is an error to CALL the same procedure twice with aliased NEAR and FAR labels if a return from the procedure is expected. The RET instruction coded within a procedure is either near or far; it cannot be both.

## Examples

1. This example allows two consecutive bytes to be accessed both as a `WORD` and as two different `BYTES`.

```
AWORD LABEL WORD
LOWBYTE DB 0
HIGHBYTE DB 0
```

2. This example sets up three ways of accessing the same data location. `BIT_ARRAY`, `TBYTE_ARRAY`, and `WORD_ARRAY` all refer to the same data locations as `BYTE_ARRAY`; they provide alternate forms of addressing it.

```
BYTE_RECORD RECORD B7:1,B6:1,B5:1,B4:1,
& B3:1,B2:1,B1:1,B0:1

BIT_ARRAY LABEL BYTE_RECORD
TBYTE_ARRAY LABEL TBYTE
WORD_ARRAY LABEL WORD

BYTE_ARRAY DB 100 DUP (0)
```

3. This example shows both `NEAR` and `FAR` labels at the same code location. Even though there is a `CALL` at this location, this example will not cause an error. The `ABORT_MESSAGE` routine does not return to the location that jumped to `ABORT_FAR` or `ABORT_NEAR`.

```
ABORT_FAR LABEL FAR
ABORT_NEAR:
CALL ABORT_MESSAGE
JMP EXIT ; do not RET to caller
```

# Defining Implicit NEAR Labels

## Syntax

```
lblname: [instruct]
```

Where:

*lblname* is an identifier; *lblname* must be unique within the module.

*instruct* is an instruction.

## Discussion

A label within the same segment is merely a name followed by a colon (:). Such a label has the following attributes:

- The current segment being assembled
- The label's offset (the current value of the location counter)
- The current segment's USE attribute
- The default label type, NEAR

If no target instruction is specified, a jump to the label causes the instruction following the label to be executed. This form of label is equivalent to the following:

```
lblname LABEL NEAR
```

## Example

```
ALAB: MOV EAX, COUNT
```

# PROC Directive

## Syntax

```
name PROC [type] [WC (exp) ]  
      : :  
name ENDP
```

Where:

- name* is an identifier; *name* must be unique within the module.
- type* is NEAR or FAR. NEAR is the default.
- exp* is the number of dwords (USE32 segment) or words (USE16 segment) of parameters to be transferred to the more privileged stack during an interlevel call. *Exp* must evaluate to an integer in the range 0..31.

## Discussion

PROC defines a label for a sequence of instructions that are interpreted as a subroutine or procedure of type NEAR (called from within the same segment) or FAR (called from another segment).

The type specified with PROC tells the assembler whether to generate a near or far RET instruction for the procedure operand. A RET (return) instruction coded between PROC . . ENDP has the same type (near or far) as its enclosing routine. It is an error if paired CALL-RET instructions have mismatched near/far attributes.

If PROCLEN is specified between PROC . . ENDP, it returns 0FFH if the procedure is of type FAR. PROCLEN returns 0 for all other cases.

See also: PROCLEN, Chapter 9

The assembler allows procedures to be nested. However, nested procedures do not behave like nested procedures in some high-level languages:

- The assembler does not have scope rules for programmer-defined names. Every variable and label in a module must have a unique identifier.
- The assembler is not a block-structured language. A nested procedure is coded within the instruction sequence of another routine. Unless the containing routine jumps around the nested procedure, the nested procedure will execute when its containing routine executes. Furthermore, a nested procedure may cause some of the containing routine's code to be skipped because a RET from the nested procedure also causes a return from its containing routine (see Example 3).

## Examples

1. The assembler has both near and far `CALL` and `RET` instructions. Whether a `CALL` is near or far depends on the type of its procedure operand. The following is an example of a `NEAR` procedure with its appropriate call.

```
LOCALCODE SEGMENT ER PUBLIC
ANEARPROC PROC NEAR
    : : ; some code
    RET ; near return
ANEARPROC ENDP
    : :
CALL ANEARPROC ; near call
    : : ; (intrasegment)
LOCALCODE ENDS
```

2. This example shows a `FAR` procedure and its call.

```
GLOBALCODE SEGMENT ER
AFARPROC PROC FAR
    : : ; some code
    RET ; far return
AFARPROC ENDP
GLOBALCODE ENDS
    : :
SPECSEG SEGMENT ER
CALL AFARPROC ; far CALL
    : : ; (intersegment)
SPECSEG ENDS
```

3. When one procedure is defined within another, execution can fall into the nested procedure.

```
P1 PROC NEAR
    :
    MOV AX, 15                ; execution begun here will
continue                    ; continue
    ADD DX, AX                ; through to the second MOV
AX, 0
    P2 PROC NEAR
        MOV AX, 0
        CMP AX, COUNT
        JE LAB
        DEC COUNT
        :
        LAB:
        MOV AX, 0
        RET                  ; exit P1 and P2 here
    P2 ENDP                  ; remaining statements
    CMP DX, 10               ; will never be executed
    JE LAB
    RET
P1 ENDP
```

## Using Symbolic Data

Assembler label and variable names are symbolic data. All programmer-defined identifiers referenced in assembler programs are symbolic data. Assembler keywords and reserved words are symbols, as well.

See also: Assembler keywords and reserved words, Appendix C

Both labels and variables define logical addresses that represent values. A label identifier's value is the logical address it defines. A variable identifier's value is the contents of the logical address it defines.

The `EQU` directive assigns new names to symbols. The `PURGE` directive directs the assembler to omit object file information about particular `EQU`ated symbols and programmer-defined symbols.

# EQU Directive

## Syntax

*name* EQU *value*

Where:

*name* is an identifier; *name* must be unique within the module.

*value* is a variable or label name, a constant or register expression, a processor register, a floating-point stack element, a mnemonic, or instruction prefix, a codemacro call or prefix, or the operators NOT, AND, OR, XOR, SHL, or SHR. *value* can be any address expression.

See also: Floating-point stack elements, Chapter 7  
mnemonics, Chapters 6 and 7  
instruction prefixes, Chapter 6  
codemacro calls or prefixes, Chapter 9  
address expressions, Chapter 5

## Discussion

EQU assigns a value to an identifier. In effect, EQU creates either:

- An alias for a symbol's value
- An identifier for an assembly-time constant or run-time expression value.

If the assigned value is a variable or label name, it can be forward referenced. The EQU directive defines another pointer to such a variable or label. However, the assigned value may not be an expression that contains a forward reference.

A global integer constant can be created by specifying the EQUated name in a PUBLIC statement. The value of such a global constant must be in the range:

- $-2^{31} \dots (2^{31}-1)$  in USE32 segments
- $-32,768 \dots 32,767$  in USE16 segments

The precision of an EQUated real expressed in decimal notation is determined in context. The name equated to these values can initialize data of more than one type. Floating-point numbers expressed in hexadecimal real notation also may be used as EQU values. However, the names equated to these values can only be used to initialize data of a single type.

Register expression values can include a segment override.

See also: PUBLIC statement, Chapter 3  
DD, DQ, and DT directives, in this chapter

## Examples

1. This example makes a forward reference to a value represented by the label ALAB.

```
ALABEL EQU ALAB
ALAB:MOV EAX, 0
```

2. This example defines aliases for processor registers.

```
COUNT EQU ECX
PNTR EQU EBX
MOV COUNT, 10           ; ECX = 10
MOV PNTR, OFFSET ARRAY ; EBX = offset of array
```

3. This example defines aliases for the MOV and INC instructions.

```
DATAMOVE EQU MOV
INCREMENT EQU INC
DATAMOVE EAX, EBX
INCREMENT EAX
```

4. These examples illustrate integer and floating-point constant value specifications. A floating-point constant specified in decimal can initialize data of more than one type; the precision of such values is determined in context. A floating-point constant specified in hexadecimal real can initialize a single type of data (DWORD, QWORD, or, as here, TBYTE).

```
TOTAL EQU 6
PI EQU 3.141592653589793
DD PI           ; single precision
DQ PI           ; double precision
DEG_TO_RAD EQU 3FF98EFA351294E9C8AER ; PI / 180
DT DEG_TO_RAD  ; extended precision
```

5. This example illustrates assembly-time initializations.

```
E1 EQU 2 + 3
E2 EQU E1 AND 4
E3 EQU (E1-E2) / 12
```

6. This example uses EQU to define variables to be accessed on the stack.

```
STKWRD EQU WORD PTR [EBP+2]
ONEVAR EQU SS:[EBX+3]
TWOVAR EQU SS:[EBX]
```

# PURGE Directive

## Syntax

```
PURGE name [, ...]
```

Where:

*name* is a symbolic data identifier.

## Discussion

PURGE deletes the definition of one or more specified symbols. Labels, variables, and keyword or register aliases defined with EQU can be purged.

The following kinds of symbols cannot be purged:

- Names declared PUBLIC
- Register names
- Assembler reserved words

See also: PUBLIC names, Chapter 3  
Assembler reserved words, Appendix C

A purged symbol remains undefined unless it is redefined. A reference to a symbol after it has been purged but before it is redefined constitutes a forward reference to the redefinition. If no redefinition occurs, such a reference is an error.

A PURGE coded just before the program END statement causes the assembler to delete object file symbol information about purged symbols.

## Examples

1. This example deletes aliases (defined with EQU) for an assembler instruction and a processor register.

```
DATAMOVE EQU MOV  
COUNT EQU ECX  
: :  
PURGE DATAMOVE, COUNT
```

2. For the variable and label specified in this example, the assembler will omit symbol information from the object file for the module.

```
PURGE ALABEL, VAR1  
END ; module
```





# Accessing Data 5

---

This chapter contains four major sections:

- Overview of assembler expressions

This section introduces constant and address expressions.

- Operators

This section explains the assembler isolation, multiplication and division, shift, addition and subtraction, relational, logical, attribute value, attribute override, and record specific operators.

- Instruction Operands

This section summarizes the operands to assembler instructions.

- Memory Addressing Methods

This section explains the forms of assembler address expressions in detail.

## Overview of Assembler Expressions

Expressions contain operands and operators. An assembler expression specifies either:

- A value that initializes data. Such a value must be a constant expression, an external constant, or a relocatable address expression.
- Or, an address in memory that may be an instruction operand. This is sometimes called an address expression.

Constant expressions specify values that are known at assembly time. Address expressions specify values that might not be known at assembly time; they represent an address that will be accessed during program execution on the processor. The contents at such an address might be modified during program execution.

For an assembler instruction to operate on data, the data must be accessible as an instruction operand. Some instructions have implicit operands such as registers. However, most instructions require explicit operand(s). An instruction operand can be expressed as a register, a constant, a location in memory, or as a combination of these components.

Some operands can be specified as expressions consisting of a series of variable names, base and index registers, and constants combined by operators. For example, the contents of a register and a constant could be added with the addition operator.

There are many assembler operators that can be used to create expressions.

## Constant Expressions

Constants (see Table 4-2) can be used as expression operands with most assembler operators (see Table 5-1). The storage allocation directives (described in Chapter 4) initialize data values using constant expressions. Constant expressions yield a value that is known at assembly time.

However, a symbolic constant defined in another module has an unknown value at assembly time. When modules are combined, such a constant's value replaces each external reference to the constant. For example:

```
EXTRN ANUMBER:ABS
DATA SEGMENT
AWORD DW ANUMBER      ; AWORD gets value of ANUMBER
                        ; when modules combined
DATA ENDS
```

External symbolic constants do not form constant expressions.

See also: `PUBLIC` directive, Chapter 3

## Address Expressions

An address expression defines a location in memory. This location can be interpreted as either a variable or label, depending on the expression used. Every address expression has a simple type (`BIT`, `BYTE`, `WORD`, `DWORD`, `PWORD`, `QWORD`, `TBYTE`, `NEAR`, or `FAR`). The rules for address expression formation preclude mixing variable or label types unless the `PTR` operator coerces uniformity of type.

See also: `PTR` operator, in this chapter

## Variable and Label Names as Address Expressions

The simplest address expression is the name of a variable or label. In this case, the name implies addressing using the variable's or label's offset from its defining segment's base address. This address is relocatable.

For example:

```
ADD DX,COUNT      ; COUNT is a simple address expression

ADD DX,COUNT + 2  ; In this case, address expression has
                  ; the same segment and type as COUNT
                  ; but has an offset that is 2 greater
```

## Register Expressions

A register expression is an address expression that uses a base and/or an index register. Possible forms are:

```
[base-reg] or [index-reg * scale]
[base-reg + index-reg * scale]
[base-reg + disp] or [index-reg * scale + disp]
[base-reg + index-reg * scale + disp]
```

Where:

*base-reg* is any 32-bit general register (EAX, ECX, EDX, EBX, ESP, EBP, ESI, EDI) for 32-bit addressing, and is BX or BP for 16-bit addressing.

*index-reg* is any 32-bit general register except ESP for 32-bit addressing, and is SI or DI for 16-bit addressing.

*scale* is (an optional) constant or constant expression that evaluates to 1, 2, 4, or 8 for 32-bit addressing. It is invalid for 16-bit addressing.

*disp* is an 8- or 32-bit displacement for 32-bit addressing, and is an 8- or 16-bit displacement for 16-bit addressing.

At assembly time, a simple register expression operand is called an anonymous reference. The data addressed by a named register has no explicit type (BIT, BYTE, WORD, DWORD, PWORD, QWORD, TBYTE, or record/structure template name).

For a two-operand instruction with one register operand, the assembler determines the type of an anonymous reference from the size of the register. For example:

```
MOV CX, [BX]      ; move WORD data pointed to by BX into CX
```

For all other kinds of anonymous references, the PTR operator must be used to specify a type. For example:

```
MOV WORD PTR [DI], 5      ; assign 2 bytes
INC BYTE PTR [BX]+2      ; increments 1 byte
```

## Combining Simple Address and Register Expressions

Register expressions can be combined with simple address expressions to form a more complex address. The form is:

```
varname [reg-exp]
```

Where:

*varname* is the name of a variable.

*reg-exp* is a register expression (see the preceding section) enclosed in brackets.

The register expression implies that the address of the operand will be computed from the run-time contents of the register. For example:

```
COUNT[EBX]          ; simple base
COUNT[EBX] + 2     ; base plus displacement
COUNT[EBX] + [ESI] ; base plus index
```

For the preceding examples, the offset of the variable COUNT will be added to the contents of the register(s) in the register expression.

See also: Implicit bracket addition, Addition and Subtraction Operators, in this chapter  
Processor registers and memory addresses, Appendix A

## Structure Fields in Address Expressions

Another form of address expression uses a structure field name as a displacement added to a structure's offset within its segment.

For a variable of a structure type, a field name represents an offset within the structure. The field name can be combined with a named variable of the same type as the field or with a register expression to form an address expression. Such an address expression has the following attributes:

- Its segment This is the same as the variable's, or it is the processor default for the register.
- Its offset This is the offset of the variable or register expression plus the offset of the field within the structure.
- Its type This is the type defined in the structure template for the field. If more than one structure field is specified, the rightmost field determines the address expression's type.

For example, consider the following structure definition and instruction results:

```
ASTRUC STRUCTURE
  ABYTE DB 0          ; offset = 0
  AWORD DW 0         ; offset = 1
  BYTE2 DB 0         ; offset = 3
ASTRUC ENDS
:
ANARRAY DB 1,2,3,4   ; ANARRAY.AWORD has type WORD
:
MOV AL,ANARRAY.BYTE2 ; AL := 4
MOV CX,ANARRAY.AWORD ; CX := 0302H
MOV BX,OFFSET ANARRAY ; BX holds offset
MOV AL,[BX].ABYTE    ; AL := 1 [BX].ABYTE has type BYTE
```

## Relocatable Expressions

Address expressions involving named variables, labels, and segments can have results that might not be known until all program modules have been assembled, combined, and located. Such expressions are called relocatable. The system utilities assign values to such address expressions.

The assembler automatically generates relocatable addresses for valid symbolic references in code segments.

See also: Relocatable and non-relocatable address generation, `ASSUME` directive, Chapter 2

The assembler also generates various kinds of relocatable addresses for symbolic references in data segments:

1. A segment name in an address expression represents the logical address of its selector. A segment name that is referenced in another data segment forms a base relocatable address. For example, `DATA1` is base relocatable in the following:

```
DATA1 SEGMENT
    :
DATA1 ENDS
DATA2 SEGMENT
    SEGBASE DW DATA1    ; SEGBASE contains base
                    ; relocatable address of DATA1
    :
DATA2 ENDS
```

2. A variable or label name in a data segment address expression forms an offset relocatable address under either of the following conditions:
  - The variable or label is defined in a `USE32` segment and its name is used to initialize a variable of type `DWORD`.
  - The variable or label is defined in a `USE16` segment and its name is used to initialize a variable of type `WORD`.

For example, `ABYTE + 2` forms an offset relocatable address in the following:

```
DATA SEGMENT USE32
    ABYTE DB 0
    AN_OFFSET DD ABYTE + 2 ; AN_OFFSET contains offset
                    ; relocatable address of
DATA ENDS                    ; ABYTE + 2
```

3. A variable or label name in a data segment address expression forms a pointer relocatable address under either of the following conditions:
  - The variable or label is defined in a `USE32` or `USE16` segment and its name is used to initialize a variable of type `PWORD`.
  - The variable or label is defined in a `USE16` segment and its name is used to initialize a variable of type `DWORD`.

For example, `ABYTE` forms a pointer relocatable address in the following:

```
DATA SEGMENT USE32
  ABYTE DB 0
  A_POINTER DP ABYTE          ; A_POINTER contains pointer
                               ; relocatable address of ABYTE
DATA ENDS
```

Expressions with external constant operands also have results that are unknown at assembly time; the value of an `EXTRN:ABS` constant is supplied when modules are combined. Any address expression with symbolic operands might have results that cannot be determined until the program is located. The system utilities must supply these values.

For these reasons, there are restrictions on the use of relocatable expressions with some operators. These restrictions are noted in the operator descriptions in the following sections.

# Operators

Table 5-1 summarizes the assembler operators. These operators are explained in detail later in this section.

**Table 5-1. Assembler Operators**

| Operator                         | Description                                                                                                                                                                                                                                                                                                                                          |
|----------------------------------|------------------------------------------------------------------------------------------------------------------------------------------------------------------------------------------------------------------------------------------------------------------------------------------------------------------------------------------------------|
| HIGHW<br>LOW<br>HIGH<br>LOW      | <b>Isolation Operators (1 Operand)</b><br>Returns high-order word of dword operand<br>Returns low-order word of dword operand<br>Returns high-order byte of word operand<br>Returns low-order byte of word operand                                                                                                                                   |
| *<br>/<br>MOD                    | <b>Multiplication and Division (2 Operands)</b><br>Multiplies one operand by another<br>Divides one operand by another<br>Takes the modulus                                                                                                                                                                                                          |
| SHR<br>SHL                       | <b>Shift Operators (1 Operand)</b><br>Shift operand bits right<br>Shift operand bits left                                                                                                                                                                                                                                                            |
| +<br>-                           | <b>Addition and Subtraction (2 Operands)</b><br>Adds operands<br>Subtracts one operand from another                                                                                                                                                                                                                                                  |
| EQ<br>NE<br>LT<br>LE<br>GT<br>GE | <b>Relational Operators (2 Operands)</b><br>If operands equal, returns -1; otherwise, 0<br>If operands not equal, returns -1; otherwise, 0<br>If 1st operand < 2nd, returns -1; otherwise, 0<br>If 1st operand <= 2nd, returns -1; otherwise, 0<br>If 1st operand > 2nd, returns -1; otherwise, 0<br>If 1st operand >= 2nd, returns -1; otherwise, 0 |
| OR<br>XOR<br>AND<br>NOT          | <b>Logical Operators (2 Operands, except NOT)</b><br>If either operand's bit = 1, result bit = 1; otherwise, 0<br>If operands' bits different, result bit = 1; otherwise, 0<br>If both operands' bits = 1, result bit = 1; otherwise, 0<br>If operand bit = 1, result bit = 0, and vice versa                                                        |

continued

**Table 5-1. Assembler Operators (continued)**

| <b>Operator</b>   | <b>Description</b>                                                                           |
|-------------------|----------------------------------------------------------------------------------------------|
|                   | <b>Attribute Value Operators (1 Operand)</b>                                                 |
| THIS              | Defines variable or label at current assembly location                                       |
| SEG               | Returns segment selector of specified variable or label                                      |
| OFFSET            | Returns offset of variable or label                                                          |
| BITOFFSET         | Returns bit offset of bit variable                                                           |
| LENGTH            | Returns number of storage units allocated for variable                                       |
| TYPE              | Returns encoded value for variable or label type                                             |
| SIZE              | Returns number of bytes allocated for variable                                               |
| STACKSTART        | Returns offset of first (d)word above stack segment                                          |
|                   | <b>Attribute Override Operators (1 Operand)</b>                                              |
| <i>Sreg:</i>      | Overrides default segment attribute of a variable or label                                   |
| PTR               | Overrides variable's or label's type                                                         |
| SHORT             | Specifies that forward-referenced label is within 127 bytes of the end of a jump instruction |
|                   | <b>Record Specific Operators (1 Operand)</b>                                                 |
| MASK              | Masks specified field with 1's                                                               |
| <i>ShiftCount</i> | Shifts bits in record by size of specified field                                             |
| WIDTH             | Returns number of bits in record or field                                                    |

## Operator Precedence

Table 5-2 lists classes of assembler operators in decreasing order of precedence.

**Table 5-2. Assembler Operator Precedence**

| <b>Highest Precedence</b> |                                                                                                                                                                                      |
|---------------------------|--------------------------------------------------------------------------------------------------------------------------------------------------------------------------------------|
| 1.                        | Parenthesized expressions, angle-bracket (record) expressions, square-bracket expressions, the structure "dot" operator, and the operators LENGTH, SIZE, WIDTH, MASK, and STACKSTART |
| 2.                        | PTR, OFFSET, BITOFFSET, SEG, TYPE, THIS, and the segment override (CS:, DS:, ES:, FS:, GS:, or SS:)                                                                                  |
| 3.                        | HIGHW, LOWW, HIGH, and LOW                                                                                                                                                           |
| 4.                        | Multiplication, division, and shifts: *, /, MOD, SHR, SHL                                                                                                                            |
| 5.                        | Addition and subtraction: +, -<br>a. unary<br>b. binary                                                                                                                              |
| 6.                        | Relational: EQ, NE, LT, LE, GT, GE                                                                                                                                                   |
| 7.                        | Logical NOT                                                                                                                                                                          |
| 8.                        | Logical AND                                                                                                                                                                          |
| 9.                        | Logical OR and XOR                                                                                                                                                                   |
| 10.                       | SHORT                                                                                                                                                                                |
| <b>Lowest Precedence</b>  |                                                                                                                                                                                      |

Assembler expressions are evaluated from left to right following these precedence rules. If two operators with equal precedence are adjacent, the leftmost operator has precedence. Override this order of evaluation and/or operator precedence by using parentheses.

# Isolation Operators

## Syntax

```
HIGHW number32
LOWW  number32
HIGH  number16
LOW   number16
```

Where:

*number32* is a constant expression that evaluates to a 32-bit number.

*number16* is a constant expression that evaluates to a 16-bit number.

## Discussion

The HIGHW and LOWW operators return the high and low WORDS, respectively, of the 32-bit operand.

The HIGH and LOW operators return the high and low BYTES, respectively, of the 16-bit operand.

When applied to a WORD value, HIGHW returns 0. When applied to a BYTE value, HIGH returns 0.

## Examples

1. These examples contrast HIGH with LOW and HIGHW with LOWW as operators on the same values.

```
MOV AH, HIGH 1234H           ; AH := 12H
TENHEX EQU LOW 1234H        ; TENHEX := 34H

MOV AX, HIGHW 12345678H     ; AX := 1234H
MOV CX, LOWW 12345678H     ; CX := 5678H
```

2. These equations illustrate the results when HIGH/LOW and HIGHW/LOWW operator pairs are applied to each other.

```
HIGH LOW number = 0
HIGHW LOWW number = 0
LOW HIGH number = HIGH number
LOWW HIGHW number = HIGHW number
HIGHW HIGHW number = 0           ; HIGHW applied to WORD
LOW LOW number = LOW number
HIGHW HIGH number = 0           ; HIGHW applied to BYTE
```

3. These examples use more than one isolation operator in the same expression, with one expression in parentheses. Compare results for the first and second examples. The second example reverses the first example's operators.

```
MOV AL, LOW (HIGHW 12345678H)    ; AL := 34H
MOV AL, HIGHW (LOW 1234H)        ; AL := 0 because
                                  ; HIGHW applied to BYTE
MOV AL, HIGH (LOWW 12345678H)    ; AL := 56H
```

## Multiplication and Division Operators

### Syntax

**Multiplication:**     *operand* \* *operand*  
**Division:**           *operand* / *operand*  
**Modulo:**             *operand* MOD *operand*

Where:

*operand* is a constant expression.

### Discussion

Use these operators only with constant expressions.

The result of a multiplication, division, or modulo operation is always an absolute number. The result of a multiplication must be no greater than 32-bits, or an overflow error will occur.

### Examples

```
CMP AL, 2 * 4                   ; compare AL to 8
MOV CX, 123H / 16               ; CX := 12H
ADD AX, 102 MOD 4               ; AX := AX + 2
```

# Shift Operators

## Syntax

**Shift right:** *operand SHR count*

**Shift left:** *operand SHL count*

Where:

*operand* is a constant expression.

*count* is a constant expression that evaluates to an ordinal; *count* represents the number of bits the operand is to be shifted.

## Discussion

The shift operators cause a bit-wise shift of the operand; it is shifted *count* bits to the right or left. Bits shifted into the operand are 0s.

In effect:

- Shifts to the left multiply the operand by 2 to the power specified by *count*.
- Shifts to the right divide the operand by 2 to the power specified by *count*.

## Examples

```
MOV BX, 0FACBH SHR 4      ; BX := 0FACH
ADD AL, 111000B SHL 2     ; 11100000 added to contents of AL
```

```
MOV BL, (0FACBH AND 0111000B) SHR 3 ; BL := 001B
   ; (bits 3,4,5)
```

# Addition and Subtraction Operators

## Syntax

**Addition:**  $operand + operand$

**Bracket Addition:**  $primary [exp]$

**Subtraction:**  $operand - operand$

Where:

*operand* is a constant expression, or a variable or label defined in the current module in the same segment.

*primary* is a constant expression, an ordinal, the name of a record variable followed by a record initialization, a string, a simple type name, NEAR, FAR, or PROCLen, enclosed in brackets or parentheses. PROCLen within a PROC . ENDP returns the value 0FFH for a FAR procedure; otherwise, PROCLen returns 0.

*exp* is a constant expression.

## Discussion

Only constant expressions can be added or subtracted. The construct enclosed in brackets ([]) alters operator precedence and implies that an addition operator precedes the bracketed expression (see Example 2).

Variables, labels, or identifiers that have been EQUated to labels or variables cannot be added or subtracted unless they have been defined in the current module and are in the same segment.

## Examples

1. This example illustrates assembly-time expressions.

```
E1 EQU 12 + 3
E2 EQU E1
E3 EQU E1 - E2
```

2. These equations illustrate the brackets as an addition operator. The last expression is an error. The brackets operator implies addition before its enclosed expression; it does not imply addition after its enclosed expression.

```
ALABL [3 * 5] = ALABL + (3 * 5)
ALABL + (3 * 5) [3 * 5] = ALABL + (3 * 5) + (3 * 5)
ALABL [3 * 5] [3 * 5] = ALABL + (3 * 5) + (3 * 5)
ALABL [3 * 5] (3 * 5) ; = error
```

# Relational Operators

## Syntax

**Equal:**        *operand* EQ *operand*

**Not equal:**   *operand* NE *operand*

**Less than:**    *operand* LT *operand*

**Less than or equal:**  
                  *operand* LE *operand*

**Greater than:**  
                  *operand* GT *operand*

**Greater than or equal:**  
                  *operand* GE *operand*

Where:

*operands* are either both constant expressions, or they are both variable or label names that are defined in the current module and in the same segment.

## Discussion

A relational operation always returns a result of -1 for true and 0 for false.

Either the result is 32-bits or it is truncated to 8 or 16-bits, depending on the context.

## Example

```
MOV AL, 3 EQ 0                    ; AL := 00000000B (false)
MOV BX, 2 LE 15                  ; BX := 0FFFFH (true)
```

# Logical Operators

## Syntax

```
operand OR operand  
operand XOR operand  
operand AND operand  
NOT operand
```

Where:

*operand* is a constant expression.

## Discussion

Logical operators operate on individual bits of their operand(s) and return an absolute number. Each bit of the result depends on the corresponding bit(s) in the operand(s).

The functions performed by these operators are as follows:

- |     |                                                                                                                                                                                                    |
|-----|----------------------------------------------------------------------------------------------------------------------------------------------------------------------------------------------------|
| OR  | A result bit is 1 if corresponding operand bits are 1. A result bit is also 1 if either corresponding bit is 1. A result bit is 0 only if both operand bits are 0. OR is the logical inclusive or. |
| XOR | A result bit is 1 if the corresponding operand bits are different. A result bit is 0 if the operand bits are the same. XOR is the logical exclusive or.                                            |
| AND | A result bit is 1 only if both corresponding operand bits are 1. Otherwise, a result bit is 0.                                                                                                     |
| NOT | A result bit is the opposite of the operand bit. It is 1 if the operand bit is 0; 0 if the operand bit is 1.                                                                                       |

## Examples

1. This example XORs two absolute numbers into AX. & is the assembler continuation character.

```
MOV AX, 1111000011110000B
& XOR 0011001100110011B ; AX := 1100001111000011B
```

2. These equations illustrate the effects of the OR and XOR operators.

```
11110000B
OR 00110011B
= 11110011B
```

```
11110000B
XOR 00110011B
= 11000011B
```

3. This equation illustrates the effects of the AND operator.

```
11110000B
AND 00110011B
= 00110000B
```

4. This equation illustrates the effects of the NOT operator.

```
NOT 00110011B
= 11001100B
```

## Attribute Value Operators

`THIS`, `SEG`, `OFFSET`, `BITOFFSET`, `LENGTH`, `TYPE`, `SIZE`, and `STACKSTART` return numerical values for the attributes of a variable, label or segment. These operators do not change the attributes of their operands.

### THIS Operator

#### Syntax

```
THIS type
```

Where:

*type* can be `BIT`, `BYTE`, `WORD`, `DWORD`, `PWORD`, `QWORD`, `TBYTE`, `NEAR`, or `FAR`.

#### Discussion

The `THIS` operator defines a variable or label at the current location of assembly.

The variable's or label's segment attribute will be the current segment being assembled. Its offset will be the value of the current location counter. Specifying the location counter symbol (`$`) is equivalent to specifying `THIS NEAR`.

See also: Location counter, Chapter 4

A variable or label type is specified by the operand of this operator. Its usage is similar to that of the `LABEL` directive. `THIS` is used either in conjunction with the `EQU` directive (see the following Example) or as part of an operand to an instruction.

#### Examples

1. `THIS` can be used to define another name with an alternate type for the same data item.

```
AWORD EQU THIS WORD          ; defines label AWORD
                               ; at current location
BYTE1 DB 0
BYTE2 DB 0
```

2. This code is equivalent to the preceding example.

```
AWORD LABEL WORD
BYTE1 DB 0
BYTE2 DB 0
```

3. `THIS` may be part of an instruction operand.

```
MOV EAX, THIS DWORD
```

## SEG Operator

### Syntax

```
SEG varlab
```

Where:

*varlab* is the name of a variable or label.

### Discussion

The `SEG` operator returns the segment selector of the variable or label. The segment selector is a base relocatable quantity.

`SEG` is used:

1. To specify (with the `ASSUME` directive) the segment in which a variable or label is defined (see Example 1).
2. To store a selector in a variable or to initialize a segment register (see Example 2). The initialized segment register cannot be `CS`.

### Examples

1. This example tells the assembler that `DS` will hold the selector of the segment in which `COUNT` was defined. In this case, the expression, `SEG COUNT`, is a symbolic representation of the name of `COUNT`'s defining segment when `COUNT` has been defined in a segment of another module.

```
ASSUME DS:SEG COUNT
```

2. This example stores the segment selector for `COUNT` into `SETSTART` and initializes `DS` with `COUNT`'s segment selector.

```
SETSTART DW SEG COUNT
           ; store the selector for the segment
INIT:MOV AX, SEG COUNT
      MOV DS, AX      ; initialize DS with COUNT's segment
```

3. This example is equivalent to Example 2.

```
SETSTART DW SEG COUNT
INIT:MOV DS, SETSTART
```

## OFFSET Operator

### Syntax

```
OFFSET varlab
```

Where:

*varlab* is the name of a variable or label defined in the current module.

### Discussion

The `OFFSET` operator returns its operand's offset in bytes from the base of the segment in which the operand is defined. The value returned by `OFFSET` is a 32- or 16-bit number, depending on whether the segment is a `USE32` or `USE16` segment.

If the operand to `OFFSET` is a bit variable that is not within a structure, then it must be byte-aligned; the `OFFSET` value is the number of bytes from the beginning of the segment to the byte with which the bit is aligned. For bits within a structure, the `OFFSET` value is the number of bytes from the beginning of the segment to the nearest low byte boundary.

In most cases, the returned value is not set until bind time; it is a relocatable number. The `OFFSET` operator is used primarily to initialize variables or registers to be used for indirect addressing (see the Example).

### Example

Some assembler instructions explicitly use indirect addressing when accessing data. When coding these instructions, you must initialize a register to the offset value of the data you wish to access.

```
TRANSLATE:  
  MOV EBX, OFFSET ASCIITABLE  
  MOV AL, VALUE  
  XLATB          ; EBX points to translation table
```

## BITOFFSET Operator

### Syntax

```
BITOFFSET name.field
```

Where:

*name* is the name of a structure.

*field* is a field of type `BIT` within the structure.

### Discussion

The `BITOFFSET` operator returns the bit offset from the nearest lower byte address of a structure field of type `BIT`. Use the following expression to obtain a value equal to the number of bits from the beginning of the structure to a specific bit:

```
((OFFSET name.field) - (OFFSET name))*8  
+ BITOFFSET name.field
```

For a `BIT`-type variable defined outside of a structure, `BITOFFSET` always returns a 0, because such a bit will always be byte-aligned. `BITOFFSET` also returns a 0 for structure fields that are not of type `BIT`.

## Example

Although the `OFFSET` operator is not a required part of a `BITOFFSET` expression, `BITOFFSET` is intended for use with `OFFSET`.

```
TESTBIT STRUC
    TSTBIT0 DBIT 0B          ; structure templates
    TSTBIT1 DBIT 0B          ; can be defined
    TSTBIT2 DBIT 0B          ; outside a segment
    TSTBIT3 DBIT 0B
    TSTBIT4 DBIT 0B
    TSTBIT5 DBIT 0B
    TSTBIT6 DBIT 0B
    TSTBIT7 DBIT 0B
    TSTBIT8 DBIT 0B
    TSTBIT9 DBIT 0B
TESTBIT ENDS
```

These instruction statements contrast `OFFSET` and `BITOFFSET` assignments to `AX`.

```
DATA SEGMENT USE32
    :
    BITTSTVARS TESTBIT <>    ; assume offset 1001H
                                ; from data segment
DATA ENDS
    :
CODE SEGMENT EO                ; default USE32
    MOV AX, BITOFFSET BITTSTVARS.TSTBIT9    ; AX := 1
    MOV AX, OFFSET BITTSTVARS.TSTBIT9        ; AX := 1002H

    MOV AX, (((OFFSET BITTSTVARS.TSTBIT9)
& - (OFFSET BITTSTVARS)) * 8)
& + BITOFFSET BITTSTVARS.TSTBIT9            ; AX := 9
  ; expression yields number of bits
  ; from beginning of structure for TSTBIT9
```

## LENGTH Operator

### Syntax

```
LENGTH varname
```

Where:

*varname* is the name of a variable or structure field (without the dot operator).

### Discussion

LENGTH returns the number of storage units (BITS, BYTES, WORDS, DWORDS, QWORDS, or TBYTES) that have been allocated for its operand. For a BIT-type operand, LENGTH returns a value equal to the number of bits in the storage allocation. Use LENGTH to set a counter for a loop that accesses the elements of an array .

### Examples

These equations illustrate results for LENGTH.

```
ABYTEARRAY DB 1,2,3,4,5,6,7  
LENGTH ABYTEARRAY = 7
```

```
AWORDARRAY DW 150 DUP (0)  
LENGTH AWORDARRAY = 150
```

## TYPE Operator

### Syntax

```
TYPE varlab
```

Where:

*varlab* is the name of a variable, a structure field (without the dot operator), or a label.

### Discussion

The TYPE operator returns a value that represents the number of bytes occupied by the type of its operand. These values are listed in Table 5-3.

Note that TYPE applied to a label operand yields a negative value.

Use TYPE in instruction sequences where a pointer is to be incremented by the number of bytes occupied by the TYPE operand. Or, use TYPE for scaling operations.

**Table 5-3. TYPE Operator Results**

| Operand Type | Value Returned                     |
|--------------|------------------------------------|
| BIT          | *                                  |
| BYTE         | 1                                  |
| WORD         | 2                                  |
| DWORD        | 4                                  |
| PWORD        | 6                                  |
| QWORD        | 8                                  |
| TBYTE        | 10                                 |
| Structure    | number of bytes in structure       |
| Record       | number of bytes (1 to 4) in record |
| NEAR         | -1                                 |
| FAR          | -2                                 |

\* For a BIT-type variable, TYPE returns a value equal to the number of bytes allocated with DBIT. For BIT-type structure fields, TYPE returns 0 if the field has less than 8-bits; otherwise, TYPE returns 1. See also: Chapter 4

## Examples

1. This example increments ESI using the TYPE operator and loops to the next ARRAY element to be accumulated.

```

MOV EBX, OFFSET ARRAY
MOV ECX, LENGTH ARRAY
           ; LENGTH = number of elements
MOV ESI, 0           ; index into array
ALAB:ADD AX,[EBX] + [ESI] ; add element to AX value
      ADD ESI, TYPE ARRAY ; increment pointer by size
           ; of an array element

      LOOP ALAB

```

2. This example is functionally equivalent to Example 1.

```

MOV EBX, OFFSET ARRAY
MOV ECX, LENGTH ARRAY
           ; LENGTH = number of elements
MOV ESI, 0           ; index into array
ALAB:ADD AX,[EBX] [ESI * TYPE ARRAY]
           ; add element to AX value

      INC ESI
      LOOP ALAB

```

## SIZE Operator

### Syntax

```
SIZE varname
```

Where:

*varname* is the name of a variable or structure field (without dot operator).

### Discussion

The `SIZE` operator returns the number of bytes allocated for a variable. For a variable allocated with `DBIT` that does not end on a byte boundary, the result is rounded up by 1 byte. For `BIT`-type structure fields with less than 8-bits, `SIZE` returns 1; otherwise, `SIZE` returns the same value as `LENGTH`.

For non-`BIT`-type variables, `SIZE` returns a value that is related to the `LENGTH` and `TYPE` results according to the following identity:

$$\text{SIZE} = \text{LENGTH} * \text{TYPE}$$

### Examples

1. These equations illustrate results for `SIZE`.

```
ABYTEARRAY DB 1,2,3,4,5,6,7  
SIZE ABYTE ARRAY = 7
```

```
AWORDARRAY DW 150 DUP (0)  
SIZE AWORDARRAY = 300
```

```
ADWORDARRAY DD 1,2,3,4,5,6,7  
SIZE ADWORDARRAY = 28
```

2. This example initializes the variable `ASIZE` to 7 and assigns the value 300 to `AX`.

```
ABYTEARRAY DB 1,2,3,4,5,6,7  
AWORDARRAY DW 150 DUP (0)  
ASIZE DB SIZE ABYTEARRAY           ; ASIZE gets 7  
: :  
MOV AX, SIZE AWORDARRAY           ; AX := 300
```

## STACKSTART Operator

### Syntax

```
STACKSTART segname
```

Where:

*segname* is the name of the stack segment (defined with STACKSEG).

### Discussion

Use STACKSTART to initialize the stack pointer (E)SP. Because the processor stack grows downward, the initial stack pointer value equals the offset of the first dword (or word, depending on the stack use attribute) above the stack segment in memory.

### Example

```
STACK STACKSEG 100
:
MOV ESP, STACKSTART STACK
```

## Attribute Override Operators

Use the attribute override operators to respecify attributes, such as a variable's or label's segment or type. There are three kinds of attribute override operators:

- Segment overrides, used to override a default segment register or to specify an anonymous reference to a variable or label
- The PTR operator, used to override type
- The SHORT operator, used to override the type of a forward-referenced NEAR label

## Segment Override Operator

### Syntax

```
CS: varlab  
DS: varlab  
ES: varlab  
FS: varlab  
GS: varlab  
SS: varlab
```

Where:

*varlab* is a variable name, a label that is not of type NEAR or FAR, or an address expression.

### Discussion

This operation overrides the segment attribute of a variable or label. The explicit use of a segment override takes precedence over an ASSUME directive and over default segment register usage.

Use the segment override to specify a segment register as the segment part of a memory address. A segment override applies only to a single instruction. The ASSUME directive tells the assembler to generate necessary segment overrides for all subsequent instructions.

See also: ASSUME directive, Chapter 2

Use this operator to override the default segment register for operands that are (or contain) only base or index registers. Such operands (and expressions) are assumed to point to a variable. This usage is called an anonymous (or non-symbolic) reference.

Segment overrides cannot be specified for the default registers in the following cases:

- ES as the destination of a string operation
- SS for stack operations
- CS for instruction fetches

See also: Appendix A for a summary of the processor default segment selection rules

## Examples

1. This example compares the use of `ASSUME` and the segment override.

```
DATA SEGMENT
  ABYTE DB 0
DATA ENDS
:
:

CODE SEGMENT
  ASSUME DS:DATA
  MOV BL, ABYTE
      ; reference to ABYTE is covered by the ASSUME
  MOV BL, ES:ABYTE ; override default (DS)
      ; ASSUME not required for ABYTE reference
CODE ENDS
```

2. These examples make anonymous references. When the first `MOV` instruction executes, the `DS` (default) register is used. The second `MOV` instruction specifies that `EBX` points to data accessible through the `ES` register.

```
MOV BL, [EBX]
:
:
MOV BL, ES:[EBX]
```

The opcode for the second `MOV` will be preceded by a segment override prefix (byte) that forces the processor to use the `ES` register in order to calculate the physical address of the variable.

See also: Segment override opcode prefixes, Chapter 6

## PTR Operator

### Syntax

*type* PTR *exp*

Where:

*type* can be BIT, BYTE, WORD, DWORD, PWORD, QWORD, TBYTE, NEAR or FAR.

*exp* can be a variable name, a label name, an address or register expression, or an integer that represents an offset.

### Discussion

Use PTR to override the type assigned to a variable or label name, or to assign a type to an anonymous effective address expression such as [EBX] (see the Examples).

PTR assigns the *type* attribute specified on the left to the variable, label or number specified on the right. PTR also assigns segment and offset attributes to the variable or label specified on the right.

When *exp* is a constant expression, *type* must be preceded by a segment override. When the *type* is NEAR or FAR, a segment override may not be specified.

Table 5-4 summarizes segment and offset attribute assignments for the possible values of *exp*.

**Table 5-4. PTR Result Attributes**

| <b><i>exp</i> is</b> | <b>Segment</b>                    | <b>Offset</b>     |
|----------------------|-----------------------------------|-------------------|
| variable or label    | <i>exp</i> 's                     | <i>exp</i> 's     |
| number               | specified by segment override     | <i>exp</i> itself |
| anonymous reference  | default segment unless overridden | run-time value    |

## Examples

1. These examples increment a byte, word, and dword in memory.

```
INC BYTE PTR [BX]
INC WORD PTR [ESI]
INC DWORD PTR [EBX]
```

2. These examples move an immediate value to a byte, word, or dword in memory.

```
MOV BYTE PTR [EDI], 99
MOV WORD PTR [EDI], 99
MOV DWORD PTR [EDI], 99
```

3. This example jumps through two levels of indirection.

```
JMP PWORD PTR [EBX] ; EBX points to 4-byte offset
                    ; followed by 2-byte segment base
```

4. These examples pick up a word from a byte array and a byte from a word array.

```
FOOW DW 100 DUP (?)
FOOB DB 200 DUP (?)
:
:
ADD AL, BYTE PTR FOOW[101]
                    ; add low byte of 50th word to AL
ADD DX, WORD PTR FOOB[20]
                    ; add word at 21st byte to DX
```

5. This example accesses an anonymous variable at a given offset from a segment.

```
MOV AL, DS:BYTE PTR 5 ; move byte 5 of DS segment to AL
```

6. These examples override the type attributes of a word variable and a label.

```
MOV CL, BYTE PTR AWORD ; get 1st byte of variable
MOV DL, BYTE PTR AWORD + 1 ; get variable's 2nd byte
MOV AL, BYTE PTR APROC + 5 ; read a byte of program code
```

## SHORT Operator

### Syntax

```
SHORT labelexp
```

Where:

*labelexp* is a label or label expression defined within the same segment as the instruction being assembled.

### Discussion

The `SHORT` operator specifies that a label referenced by a `JMP` or conditional jump instruction is within the range of -128..127 bytes of the end of the instruction.

`SHORT` allows the assembler to check that the label is in this range and to generate the most compact code for complex label expressions.

When a single label is forward-referenced, the assembler optimizes the relative offset. However, complex forward references cannot always be optimized.

### Example

This example illustrates the use of `SHORT` to save bytes of code. It assumes a `USE32` segment.

```
JMP $+(FWDLAB - FWDLAB2)           ; 8 bytes
JMP SHORT $+(FWDLAB - FWDLAB2)     ; 3 bytes
:
:
FWDLAB:
:
:
FWDLAB2:
```

## Record Specific Operators

The `WIDTH` operator returns a result equal to the number of bits in a record or record field.

The `MASK` operator, together with a record field name used as a shift count, helps to isolate and access the fields within a record. This provides an alternative to defining `BIT`-type variables in order to isolate specific bits in a record.

### WIDTH Operator

#### Syntax

```
WIDTH record
```

or

```
WIDTH rec-field
```

Where:

*record* is the name of a record variable.

*rec-field* is the name of a record field.

#### Discussion

The `WIDTH` operator returns a value equal to the number of bits in either a record or a record field.

#### Example

```
REC1 RECORD F1:2, F2:4, F3:1
R1NUMBITS DB WIDTH REC1          ; byte initialized to 7
F2NUMBITS DB WIDTH F2            ; byte initialized to 4
```

## MASK Operator

### Syntax

```
MASK rec-field
```

Where:

*rec-field* is the name of a record field.

### Discussion

The MASK operator defines a value that masks a selected field in a record. This value has 1s in the bit positions specified by *rec-field* and 0s for every other bit position in the record.

### Examples

1. This sequence of instructions creates a record in EAX of the same type as REC's. The EAX FULL field is a copy of the REC.FULL field. All other EAX fields have zeros.

```
MOV EAX, REC  
AND EAX, MASK FULL
```

2. This sequence of instructions creates a record in EAX of the same type as REC's. The FULL field is zeroed. All other EAX fields are copies of the corresponding REC fields.

```
MOV EAX, REC  
AND EAX, NOT MASK FULL
```

## Using Field Names as Shift Counts

### Syntax

*rec-field*

Where:

*rec-field* is the name of a record field.

### Discussion

The record field name specifies the number of bits the record will be shifted. To evaluate a field, the record is shifted right to move the field's contents to the low-order bits of a BYTE, WORD, or DWORD (see the Example).

### Example

This example defines a record. It then isolates and evaluates field C in the record.

```
PATTERN RECORD A:3, B:1, C:2, D:4, E:6
AREC PATTERN <>
:
MOV DX, AREC           ; move record into DX
AND DX, MASK C        ; mask out fields A,B,D,E with
                       ; 0000110000000000B
SHR DX, C              ; DX now equal to value of field C
```

# Instruction Operands

For an assembler instruction to operate on data, the data must be expressed in a form that allows it to be accessed. Some instructions implicitly operate on certain registers. In most cases, data must be specified as an explicit operand. An instruction operand can be expressed as a register, a constant expression, an external constant, a location in memory, or as an expression that combines these components using assembler operators.

## Register Operands

The following registers can be used as explicit operands for many processor instructions:

- 32-bit general registers: EAX, EBX, ECX, EDX, EBP, ESP, ESI, EDI
- 16-bit general registers: AX, BX, CX, DX, SP, BP, SI, DI
- 8-bit general registers: AL, AH, BL, BH, CL, CH, DL, DH
- Segment registers: CS, DS, ES, FS, GS, SS
- Control registers: CR0, CR2, and CR3
- Test registers: TR3, TR4, TR5, TR6, and TR7
- Debug registers: DR0, DR1, DR2, DR3, DR6, and DR7

The segment registers can be used only in `MOV`, `PUSH`, and `POP` instructions. All general registers can be used in processor arithmetic and logical operations.

See also: Processor registers, Appendix A  
processor instructions, Chapter 6

The following examples show instructions that use processor registers as operands:

```
MOV AX, FS           ; contents of FS moved to AX
ADD ESI, EBX        ; ESI := ESI + EBX
MOV AX, BX          ; contents of BX moved to AX
```

The floating-point coprocessor has its own set of registers called the floating-point stack. The floating-point stack consists of eight elements, each of which can be referenced as follows:

```
ST(i)
```

Where:

*i* is a digit from 0 through 7.

The top-of-stack element is always `ST(0)`, which can be abbreviated as `ST`.

See also: Floating-point stack and assembler floating-point instructions, Chapter 7

## Immediate Operands

An immediate operand is an integer or ordinal constant value. An immediate operand is never the destination operand of an assembler instruction. Immediate operands are source operands.

See also: Destination and source operands, Chapter 6

In the following example, 5 is an immediate operand:

```
MOV AL, 5           ; AL := 5
CMP AX, 0FFFFH     ; compare contents of AX to 0FFFFH
```

An immediate may also be a constant expression, such as 15 OR 5 in the following example:

```
CMP AL, 15 OR 5    ; 15 OR 5 is a constant expression
```

OFFSET VAR is an expression that yields an integer, so OFFSET VAR + 1000 is an immediate operand in the following example:

```
MOV EAX, OFFSET VAR + 1000 ; EAX := sum of value of the
                           ; OFFSET of VAR and 1000
```

A segment name represents a logical base address (an ordinal value) so DATASEG is an immediate operand in the following example:

```
MOV AX, DATASEG
MOV DS, AX         ; initializes DS to access DATASEG
```

## Memory Operands

A memory operand refers to a particular location in memory. The general term for a memory operand is an address expression. An address expression may be a simple variable or label name, or it may involve registers, structure fields, and/or constants. Each address expression uses one of the addressing methods described in the next section.

# Memory Addressing Methods

Logical addresses specified in an assembler program must be mapped to processor memory addresses so the program can be executed. The system utilities perform this mapping after the program is assembled. The system utilities translate a program's logical addresses into processor effective addresses. An effective address is an offset from a segment base address.

See also: Processor memory organization and effective addresses, Appendix A

Assembler segment structure and memory addressing methods reflect the processor memory addressing forms. The processor has two forms of addressing:

- **Direct Addressing**  
The effective address (or offset from the segment base) can be:
  - A register
  - The value of a specified variable or label
  - A constant or the value of a constant expression.
- **Indirect Addressing**  
The effective address (offset) is calculated from the contents of a specified base or index register (or a combination of both, with an optional displacement) pointing to a memory location. There are four forms of indirect addressing:
  - Register indirect addressing
  - Based addressing
  - Based indexed addressing
  - Indexed addressing, which may be scaled (32-bit addressing only)

Direct address offsets can be `BYTES`, `WORDS`, `DWORDS` or `PWORDS`. In the special case when individual bits in a string are accessed, the offset indicates the specific bit in a string that is to be affected by the processor bit test instructions.

See also: Bit addressing, in this chapter.

The following sections explain ASM386 direct and indirect addressing forms in more detail.

## Direct Memory Addressing

For direct memory addressing, the instruction operand is specified by a variable or label name. The variable or label refers to a particular location in memory. The contents of the memory location are used as the operand. For example:

```
MOV EAX, COUNT    ; the dword value at memory location
                  ; COUNT is moved into EAX
```

## Indirect Memory Addressing

Figure 5-1 shows how an indirect address offset is calculated for each register addressing form explained after the figure.

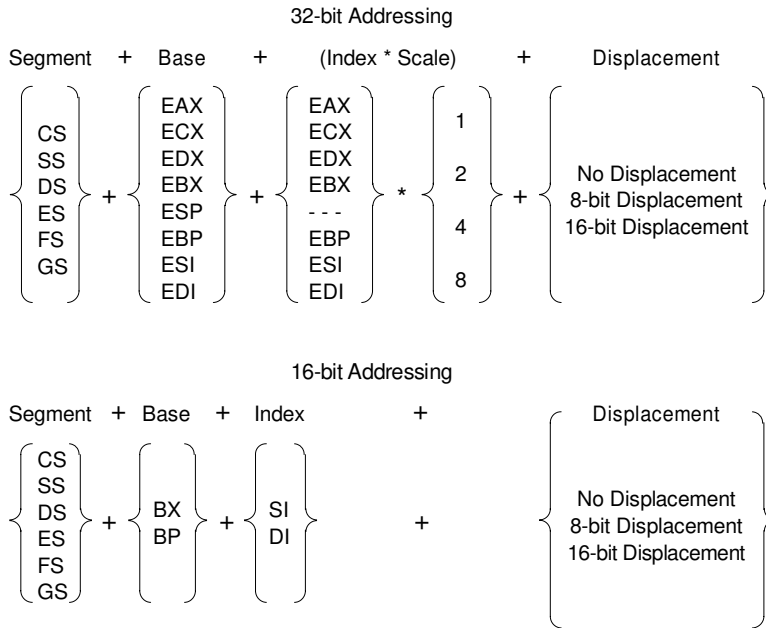

W-3421

**Figure 5-1. Effective Address Calculation**

The segment override operator may be used in some cases to override the processor defaults for segment registers listed in the first column of Figure 5-1, except that segment overrides cannot be specified for the default registers in the following cases:

- ES as the destination of a string operation
- SS for stack operations
- CS for instruction fetches

See also: Appendix A for a summary of the processor default segment selection rules

A register expression uses a base and/or an index register listed in the second and third columns of Figure 5-1. The assembler register addressing forms are:

```
[base-reg] or [index-reg * scale]
[base-reg + index-reg * scale]
[base-reg + disp] or [index-reg * scale + disp]
[base-reg + index-reg * scale + disp]
```

Where:

*base-reg* is any 32-bit general register (EAX, ECX, EDX, EBX, ESP, EBP, ESI, EDI) for 32-bit addressing, and is BX or BP for 16-bit addressing.

*index-reg* is any 32-bit general register except ESP for 32-bit addressing, and is SI or DI for 16-bit addressing.

*scale* is (an optional) constant or constant expression that evaluates to 1-, 2-, 4-, or 8- for 32-bit addressing. It is invalid for 16-bit addressing.

*disp* is an 8- or 32-bit displacement for 32-bit addressing, and is an 8- or 16-bit displacement for 16-bit addressing.

Indirect memory addresses can be formed from different combinations of a base address, an index that may be scaled for 32-bit addressing, and a displacement from the base. Each possible combination is one of the indirect memory addressing forms shown in Figure 5-1.

For all forms, the notation of a set of brackets ([]) enclosing a register name indicates that the register contents point to a memory location that will supply the value to be used as an operand.

The following sections discuss the four forms of indirect addressing and bit addressing.

## Register Indirect Addressing

For register indirect addressing, the offset of the memory location is contained in a base or index register. To address the location:

1. Load the offset into the register, and
2. Use the register name in brackets as the instruction operand.

To indirectly address a variable in a USE16 segment, code something like the following example:

```
MOV BX, OFFSET AVAR ; moves offset of AVAR into BX
MOV AX, [BX]        ; AX now contains contents of AVAR
```

## Based Addressing

The based address form is similar to register indirect form except that a displacement is added to the contents of the register. The displacement can be an 8- or 32-bit number for 32-bit addressing and an 8- or 16-bit number for 16-bit addressing.

In the based address form, the base register contains the offset of a location in memory, called the base. The displacement is used to access another location relative to that base. For example,

```
MOV EBX, OFFSET DATASTRUC ; EBX: = base of DATASTRUC
MOV EBX, [EBX + 4]         ; EBX: = dword located at fourth
                           ; byte from DATASTRUC
```

For 32-bit addressing instructions, any 32-bit general register can be used as the base register. For 16-bit addressing instructions, the BX or BP register can be used as the base register.

## Based Indexed Addressing

Based indexed addressing uses the contents of a base register, the contents of an index register, and an optional displacement. In this addressing form, the base register points to the base of a data structure and the index register is an index into that structure. For example:

```
XOR EAX, EAX           ; clear EAX
MOV EBX, OFFSET ARRAYSTRUC
                        ; load array's base address
MOV ECX, LENGTH ARRAYSTRUC
MOV ESI, 0             ; set index to 0
ALAB:ADD EAX, [EBX + ESI] ; get element
      ADD ESI, 4         ; increment index
      LOOP ALAB         ; repeat sequence
```

For 32-bit addressing, any 32-bit general register can be used as a base register, and any 32-bit general register except ESP can be used as an index register. A scaling factor may multiply the contents of the index register, as explained in the next section.

If no scaling factor is used, the first register specified is assumed to be the base register, and the second register is assumed to be the index register.

For 16-bit addressing, only registers BX and BP can be used as base registers and only SI and DI can be used as index registers; the base and index address may be specified in any order.

## Indexed Addressing

Indexed addressing uses an index register and a displacement. In this case, the contents of the register specify a byte displacement from the offset of the base. For example:

```
MOV SI, 0              ; set indices
MOV DI, 0              ; SI, DI := 0
MOV CX, LENGTH SOURCE; moves count of SOURCE
                        ; data units into CX
ALAB:MOV AX, SOURCE [SI] ; indexed address
      MOV DEST [DI], AX  ; indexed address
      ADD SI, 2          ; point to next word in SOURCE
      ADD DI, 2          ; point to next word in DEST
      LOOP ALAB         ; jump back to ALAB
```

For 32-bit addressing, any 32-bit general register except ESP can be used as an index register. The assembler makes certain assumptions about registers for instructions using 32-bit addressing:

- If there is only one 32-bit register used in an indirect address, it is assumed to be a base register unless it has a scale factor.
- If the 32-bit register is scaled, it is assumed to be an index register even if it is the only 32-bit register in the indirect address.
- If there are two 32-bit registers in an indirect address, the first one (specified on the left) is assumed to be the base and the second is assumed to be the index register, unless one register is scaled.

For 16-bit addressing instructions, only registers SI and DI can be used as index registers.

## Scaling

The scaling factor is used to multiply the value pointed to by the 32-bit index register by 1, 2, 4, or 8. The syntax for specifying a scaled index register is:

```
[register * factor]
```

Where:

*register* is EAX, EBX, ECX, EDX, EBP, EDI, or ESI.

*factor* is a constant expression that evaluates to 1, 2, 4, or 8.

For example:

```
MOV EAX, [EDX*4]
```

uses a scaled indexed address, with the index (EDX) scaled by a factor of 4.

## Default Segment Registers and Anonymous References

Anonymous references such as:

```
[BX]
[EBP]
WORD PTR [DI]
[EBX].FIELDNAME
and BYTE PTR [BP]
```

do not specify a variable name from which a segment can be determined. Note that the structure field name in `[EBX].FIELDNAME` has type and offset attributes, but it has no segment attribute.

Unless you explicitly code a segment override operator before an instruction, segment registers for anonymous references are determined by the processor default segment register selection rules.

DS is the default segment register for all memory references except when BP, EBP, or ESP is used as the base register. When this occurs, SS is the default segment register.

However, you cannot override ES as the destination segment register for string operations. The processor string instructions always use ES as a segment register for operands pointed to by (E)DI, and DS for operands pointed to by (E)SI. Only DS can be overridden with the segment override operator in string operations.

Take care that the correct segment is addressed when an anonymous offset is specified. Unless you code a segment override, the processor default segment will be addressed, and the anonymous offset applied to the default segment.

For example, if a program's variables all reside in segment `SEG1`, as specified by

```
SEG1 SEGMENT RW
    VAR DW 500 DUP(0)      ; 500 words filled with 0's
SEG1 ENDS
```

and if the `ASSUME` directive in the code segment is as follows:

```
ASSUME DS:SEG1
```

then all references to named variables in segment `SEG1` assemble correctly.

If BP is selected as a base register to access elements of `VAR`, as follows:

```
MOV BP, OFFSET VAR
MOV AX, [BP]
```

the SS segment register is accessed at run time instead of DS (no assembly-time error occurs).

To override this default segment register choice, a segment prefix must be used, as follows:

```
MOV BP, OFFSET VAR
MOV AX, DS:[BP]      ; segment override operator
                    ; indicates DS register
```

## Bit Addressing

The BT (bit test), BTS (bit test and set), BTR (bit test and reset), and BTC (bit test and complement) instructions operate on bit strings. These processor instructions make it possible to manipulate individual bits.

A bit string may be stored in a general register or in memory. The following is the general syntax for addressing a bit within a bit string:

*base, offset*

Where:

*base* can be specified using any of the previously mentioned addressing modes described in Memory Addressing Methods.

*offset* must be in the range 0 to 31 for a general register; it can range from -2 to +2 gigabits for a memory address.

The offset specified for a general register addresses a bit within the register. The number specified for offset is taken MOD the size of the base (register). (See the following examples).

All of the bit manipulation instructions load the carry flag with the value of the selected bit. BTS then sets the bit to 1, BTR resets the bit to 0, and BTC complements the bit.

```
BT EAX, 12           ; test bit 12 in register EAX
BTC MEM, 1111B       ; complement bit 15 in word-length
                    ; memory location MEM
BTR AX, 17           ; set bit 1 in AX to 0
BTS BYTE1, 6        ; set bit 6 in byte memory
                    ; location BYTE1 to 1
```

See also: BT, BTS, BTR, and BTC instructions, Chapter 6.



# Processor Instructions 6

---

This chapter has three major sections:

- An overview of the processor instruction set
- A discussion of instruction statements: their syntax, attributes, and encoding format
- An explanation of the notational conventions used in this chapter, followed by a detailed reference for each processor instruction.

See also: Floating-point coprocessor instructions, Chapter 7

## Overview of the Processor Instruction Set

This section groups the processor instructions according to their general functions. It has three major subsections:

- Data Transfer Instructions
- Control Instructions
- Systems Programming Instructions

Some processor instructions are listed more than once in these sections.

See also: *80386 Programmer's Reference Manual* for more information about the following topics:

- Processor application programming
- Processor system programming:
  - System architecture
  - Memory management, protection, multitasking, and input/output
  - Exceptions, interrupts, and debugging
  - Processor initialization, coprocessing, and multiprocessing
  - Processor operating modes, mixing 16-bit and 32-bit code, and porting 286 or 8086 code to the processor

## Data Transfer Instructions

This section classifies the processor instructions according to the following criteria:

- Does the instruction assign values? See Tables 6-1 to 6-4.
- Does the instruction adjust data values? See Tables 6-5 and 6-6.
- Does the instruction make stack transfers? See Table 6-7.
- Does the instruction yield flag values that can be tested by conditional instructions? See Table 6-8.
- Does the instruction test specific flag values to determine its execution or results? See Table 6-9.

Instructions for application programming are listed first in these tables; those for system-only programming, if any, are listed last. Some processor instructions satisfy more than one criterion. These instructions are listed more than once in the following subsections.

### Instructions That Assign Data Values

Most processor instructions assign a value to a location. Tables 6-1 to 6-4 summarize the processor instructions that assign data values:

- Table 6-1 lists processor instructions that make external input/output assignments.
- Table 6-2 lists processor instructions that make internal load and store assignments.
- Table 6-3 lists processor instructions that make uncalculated value assignments.
- Table 6-4 lists processor instructions that make calculated value assignments.

**Table 6-1. External I/O Instructions**

| Processor Instruction | Instruction Description |
|-----------------------|-------------------------|
| IN                    | Input from port         |
| OUT                   | Output to port          |
| INS                   | Input string from port  |
| OUTS                  | Output string to port   |

**Table 6-2. Internal Load and Store Instructions**

| <b>Processor Instruction</b> | <b>Instruction Description</b>                 |
|------------------------------|------------------------------------------------|
| LODS                         | Load string operand                            |
| STOS                         | Store string operand                           |
| LAHF                         | Load flags into AH register                    |
| SAHF                         | Store AH into flags                            |
| LEA                          | Load effective address offset                  |
| LDS                          | Load full pointer into DS: <i>register</i>     |
| LES                          | Load full pointer into ES: <i>register</i>     |
| LFS                          | Load full pointer into FS: <i>register</i>     |
| LGS                          | Load full pointer into GS: <i>register</i>     |
| LSS                          | Load full pointer into SS: <i>register</i>     |
| LSL                          | Load segment limit                             |
| LAR                          | Load access rights (AR) byte                   |
| LGDT                         | Load global descriptor table (GDT) register    |
| LGDTW                        | Load GDTR using 16-bit operand                 |
| LGDTD                        | Load GDTR using 32-bit operand                 |
| SGDT                         | Store GDT register                             |
| SGDTW                        | Store GDTR using 16-bit operand                |
| SGDTD                        | Store GDTR using 32-bit operand                |
| LIDT                         | Load interrupt descriptor table (IDT) register |
| LIDTW                        | Load IDTR using 16-bit operand                 |
| LIDTD                        | Load IDTR using 32-bit operand                 |

continued

**Table 6-2. Internal Load and Store Instructions (continued)**

| <b>Processor Instruction</b> | <b>Instruction Description</b>             |
|------------------------------|--------------------------------------------|
| SIDT                         | Store IDT register                         |
| SIDTW                        | Store IDTR using 16-bit operand            |
| SIDTD                        | Store IDTR using 32-bit operand            |
| LLDT                         | Load local descriptor table (LDT) register |
| SLDT                         | Store LDT register                         |
| LTR                          | Load task register                         |
| STR                          | Store task register                        |
| LMSW                         | Load machine status word (MSW)             |
| SMSW                         | Store MSW                                  |

**Table 6-3. Instructions That Make Uncalculated Value Assignments**

| <b>Processor Instruction</b> | <b>Instruction Description</b>                 |
|------------------------------|------------------------------------------------|
| MOV                          | Move data                                      |
| MOVSX                        | Move sign-extended data                        |
| MOVZX                        | Move zero-extended data                        |
| STC                          | Set carry flag (CF)                            |
| CLC                          | Clear carry flag                               |
| MOVS                         | Move string to string                          |
| STD                          | Set direction flag                             |
| CLD                          | Clear direction flag                           |
| XCHG                         | Exchange register/memory with register         |
| MOV                          | Move to/from control, debug, or test registers |
| STI                          | Set interrupt flag                             |
| CLI                          | Clear interrupt flag                           |
| CLTS                         | Clear TS (task switch) flag in CR0             |

**Table 6-4. Instructions That Make Calculated Value Assignments**

| <b>Processor Instruction</b> | <b>Instruction Description</b>                                     |
|------------------------------|--------------------------------------------------------------------|
| ADD                          | Add                                                                |
| ADC                          | Add with carry                                                     |
| XADD                         | Exchange and add (not available on Intel386 or 376 processors)     |
| SUB                          | Subtract                                                           |
| SBB                          | Subtract with borrow                                               |
| MUL                          | Unsigned multiplication                                            |
| IMUL                         | Signed multiplication                                              |
| DIV                          | Unsigned divide                                                    |
| IDIV                         | Signed divide                                                      |
| INC                          | Increment by 1                                                     |
| DEC                          | Decrement by 1                                                     |
| NEG                          | Two's complement negation                                          |
| NOT                          | One's complement negation (logical NOT)                            |
| AND                          | Logical AND                                                        |
| OR                           | Logical inclusive OR                                               |
| XOR                          | Logical exclusive XOR                                              |
| TEST                         | Logical compare                                                    |
| CMP                          | Compare two operands                                               |
| CMPXCHG                      | Compare and exchange (not available on Intel386 or 376 processors) |
| CMPS                         | Compare two strings                                                |
| SCAS                         | Compare string data                                                |
| CMC                          | Complement carry flag (CF)                                         |
| BT                           | Bit test                                                           |
| BTS                          | Bit test and set                                                   |
| BTR                          | Bit test and reset                                                 |
| BTC                          | Bit test and complement                                            |
| BSF                          | Bit scan forward (LSB to MSB)                                      |
| BSR                          | Bit scan reverse (MSB to LSB)                                      |
| NOP                          | No operation (advances (E)IP)                                      |
| SETcc                        | Set byte on condition                                              |
| LOOPcond                     | Loop control with (E)CX counter (decrements (E)CX)                 |
| Jcc                          | Conditional jumps (add displacement to (E)IP)                      |
| LEA                          | Load effective address                                             |
| VERR                         | Verify segment for reading                                         |
| VERW                         | Verify segment for writing                                         |

## Instructions That Adjust Data

The instructions in Tables 6-5 and 6-6 adjust data values, either by converting data from one type or format to another or by shifting or rotating data values.

**Table 6-5. Data Conversion Instructions**

| <b>Processor Instruction</b> | <b>Instruction Description</b>       |
|------------------------------|--------------------------------------|
| MOVSX                        | Move sign-extended data              |
| MOVZX                        | Move zero-extended data              |
| CBW                          | Convert byte to word                 |
| CWD                          | Convert word to dword                |
| CWDE                         | Convert sign-extended word to dword  |
| CDQ                          | Convert sign-extended dword to qword |
| AAA                          | ASCII adjust AL after addition       |
| AAS                          | ASCII adjust AL after subtraction    |
| DAA                          | Decimal adjust AL after addition     |
| DAS                          | Decimal adjust AL after subtraction  |
| AAM                          | ASCII adjust AX after multiplication |
| AAD                          | ASCII adjust AX before division      |
| ARPL                         | Adjust RPL field of selector         |

**Table 6-6. Shift and Rotate Instructions**

| <b>Processor Instruction</b> | <b>Instruction Description</b>                          |
|------------------------------|---------------------------------------------------------|
| SHL                          | Shift logical left                                      |
| SHR                          | Shift logical right                                     |
| SAL                          | Shift arithmetic left                                   |
| SAR                          | Shift arithmetic right                                  |
| SHLD                         | Shift double precision arithmetic left                  |
| SHRD                         | Shift double precision arithmetic right                 |
| ROL                          | Rotate left                                             |
| ROR                          | Rotate right                                            |
| RCL                          | Rotate through carry flag left                          |
| RCR                          | Rotate through carry flag right                         |
| BSWAP                        | Byte swap (not available on Intel386 or 376 processors) |

## Instructions That Make Stack Transfers

These instructions transfer data values to or from the stack. They also decrement or increment the 32- or 16-bit stack pointer (E) SP. Table 6-7 lists processor instructions that make stack transfers.

See also: Floating-point stack, Chapter 7

**Table 6-7. Stack Transfer Instructions**

| <b>Processor Instruction</b> | <b>Instruction Description</b>                     |
|------------------------------|----------------------------------------------------|
| PUSH                         | Push operand onto stack                            |
| POP                          | Pop dword or word from stack                       |
| PUSHF                        | Push FLAGS register (16-bits) onto stack           |
| PUSHFD                       | Push EFLAGS (32-bits) register onto stack          |
| POPF                         | Pop stack into FLAGS                               |
| POPFD                        | Pop stack into EFLAGS                              |
| PUSHA                        | Push all general word registers onto stack         |
| PUSHAD                       | Push all general dword registers onto stack        |
| POPA                         | Pop stack into word registers (discard SP value)   |
| POPAD                        | Pop stack into dword registers (discard ESP value) |
| ENTER                        | Make stack frame for procedure parameters          |
| LEAVE                        | High level procedure exit                          |

## Instructions That Yield Definitive Flag Values

Processor instructions that assign an either/or flag value also create a value that can be tested for conditional loops, jumps, or other assignments. For the processor comparison and bit test instructions, flag value assignments are the primary execution results. For other processor instructions, either/or flag value assignments are secondary execution results. Table 6-8 lists processor instructions that make either/or assignments to the zero (Z), sign (S), carry (C), auxiliary carry (A), overflow (O), and/or parity (P) flag(s).

See also: Processor flags, Appendix A

**Table 6-8. Processor Instructions That Yield Definitive Flag Values**

| Instruction | Assigns Either/Or Value to Flags |   |   |   |   |   | Instruction Description                                            |
|-------------|----------------------------------|---|---|---|---|---|--------------------------------------------------------------------|
| CMP         | Z                                | S | C | A | O | P | Compare two operands (non-destructive SUB)                         |
| CMPS        | Z                                | S | C | A | O | P | Compare two strings                                                |
| CMPXCHG     | Z                                | S | C | A | O | P | Compare and exchange (not available on Intel386 or 376 processors) |
| SCAS        | Z                                | S | C | A | O | P | Compare string data                                                |
| BT          |                                  |   | C |   |   |   | Bit test                                                           |
| BTS         |                                  |   | C |   |   |   | Bit test and set                                                   |
| BTR         |                                  |   | C |   |   |   | Bit test and reset                                                 |
| BTC         |                                  |   | C |   |   |   | Bit test and complement                                            |
| BSF         | Z                                |   |   |   |   |   | Bit scan forward (LSB to MSB)                                      |
| BSR         | Z                                |   |   |   |   |   | Bit scan reverse (MSB to LSB)                                      |
| ADD         | Z                                | S | C | A | O | P | Add                                                                |
| ADC         | Z                                | S | C | A | O | P | Add with carry                                                     |
| XADD        | Z                                | S | C | A | O | P | Exchange and add (not available on Intel386 or 376 processors)     |
| SUB         | Z                                | S | C | A | O | P | Subtract                                                           |
| SBB         | Z                                | S | C | A | O | P | Subtract with borrow                                               |
| MUL         |                                  |   | C |   | O |   | Multiply                                                           |
| IMUL        |                                  |   | C |   | O |   | Signed multiplication                                              |
| INC         | Z                                | S |   | A | O | P | Increment by 1                                                     |
| DEC         | Z                                | S |   | A | O | P | Decrement by 1                                                     |
| NEG         | Z                                | S | C |   | O | P | Two's complement negation                                          |

continued

**Table 6-8. Processor Instructions That Yield Definitive Flag Values (continued)**

| <b>Instruction</b> | <b>Assigns Either/Or Value to Flags</b> |   |   |   | <b>Instruction Description</b>            |
|--------------------|-----------------------------------------|---|---|---|-------------------------------------------|
| AND                | Z                                       | S |   |   | P Logical AND                             |
| OR                 | Z                                       | S |   |   | P Logical (inclusive) OR                  |
| XOR                | Z                                       | S |   |   | P Logical (exclusive) XOR                 |
| TEST               | Z                                       | S |   |   | P Logical compare (non-destructive AND)   |
| AAA                |                                         |   | C | A | ASCII adjust AL after addition            |
| AAS                |                                         |   | C | A | ASCII adjust AL after subtraction         |
| AAM                | Z                                       | S |   |   | P ASCII adjust AX after multiplication    |
| AAD                | Z                                       | S |   |   | P ASCII adjust AX before division         |
| DAA                | Z                                       | S | C | A | P Decimal adjust AL after addition        |
| DAS                | Z                                       | S | C | A | P Decimal adjust AL after subtraction     |
| ROL                |                                         |   | C |   | Rotate left                               |
| ROR                |                                         |   | C |   | Rotate right                              |
| RCL                |                                         |   | C |   | Rotate through carry flag left            |
| RCR                |                                         |   | C |   | Rotate through carry flag right           |
| SHL                | Z                                       | S | C |   | P Shift logical left                      |
| SAL                | Z                                       | S | C |   | P Shift arithmetic left                   |
| SAR                | Z                                       | S | C |   | P Shift arithmetic right                  |
| SHR                | Z                                       | S | C |   | P Shift logical right                     |
| SHLD               | Z                                       | S | C | O | P Shift double precision arithmetic left  |
| SHRD               | Z                                       | S | C | O | P Shift double precision arithmetic right |
| ARPL               | Z                                       |   |   |   | Adjust RPL field of selector              |
| LAR                | Z                                       |   |   |   | Load AR (access rights) byte              |
| LSL                | Z                                       |   |   |   | Load segment limit                        |
| VERR               | Z                                       |   |   |   | Verify segment for reading                |
| VERW               | Z                                       |   |   |   | Verify segment for writing                |

### Conditional Instructions That Test Flag Values

Three processor instructions depend on flag values for their execution results. The conditional loops and jumps are primarily control transfer instructions; `SETcc` is not.

Table 6-9 lists these instructions and indicates whether each tests the zero (Z), sign (S), carry (C), auxiliary carry (A), overflow (O), and/or parity (P) flag(s).

**Table 6-9. Conditional Instructions That Test Flag Values**

| Instruction | Tests Flag Values | Description                     |
|-------------|-------------------|---------------------------------|
| LOOPcond    | Z                 | Loop control with (E)CX counter |
| SETcc       | Z S C O P         | Set byte on condition           |
| Jcc         | Z S C O P         | Jump if condition is met        |

## Control Instructions

Control instructions either transfer control between code sections or exert control over the processor. Tables 6-10 and 6-11 list these processor instructions.

**Table 6-10. Control Transfer Instructions**

| Processor Instruction | Instruction Description                                |
|-----------------------|--------------------------------------------------------|
| LOOP                  | Loop until count in (E)CX = 0                          |
| LOOPcond              | Loop until count in (E)CX = 0 AND zeroflag = condition |
| JMP                   | Jump to <i>location</i>                                |
| Jcc                   | Jump if flag value(s) = condition                      |
| CALL                  | Call procedure                                         |
| RET                   | Return from procedure                                  |
| INT                   | Call to interrupt procedure                            |
| INTO                  | Call to interrupt procedure on overflow                |
| IRET/IRETD            | Return from interrupt procedure                        |

**Table 6-11. Processor Control Instructions**

| Processor Instruction | Instruction Description                |
|-----------------------|----------------------------------------|
| NOP                   | No operation (uses clocks)             |
| HLT                   | Halt                                   |
| WAIT                  | Wait until BUSY# pin is inactive(high) |

## System Instructions

This section lists processor system instructions. System instructions handle the following general functions:

1. Verification of pointer parameters:

|      |                                                     |
|------|-----------------------------------------------------|
| ARPL | Adjust RPL (requesting privilege level) of selector |
| LAR  | Load AR (access rights) byte                        |
| LSL  | Load segment limit                                  |
| VERR | Verify segment for reading                          |
| VERW | Verify segment for writing                          |

2. Accessing/storing descriptor tables:

|       |                                                |
|-------|------------------------------------------------|
| LGDT  | Load GDT (global descriptor table) register    |
| LGDTW | Load GDT register using 16-bit operand         |
| LGDTD | Load GDT register using 32-bit operand         |
| SGDT  | Store GDT register                             |
| SGDTW | Store GDT register using 16-bit operand        |
| SGDTD | Store GDT register using 32-bit operand        |
| LLDT  | Load LDT (local descriptor table) register     |
| SLDT  | Store LDT register                             |
| LIDT  | Load IDT (interrupt descriptor table) register |
| LIDTW | Load IDT register using 16-bit operand         |
| LIDTD | Load IDT register using 32-bit operand         |
| SIDT  | Store IDT register                             |
| SIDTW | Store IDT register using 16-bit operand        |
| SIDTD | Store IDT register using 32-bit operand        |

3. Input and Output:

|      |                        |
|------|------------------------|
| IN   | Input from port        |
| OUT  | Output to port         |
| INS  | Input string from port |
| OUTS | Output string to port  |

4. Interrupt control:

|       |                                                       |
|-------|-------------------------------------------------------|
| LIDT  | Load IDT (interrupt descriptor table) register        |
| LIDTW | Load IDT register using 16-bit operand                |
| LIDTD | Load IDT register using 32-bit operand                |
| SIDT  | Store IDT register                                    |
| SIDTW | Store IDT register using 16-bit operand               |
| SIDTD | Store IDT register using 32-bit operand               |
| CLI   | Clear IF (interrupt enable) flag in (E)FLAGS register |
| STI   | Set IF flag                                           |

5. Multitasking:

|      |                                    |
|------|------------------------------------|
| LTR  | Load task register                 |
| STR  | Store task register                |
| CLTS | Clear TS (task switch) flag in CR0 |

6. Coprocessing and Multiprocessing:

|      |                                                               |
|------|---------------------------------------------------------------|
| ESC  | Escape instructions (floating-point coprocessor instructions) |
| CLTS | Clear TS (task switch) flag in CR0                            |
| WAIT | Wait until coprocessor is not busy                            |
| LOCK | Assert bus LOCK# signal                                       |

See also: Floating-point coprocessor instructions, Chapter 7

7. Debugging and/or TLB (translation lookaside buffer) testing in a paged memory system:

|     |                                                   |
|-----|---------------------------------------------------|
| MOV | Transfer data to/from debug and/or test registers |
|-----|---------------------------------------------------|

8. System control:

|      |                                         |
|------|-----------------------------------------|
| MOV  | Transfer data to/from control registers |
| LMSW | Load MSW (machine status word) into CR0 |
| SMSW | Store MSW                               |
| HLT  | Halt processor                          |

9. Cache control (not available on Intel386 or 376 processors):

|        |                                      |
|--------|--------------------------------------|
| INVLPG | Invalidate paging cache entry        |
| INVD   | Invalidate data cache                |
| WBINVD | Write back and invalidate data cache |

## Instruction Statements

Instruction statements form the core of an assembler program. These statements define the actual program that the processor (and optional floating-point coprocessor) execute.

## Instruction Statement Syntax

Each assembler instruction has the following syntax:

```
[label:] [prefix]mnemonic[argument[, ...]]
```

Where:

*label* is a unique identifier that defines a label. Labels are optional.

*prefix* is a processor instruction prefix (LOCK or REP). An explicit prefix is optional.

*mnemonic* is a processor or floating-point coprocessor instruction or a programmer-defined codemacro.

*argument* is an operand. Some processor and floating-point coprocessor instructions have no operand. For these instructions, operand(s) are implicit. Other processor instructions require one, two, or three explicit operands. Floating-point coprocessor instructions have, at most, two explicit operands.

See also: Labels, Chapter 4  
processor instructions, in this chapter  
defining codemacros, Chapter 9

For both the processor and the floating-point coprocessor, the general form of an instruction with operands is one of the following:

*mnemonic src*  
where the execution result may be stored either in the source (*src*) itself or in an implicit location.

*mnemonic dest, src*  
where the execution result is stored either in the destination (*dest*) operand or in an implicit location; the instruction's operation does not change the source operand.

The instruction reference pages at the end of this chapter list the valid and/or required operands for each processor instruction (IMUL, SHLD, and SHRD are the only processor instructions that require three operands). The instruction reference pages list the valid and/or required operands for each floating-point instruction.

See also: Instruction reference pages, Chapter 7

## Instruction Attributes

In the context of an assembler program, every instruction has an address size attribute; it may also have an operand size attribute and a stack size attribute. The assembler determines these attributes.

## Address Size Attribute

The assembler can calculate either 32- or 16-bit addresses and offsets.

The assembler determines an instruction's address size attribute as follows:

- If the instruction has an operand, the assembler checks the `USE` attribute of the segment containing the operand:
  - For a `USE32` segment, the instruction's address size attribute is 32-bits.
  - For a `USE16` segment, it is 16-bits.
- If the instruction has no operand and no predefined address size attribute, the assembler checks the `USE` attribute of the current code segment to determine the address size attribute.
- If the instruction contains an anonymous reference the assembler checks the size of the register used in the reference. For example,

```
PUSH DWORD PTR [EAX]
```

implies the `USE32` attribute. Because `EAX` is a 32-bit register, this `PUSH` instruction's address size attribute is 32-bits.

See also: `USE16` and `USE32` segments, Chapter 2

## Operand Size Attribute

When determining the operand size attribute for most instructions, the assembler considers the type of the instruction operand(s), or, for no-operand instructions, the type of the operand implied by the instruction's mnemonic. An instruction that accesses dwords (32-bits) or words (16-bits) has an operand size attribute of 32- or 16-bits, respectively. An instruction that accesses a byte has the operand size attribute of the current code segment.

The assembler will flag an inconsistency in the use of operands as an error. For example,

```
ADD EAX, WORD_VAR
```

will be flagged as an error because `EAX` (32-bit register operand) cannot be used with `WORD_VAR` (16-bits).

## Stack Size Attribute

Instructions that use the stack have a stack size attribute of 32- or 16-bits. The assembler determines an instruction's stack size attribute according to the `USE` attribute of the stack segment. The stack segment `USE` attribute is either:

- The current default for the module containing the instruction
- Or, the `USE` attribute of the stack segment definition

Instructions with a stack size attribute of 32 use the 32-bit ESP register as the stack pointer; those with a stack size attribute of 16 use the 16-bit SP register as the stack pointer.

## Instruction Encoding Format

All instruction encodings are subsets of the general instruction opcode format shown in Figure 6-1.

| Instruction Prefix       | Address-size Prefix | Operand-size Prefix | Segment Override |
|--------------------------|---------------------|---------------------|------------------|
| 0 or 1                   | 0 or 1              | 0 or 1              | 0 or 1           |
| -----<br>Number of Bytes |                     |                     |                  |

| Opcode                   | ModRM  | SIB    | Displacement | Immediate    |
|--------------------------|--------|--------|--------------|--------------|
| 1 or 2                   | 0 or 1 | 0 or 1 | 0, 1, 2 or 4 | 0, 1, 2 or 4 |
| -----<br>Number of Bytes |        |        |              |              |

W-3422

**Figure 6-1. Instruction Encoding Format**

Instruction encodings consist of:

- Optional instruction prefixes
- One or two primary opcode bytes
- Possibly an address specifier consisting of:
  - The `ModRM` byte and the `SIB` (Scale Index Base) byte
  - A displacement, if required
  - An immediate data field, if required

Encoding fields vary depending on the class of operation. Smaller encoding fields can be defined within the primary opcode(s). These fields define the direction of the operation, the size of the displacements, the register encoding, or the sign extension.

Most instructions that refer to an operand in memory have an addressing form byte following the primary opcode byte(s). (The exceptions are the `IRET/IRETD`, `INT/INTO`, and all `PUSH` and `POP` instructions.) This byte, called the `ModRM` byte, specifies the address form to be used. Certain encodings of the `ModRM` byte indicate a second addressing byte, the `SIB` (Scale Index Base) byte; this follows the `ModRM` byte and is required to fully specify the addressing form (see Figure 6-2).

Addressing forms can include a displacement immediately following either the `ModRM` or `SIB` byte. If a displacement is present, it can be 8-, 16-, or 32-bits.

If the instruction specifies an immediate operand, the immediate operand follows any displacement bytes; it is always the last field of the instruction.

## Instruction Prefix Codes

Instruction prefix codes occur in three cases:

1. A programmer-specified `REP` or `LOCK` prefix precedes the instruction. The assembler generates one of the following prefixes:

|     |                                                                     |
|-----|---------------------------------------------------------------------|
| F3H | <code>REP</code> prefix (used only with string instructions)        |
| F3H | <code>REPE/REPZ</code> prefix (used only with string instructions)  |
| F2H | <code>REPNE/REPZ</code> prefix (used only with string instructions) |
| F0H | <code>LOCK</code> prefix                                            |

2. A segment override is specified for the instruction. The assembler automatically generates one of the following prefixes:

|     |                                         |
|-----|-----------------------------------------|
| 2EH | <code>CS</code> segment override prefix |
| 36H | <code>SS</code> segment override prefix |
| 3EH | <code>DS</code> segment override prefix |
| 26H | <code>ES</code> segment override prefix |
| 64H | <code>FS</code> segment override prefix |
| 65H | <code>GS</code> segment override prefix |

3. An instruction's address and/or operand size requires, at most, a 2-byte prefix. The assembler automatically generates one or more of the following prefixes:

67H            Address size prefix  
 66H            Operand size prefix

See also:    LOCK and REP for more information about specifying prefixes with instructions, in this chapter

Table 6-12 shows when the assembler generates address and operand size prefixes for an instruction according to the relationships among its USE, address size, and operand size attributes.

**Table 6-12. Generation of Address and Operand Size Prefixes**

| Prefixes Generated by Assembler |             | Attributes   |              |                             |
|---------------------------------|-------------|--------------|--------------|-----------------------------|
| Address 67H                     | Operand 66H | Address Size | Operand Size | USE of Current Code Segment |
| no                              | no          | 16           | 16           | USE16                       |
| no                              | yes         | 16           | 32           | USE16                       |
| yes                             | no          | 32           | 16           | USE16                       |
| yes                             | yes         | 32           | 32           | USE16                       |
| no                              | no          | 32           | 32           | USE32                       |
| no                              | yes         | 32           | 16           | USE32                       |
| yes                             | no          | 16           | 32           | USE32                       |
| yes                             | yes         | 16           | 16           | USE32                       |

## ModRM and SIB Bytes

The `ModRM` and `SIB` bytes follow the opcode byte(s) in many of the processor instructions. They contain the following information:

- Indexing type or register number to be used in the instruction
- Register to be used, or more information to select the instruction
- Base, index, and scale information

Figure 6-2 shows the formats of the `ModRM` and `SIB` bytes.

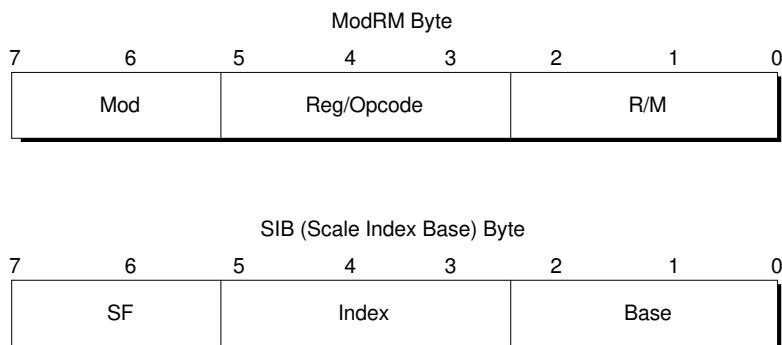

W-3423

**Figure 6-2. ModRM and SIB Byte Formats**

The `ModRM` byte contains three fields of information:

- `mod` occupies the 2 most significant bits. The `mod` field combines with the `r/m` field to form 32 possible values representing 8 general registers and 24 indexing modes.
- `reg` occupies the next 3-bits following the `mod` field. The `reg` field specifies either a register number or three more bits of opcode information. The meaning of the `reg` field is determined by the first (opcode) byte of the instruction.
- `r/m` occupies the 3 least significant bits. The `r/m` field can specify a register as the location of an operand, or it can be combined with the `mod` field to form the addressing-mode encoding.
- See also: `MOV Special Registers` instruction for the control, test, and debug register `reg` values, in this chapter

32-bit based-indexed and scaled-indexed addressing forms also require the `SIB` byte. The presence of the `SIB` byte is indicated by certain encodings of `ModRM` bytes. The `SIB` byte then includes the following fields:

- `sf` occupies the 2 most significant bits. It specifies the scale factor.
- `index` occupies the next 3-bits. It specifies the register number of the index register.
- `base` occupies the 3 least significant bits. It specifies the register number of the base register.

The following tables illustrate the addressing forms for 16- and 32-bit `ModRM` bytes and for 32-bit `SIB` bytes:

Table 6-13 shows the 16-bit addressing forms specified by the `ModRM` byte.

Table 6-14 shows the 32-bit addressing forms specified by the `ModRM` byte.

Table 6-15 shows the 32-bit addressing forms specified by the `SIB` byte.

**Table 6-13. 16-Bit Addressing Forms with ModRM Byte in Hexadecimal**

| r8(/r)            | AL         | CL  | DL                          | BL  | AH  | CH  | DH  | BH  |    |    |
|-------------------|------------|-----|-----------------------------|-----|-----|-----|-----|-----|----|----|
| r16(/r)           | AX         | CX  | DX                          | BX  | SP  | BP  | SI  | DI  |    |    |
| r32(/r)           | EAX        | ECX | EDX                         | EBX | ESP | EBP | ESI | EDI |    |    |
| /digit(Opcode)    | 0          | 1   | 2                           | 3   | 4   | 5   | 6   | 7   |    |    |
| REG =             | 000        | 001 | 010                         | 011 | 100 | 101 | 110 | 111 |    |    |
| Effective Address | ModRM Bits |     | ModRM Values in Hexadecimal |     |     |     |     |     |    |    |
|                   | MOD        | R/M |                             |     |     |     |     |     |    |    |
| [BX + SI]         | 00         | 000 | 00                          | 08  | 10  | 18  | 20  | 28  | 30 | 38 |
| [BX + DI]         |            | 001 | 01                          | 09  | 11  | 19  | 21  | 29  | 31 | 39 |
| [BP + SI]         |            | 010 | 02                          | 0A  | 12  | 1A  | 22  | 2A  | 32 | 3A |
| [BP + DI]         |            | 011 | 03                          | 0B  | 13  | 1B  | 23  | 2B  | 33 | 3B |
| [SI]              |            | 100 | 04                          | 0C  | 14  | 1C  | 24  | 2C  | 34 | 3C |
| [DI]              |            | 101 | 05                          | 0D  | 15  | 1D  | 25  | 2D  | 35 | 3D |
| disp16            |            | 110 | 06                          | 0E  | 16  | 1E  | 26  | 2E  | 36 | 3E |
| [BX]              | 111        | 07  | 0F                          | 17  | 1F  | 27  | 2F  | 37  | 3F |    |
| [BX + SI]+disp8   | 01         | 000 | 40                          | 48  | 50  | 58  | 60  | 68  | 70 | 78 |
| [BX + DI]+disp8   |            | 001 | 41                          | 49  | 51  | 59  | 61  | 69  | 71 | 79 |
| [BP + SI]+disp8   |            | 010 | 42                          | 4A  | 52  | 5A  | 62  | 6A  | 72 | 7A |
| [BP + DI]+disp8   |            | 011 | 43                          | 4B  | 53  | 5B  | 63  | 6B  | 73 | 7B |
| [SI]+disp8        |            | 100 | 44                          | 4C  | 54  | 5C  | 64  | 6C  | 74 | 7C |
| [DI]+disp8        |            | 101 | 45                          | 4D  | 55  | 5D  | 65  | 6D  | 75 | 7D |
| [BP]+disp8        |            | 110 | 46                          | 4E  | 56  | 5E  | 66  | 6E  | 76 | 7E |
| [BX]+disp8        | 111        | 47  | 4F                          | 57  | 5F  | 67  | 6F  | 77  | 7F |    |
| [BX + SI]+disp16  | 10         | 000 | 80                          | 88  | 90  | 98  | A0  | A8  | B0 | B8 |
| [BX + DI]+disp16  |            | 001 | 81                          | 89  | 91  | 99  | A1  | A9  | B1 | B9 |
| [BP + SI]+disp16  |            | 010 | 82                          | 8A  | 92  | 9A  | A2  | AA  | B2 | BA |
| [BP + DI]+disp16  |            | 011 | 83                          | 8B  | 93  | 9B  | A3  | AB  | B3 | BB |
| [SI]+disp16       |            | 100 | 84                          | 8C  | 94  | 9C  | A4  | AC  | B4 | BC |
| [DI]+disp16       |            | 101 | 85                          | 8D  | 95  | 9D  | A5  | AD  | B5 | BD |
| [BP]+disp16       |            | 110 | 86                          | 8E  | 96  | 9E  | A6  | AE  | B6 | BE |
| [BX]+disp16       | 111        | 87  | 8F                          | 97  | 9F  | A7  | AF  | B7  | BF |    |
| EAX/AX/AL         | 11         | 000 | C0                          | C8  | D0  | D8  | E0  | E8  | F0 | F8 |
| ECX/CX/CL         |            | 001 | C1                          | C9  | D1  | D9  | E1  | E9  | F1 | F9 |
| EDX/DX/DL         |            | 010 | C2                          | CA  | D2  | DA  | E2  | EA  | F2 | FA |
| EBX/BX/BL         |            | 011 | C3                          | CB  | D3  | DB  | E3  | EB  | F3 | FB |
| ESP/SP/AH         |            | 100 | C4                          | CC  | D4  | DC  | E4  | EC  | F4 | FC |
| EBP/BP/CH         |            | 101 | C5                          | CD  | D5  | DD  | E5  | ED  | F5 | FD |
| ESI/SI/DH         |            | 110 | C6                          | CE  | D6  | DE  | E6  | EE  | F6 | FE |
| EDI/DI/BH         | 111        | C7  | CF                          | D7  | DF  | E7  | EF  | F7  | FF |    |

**disp8** denotes an 8-bit displacement following the ModRM byte that is sign-extended bits and added to the index. **disp16** denotes a 16-bit displacement following the ModRM byte that is added to the index. The default segment register is SS for effective addresses containing a BP index; it is DS for other effective addresses.

**Table 6-14. 32-Bit Addressing Forms with ModRM Byte in Hexadecimal**

| r8(/r)            |            | AL  | CL                          | DL  | BL  | AH  | CH  | DH  | BH  |    |
|-------------------|------------|-----|-----------------------------|-----|-----|-----|-----|-----|-----|----|
| r16(/r)           |            | AX  | CX                          | DX  | BX  | SP  | BP  | SI  | DI  |    |
| r32(/r)           |            | EAX | ECX                         | EDX | EBX | ESP | EBP | ESI | EDI |    |
| /digit(Opcode)    |            | 0   | 1                           | 2   | 3   | 4   | 5   | 6   | 7   |    |
| REG =             |            | 000 | 001                         | 010 | 011 | 100 | 101 | 110 | 111 |    |
| Effective Address | ModRM Bits |     | ModRM Values in Hexadecimal |     |     |     |     |     |     |    |
|                   | MOD        | R/M |                             |     |     |     |     |     |     |    |
| [EAX]             |            | 000 | 00                          | 08  | 10  | 18  | 20  | 28  | 30  | 38 |
| [ECX]             |            | 001 | 01                          | 09  | 11  | 19  | 21  | 29  | 31  | 39 |
| [EDX]             |            | 010 | 02                          | 0A  | 12  | 1A  | 22  | 2A  | 32  | 3A |
| [EBX]             |            | 011 | 03                          | 0B  | 13  | 1B  | 23  | 2B  | 33  | 3B |
| [--][--]          | 00         | 100 | 04                          | 0C  | 14  | 1C  | 24  | 2C  | 34  | 3C |
| disp32            |            | 101 | 05                          | 0D  | 15  | 1D  | 25  | 2D  | 35  | 3D |
| [ESI]             |            | 110 | 06                          | 0E  | 16  | 1E  | 26  | 2E  | 36  | 3E |
| [EDI]             |            | 111 | 07                          | 0F  | 17  | 1F  | 27  | 2F  | 37  | 3F |
| disp8[EAX]        |            | 000 | 40                          | 48  | 50  | 58  | 60  | 68  | 70  | 78 |
| disp8[ECX]        |            | 001 | 41                          | 49  | 51  | 59  | 61  | 69  | 71  | 79 |
| disp8[EDX]        |            | 010 | 42                          | 4A  | 52  | 5A  | 62  | 6A  | 72  | 7A |
| disp8[EBX]        |            | 011 | 43                          | 4B  | 53  | 5B  | 63  | 6B  | 73  | 7B |
| disp8[--][--]     | 01         | 100 | 44                          | 4C  | 54  | 5C  | 64  | 6C  | 74  | 7C |
| disp8[EBP]        |            | 101 | 45                          | 4D  | 55  | 5D  | 65  | 6D  | 75  | 7D |
| disp8[ESI]        |            | 110 | 46                          | 4E  | 56  | 5E  | 66  | 6E  | 76  | 7E |
| disp8[EDI]        |            | 111 | 47                          | 4F  | 57  | 5F  | 67  | 6F  | 77  | 7F |
| disp32[EAX]       |            | 000 | 80                          | 88  | 90  | 98  | A0  | A8  | B0  | B8 |
| disp32[ECX]       |            | 001 | 81                          | 89  | 91  | 99  | A1  | A9  | B1  | B9 |
| disp32[EDX]       |            | 010 | 82                          | 8A  | 92  | 9A  | A2  | AA  | B2  | BA |
| disp32[EBX]       |            | 011 | 83                          | 8B  | 93  | 9B  | A3  | AB  | B3  | BB |
| disp32[--][--]    | 10         | 100 | 84                          | 8C  | 94  | 9C  | A4  | AC  | B4  | BC |
| disp32[EBP]       |            | 101 | 85                          | 8D  | 95  | 9D  | A5  | AD  | B5  | BD |
| disp32[ESI]       |            | 110 | 86                          | 8E  | 96  | 9E  | A6  | AE  | B6  | BE |
| disp32[EDI]       |            | 111 | 87                          | 8F  | 97  | 9F  | A7  | AF  | B7  | BF |
| EAX/AX/AL         |            | 000 | C0                          | C8  | D0  | D8  | E0  | E8  | F0  | F8 |
| ECX/CX/CL         |            | 001 | C1                          | C9  | D1  | D9  | E1  | E9  | F1  | F9 |
| EDX/DX/DL         |            | 010 | C2                          | CA  | D2  | DA  | E2  | EA  | F2  | FA |
| EBX/BX/BL         | 11         | 011 | C3                          | CB  | D3  | DB  | E3  | EB  | F3  | FB |
| ESP/SP/AH         |            | 100 | C4                          | CC  | D4  | DC  | E4  | EC  | F4  | FC |
| EBP/BP/CH         |            | 101 | C5                          | CD  | D5  | DD  | E5  | ED  | F5  | FD |
| ESI/SI/DH         |            | 110 | C6                          | CE  | D6  | DE  | E6  | EE  | F6  | FE |
| EDI/DI/BH         |            | 111 | C7                          | CF  | D7  | DF  | E7  | EF  | F7  | FF |

[--][--] means a SIB byte follows the ModRM byte. **disp8** denotes an 8-bit displacement following the SIB byte that is sign-extended to 32 bits and added to the index. **disp32** denotes a 32-bit displacement following the ModRM byte that is added to the index.

**Table 6-15. 32-Bit Addressing Forms with SIB Byte in Hexadecimal**

| r32          |    |       | EAX                       | ECX | EDX | EBX | ESP | [*] | ESI | EDI |
|--------------|----|-------|---------------------------|-----|-----|-----|-----|-----|-----|-----|
| Base =       |    |       | 0                         | 1   | 2   | 3   | 4   | 5   | 6   | 7   |
| Base =       |    |       | 000                       | 001 | 010 | 011 | 100 | 101 | 110 | 111 |
| Scaled Index | SF | Index | SIB Values in Hexadecimal |     |     |     |     |     |     |     |
| [EAX]        |    | 000   | 00                        | 01  | 02  | 03  | 04  | 05  | 06  | 07  |
| [ECX]        |    | 001   | 08                        | 09  | 0A  | 0B  | 0C  | 0D  | 0E  | 0F  |
| [EDX]        |    | 010   | 10                        | 11  | 12  | 13  | 14  | 15  | 16  | 17  |
| [EBX]        | 00 | 011   | 18                        | 19  | 1A  | 1B  | 1C  | 1D  | 1E  | 1F  |
| none         |    | 100   | 20                        | 21  | 22  | 23  | 24  | 25  | 26  | 27  |
| [EBP]        |    | 101   | 28                        | 29  | 2A  | 2B  | 2C  | 2D  | 2E  | 2F  |
| [ESI]        |    | 110   | 30                        | 31  | 32  | 33  | 34  | 35  | 36  | 37  |
| [EDI]        |    | 111   | 38                        | 39  | 3A  | 3B  | 3C  | 3D  | 3E  | 3F  |
| [EAX*2]      |    | 000   | 40                        | 41  | 42  | 43  | 44  | 45  | 46  | 47  |
| [ECX*2]      |    | 001   | 48                        | 49  | 4A  | 4B  | 4C  | 4D  | 4E  | 4F  |
| [EDX*2]      |    | 010   | 50                        | 51  | 52  | 53  | 54  | 55  | 56  | 57  |
| [EBX*2]      | 01 | 011   | 58                        | 59  | 5A  | 5B  | 5C  | 5D  | 5E  | 5F  |
| none         |    | 100   | 60                        | 61  | 62  | 63  | 64  | 65  | 66  | 67  |
| [EBP*2]      |    | 101   | 68                        | 69  | 6A  | 6B  | 6C  | 6D  | 6E  | 6F  |
| [ESI*2]      |    | 110   | 70                        | 71  | 72  | 73  | 74  | 75  | 76  | 77  |
| [EDI*2]      |    | 111   | 78                        | 79  | 7A  | 7B  | 7C  | 7D  | 7E  | 7F  |
| [EAX*4]      |    | 000   | 80                        | 81  | 82  | 83  | 84  | 85  | 86  | 87  |
| [ECX*4]      |    | 001   | 88                        | 89  | 8A  | 8B  | 8C  | 8D  | 8E  | 8F  |
| [EDX*4]      |    | 010   | 90                        | 91  | 92  | 93  | 94  | 95  | 96  | 97  |
| [EBX*4]      | 10 | 011   | 98                        | 99  | 9A  | 9B  | 9C  | 9D  | 9E  | 9F  |
| none         |    | 100   | A0                        | A1  | A2  | A3  | A4  | A5  | A6  | A7  |
| [EBP*4]      |    | 101   | A8                        | A9  | AA  | AB  | AC  | AD  | AE  | AF  |
| [ESI*4]      |    | 110   | B0                        | B1  | B2  | B3  | B4  | B5  | B6  | B7  |
| [EDI*4]      |    | 111   | B8                        | B9  | BA  | BB  | BC  | BD  | BE  | BF  |
| [EAX*8]      |    | 000   | C0                        | C1  | C2  | C3  | C4  | C5  | C6  | C7  |
| [ECX*8]      |    | 001   | C8                        | C9  | CA  | CB  | CC  | CD  | CE  | CF  |
| [EDX*8]      |    | 010   | D0                        | D1  | D2  | D3  | D4  | D5  | D6  | D7  |
| [EBX*8]      | 11 | 011   | D8                        | D9  | DA  | DB  | DC  | DD  | DE  | DF  |
| none         |    | 100   | E0                        | E1  | E2  | E3  | E4  | E5  | E6  | E7  |
| [EBP*8]      |    | 101   | E8                        | E9  | EA  | EB  | EC  | ED  | EE  | EF  |
| [ESI*8]      |    | 110   | F0                        | F1  | F2  | F3  | F4  | F5  | F6  | F7  |
| [EDI*8]      |    | 111   | F8                        | F9  | FA  | FB  | FC  | FD  | FE  | FF  |

The [\*] heading in column 5 of the SIB values means a disp32 with no base if MOD is 00, EBP otherwise. Depending on the value of MOD, the following addressing modes are possible: disp32[index], disp8[EBP] [index], and disp32[EBP] [index] with MOD values 00, 01, and 10, respectively.

# Processor Instruction Set Reference

This section first explains how to use the instruction set reference pages and how to find instructions that are grouped with others. The reference pages for each processor instruction are at the end of this section.

## How to Read the Instruction Set Reference Pages

For each processor instruction, a table summarizes the opcode, instruction syntax, clocks, and description of its operation. Following the instruction table are reference page sections titled Operation, Discussion, Flags Affected, and Exceptions by Mode. The following is an example of an instruction table:

| Opcode          | Instruction                    | Clocks | Description                            |
|-----------------|--------------------------------|--------|----------------------------------------|
| 0C <i>ib</i>    | OR AL, <i>imm8</i>             | 2      | OR immediate byte to AL                |
| 0D <i>iw</i>    | OR AX, <i>imm16</i>            | 2      | OR immediate word to AX                |
| 0D <i>id</i>    | OR EAX, <i>imm32</i>           | 2      | OR immediate dword to EAX              |
| 80 /1 <i>ib</i> | OR <i>r/m8</i> , <i>imm8</i>   | 2/7    | OR immediate byte to <i>r/m</i> byte   |
| 81 /1 <i>iw</i> | OR <i>r/m16</i> , <i>imm16</i> | 2/7    | OR immediate word to <i>r/m</i> word   |
| 81 /1 <i>id</i> | OR <i>r/m32</i> , <i>imm32</i> | 2/7    | OR immediate dword to <i>r/m</i> dword |
| 08 / <i>r</i>   | OR <i>r/m8</i> , <i>r8</i>     | 2/6    | OR byte register to <i>r/m</i> byte    |
| 09 / <i>r</i>   | OR <i>r/m16</i> , <i>r16</i>   | 2/6    | OR word register to <i>r/m</i> word    |
| 09 / <i>r</i>   | OR <i>r/m32</i> , <i>r32</i>   | 2/6    | OR dword register to <i>r/m</i> dword  |
| 0A / <i>r</i>   | OR <i>r8</i> , <i>r/m8</i>     | 2/7    | OR <i>r/m</i> byte to byte register    |
| 0B / <i>r</i>   | OR <i>r16</i> , <i>r/m16</i>   | 2/7    | OR <i>r/m</i> word to word register    |
| 0B / <i>r</i>   | OR <i>r32</i> , <i>r/m32</i>   | 2/7    | OR <i>r/m</i> dword to dword register  |

The following subsections explain the notational conventions and abbreviations used in the instruction table columns and in the reference page sections.

## Opcode Column

The opcode column gives the complete object code produced for each form of the instruction. When possible, codes are expressed as hexadecimal bytes in the same order in which they appear in memory. Definitions of entries other than hexadecimal bytes are as follows:

*/digit* is a digit from 0 to 7; it indicates that the ModRM byte of the instruction uses only the *r/m* (register or memory) operand. The reg field of the ModRM byte contains the digit (0..7) that provides an extension to the instruction's opcode.

*/r* indicates that the ModRM byte of the instruction contains both a register operand and an *r/m* operand.

*cb, cw, cd, cp* is a 1-byte (*cb*), 2-byte (*cw*), 4-byte (*cd*), or 6-byte (*cp*) value following the opcode that is used to specify a code offset and possibly a new value for the code segment register.

*ib, iw, id* is a 1-byte (*ib*), 2-byte (*iw*), or 4-byte (*id*) immediate operand to the instruction that follows the opcode, ModRM, and SIB bytes. The opcode determines if the operand is a signed value. All words (*iw*) and dwords (*id*) are given with the low-order byte first.

*+rb, +rw, +rd* is a register code from 0 to 7 that is added to the hexadecimal byte at the left of the plus sign to form a single opcode byte. The register codes are:

| <i>rb</i> | <i>rw</i> | <i>rd</i> |
|-----------|-----------|-----------|
| AL=0      | AX=0      | EAX=0     |
| CL=1      | CX=1      | ECX=1     |
| DL=2      | DX=2      | EDX=2     |
| BL=3      | BX=3      | EBX=3     |
| AH=4      | SP=4      | ESP=4     |
| CH=5      | BP=5      | EBP=5     |
| DH=6      | SI=6      | ESI=6     |
| BH=7      | DI=7      | EDI=7     |

## Instruction Column

The instruction column gives the syntax of the instruction statement as it would appear in an assembler program.

The following is a list of the symbols used to represent operands in the instruction statements:

*r8* is one of the byte registers AL, CL, DL, BL, AH, DH, CH, or BH. For example, `MOV r8, imm8` can be coded

```
MOV DH, 3
```

*r16* is one of the word registers AX, CX, DX, BX, SP, BP, SI, or DI. For example, `INC r16` can be coded

```
INC BX
```

*r32* is one of the dword registers EAX, EBX, ECX, EDX, ESP, EBP, ESI, or EDI. For example, `DEC r32` can be coded

```
DEC EDX
```

*r/m8* is a 1-byte operand that is either the contents of a byte register (AL, BL, CL, DL, AH, BH, CH, DH), or a byte from memory. For example, `MOV r8,r/m8` could be coded

```
MOV DL, AH
```

meaning set DL to the value in AH. It could also be coded

```
MOV DL, POWER_FLAG
```

meaning set DL to the memory byte variable `POWER_FLAG`, where `POWER_FLAG` was declared at the top of the program.

*r/m16* is a word register or memory operand used for instructions whose operand size attribute is 16-bits. The word registers are AX, BX, CX, DX, SP, BP, SI, DI. The contents of memory are found at the address provided by the effective address computation. As an example, `ADD r/m16, imm8` could be coded

```
ADD SP, 10
```

meaning add 10 to the contents of the SP register. It could also be coded

```
ADD [BP].WORD_ELEM, 10
```

meaning add 10 to the memory word `WORD_ELEM`, which is part of a structure addressed by the BP register.

*r/m32* is a dword register or memory operand used for instructions whose operand size attribute is 32-bits. The dword registers are EAX, EBX, ECX, EDX, ESP, EBP, ESI, EDI. The contents of memory are found at the address provided by the effective address computation.

*m8* is a memory byte that can apply to all addressing forms. *m8* can be a simple memory variable of type `BYTE`, or it can be indexed. For example, `LODS m8` can be coded

```
LODS BSTRING
```

where `BSTRING` is a byte array addressed by the (E)SI register.

*m16* is a memory word that can apply to all addressing forms. *m16* can be a simple variable of type `WORD`, or it can be indexed. For example, `MOV DS, m16` can be coded

```
MOV DS, DATA_SELECTOR
```

where `DATA_SELECTOR` is a memory variable declared with the following statement

```
DATA_SELECTOR DW DATA
```

```
MOV DS, m16 can also be coded
```

```
MOV DS, SELECTOR_ARRAY [DI]
```

where `DI` is a run-time index into the fixed word array `SELECTOR_ARRAY`.

*m32* is a memory dword that can apply to all addressing forms.

*m* is a memory operand whose type is not checked by the assembler.

See also: `BTS` and other bit instructions for an explanation of *m* usage, in this chapter

*imm8* is an immediate byte value. *imm8* is a signed number in the range `-128..127`, a symbol equated to such a number, or an expression evaluating to such a number. For example, `ADD AL, imm8` can be coded

```
ADD AL, 37
```

meaning add the number 37 to the AL register. `IN AX, imm8` can be coded

```
IN AX, SERIAL_PORT
```

if the following statement appears elsewhere within the program

```
SERIAL_PORT EQU 40H  
  
MOV r8, imm8 can be coded  
  
MOV DL, LENGTH PTR_TABLE + 1
```

if the following statement appears elsewhere within the program

```
PTR_TABLE DW 30 DUP (?)
```

`MOV DL, LENGTH PTR_TABLE + 1` loads 31 into the DL register. Negative values between -128 and -255 wrap around to positive numbers because the largest negative number that can be represented with 8-bits is -128. Numbers between 127 and 255 can be used for the representation of unsigned numbers. When instructions combine an *imm8* with a word or dword operand, the immediate value is sign-extended to form a word or dword.

*imm16* is an immediate word value used for instructions whose operand size attribute is 16-bits. This is a number in the range -32768..32767, a symbol equated to such a number, or an expression evaluating to such a number. For example, `ADD AX, imm16` can be coded

```
ADD AX, 1000
```

meaning add the number 1000 to the AX register. `MOV r16, imm16` can be coded

```
MOV DI, OFFSET COUNTER
```

where `COUNTER` is a label. The instruction would move `COUNTER`'s offset within its segment (not the contents of `COUNTER`) into the DI register.

*imm32* is an immediate dword value used for instructions whose operand size attribute is 32-bits. This is a number in the range -2147483648..2147483647.

*rel8* is a label in the range from 128 bytes before the end of the instruction to 127 bytes after the end of the instruction. For example, `JMP rel8` can be coded

```
JMP PROCESS_NEXT
```

if the label `PROCESS_NEXT`: appears nearby in the same code segment. `LOOP rel8` can be coded

```
FLOOP XY_LOOP
```

if `XY_LOOP`: appears several lines above.

*rel16, rel32*

is a label within the same code segment as the instruction. *rel16* applies to instructions with an operand size attribute of 16-bits; *rel32* applies to instructions with an operand size attribute of 32-bits. The label cannot be a FAR label. For example, `JMP rel16` can be coded

```
JMP ABORTX
```

if the destination label is declared (possibly several pages away) in the same code segment as the jump. `CALL rel16` can be coded

```
CALL GET_CONSOLE
```

if the following statement appears elsewhere in the program

```
EXTRN GET_CONSOLE:NEAR
```

*ptr16:16, ptr16:32*

is a FAR label, typically in a code segment different from that of the instruction. These labels are also called full pointers. *ptr16:16* is used when the instruction's operand size attribute is 16-bits; *ptr16:32* is used with the 32-bit attribute. The notation `16:16` indicates that the value of the pointer has two parts. The value on the left of the colon is a 16-bit selector or value destined for the code segment register. The value on the right corresponds to the offset within the destination segment. For example, `CALL ptr16:16` can be coded

```
CALL SERVICE_ACTION
```

if the following statement appears elsewhere in the program

```
EXTRN SERVICE_ACTION:FAR
```

*m16:16, m16:32*

is a memory operand containing a full pointer composed of two numbers. The number to the left of the colon corresponds to the pointer's segment selector. The number to the right corresponds to its offset. Like the *ptr16:16* and *ptr16:32* operands, *m16:16* and *m16:32* operands are memory locations which contain full pointers.

*m16&32, m16&16, m32&32*

is a memory operand consisting of paired data items whose sizes are indicated on the left and the right side of the ampersand. All memory addressing forms are allowed. An *m16&16* or *m32&32* operand is used by the `BOUND` instruction (the operand specifies upper and lower bounds for array indices). `LIDT m16&32` and `LGDT m16&32` load a word into the limit field, and a dword into the base field of the Interrupt and Global Descriptor Table registers. For example, `LGDT m16&32` can be coded

```
LGDT GLOBAL_ARRAY
```

if the following statement appears in a data segment elsewhere in the program (and is followed by the array initializations)

```
GLOBAL_ARRAY LABEL BYTE
```

```
LIDT m16&32 can be coded
```

```
LIDT [BP].IPT_TABLE
```

where `IPT_TABLE` is the element of a structure addressed by the `BP` register.

*moffs8, moffs16, moffs32*

(memory offset) is a simple memory variable of type `BYTE`, `WORD`, or `DWORD` used by the `MOV` instruction. A simple offset relative to the segment base specifies the actual address. No `ModRM` byte is used in the instruction. The number shown with *moffs* indicates its size, which is determined by the address size attribute of the instruction. For example, the instruction `MOV moffs32, EAX` can be coded

```
MOV ITEM_COUNT, EAX
```

where `ITEM_COUNT` is a simple dword memory variable. These special forms of the `MOV` instruction generate less code.

*Sreg*

is a segment register. The segment register values are `ES=0`, `CS=1`, `SS=2`, `DS=3`, `FS=4`, and `GS=5`.

## Clocks Column

The clocks column gives the number of clock cycles for each form of the instruction. The clock values apply only to the Intel386 processor. Instructions which are not available on the Intel386 or 376 processors have a dash (—) in the clocks column.

The clock count calculations make the following assumptions:

1. The instruction has been prefetched and decoded and is ready for execution.
2. Bus cycles do not require wait states.
3. There are no numeric coprocessor data transfers or local bus HOLD requests delaying processor access to the bus.
4. No exceptions are detected during instruction execution.
5. Memory operands are aligned on 4-byte boundaries.

| Opcode          | Instruction                    | Clocks | Description                            |
|-----------------|--------------------------------|--------|----------------------------------------|
| 0C <i>ib</i>    | OR AL, <i>imm8</i>             | 2      | OR immediate byte to AL                |
| 0D <i>iw</i>    | OR AX, <i>imm16</i>            | 2      | OR immediate word to AX                |
| 0D <i>id</i>    | OR EAX, <i>imm32</i>           | 2      | OR immediate dword to EAX              |
| 80 /1 <i>ib</i> | OR <i>r/m8</i> , <i>imm8</i>   | 2/7    | OR immediate byte to <i>r/m</i> byte   |
| 81 /1 <i>iw</i> | OR <i>r/m16</i> , <i>imm16</i> | 2/7    | OR immediate word to <i>r/m</i> word   |
| 81 /1 <i>id</i> | OR <i>r/m32</i> , <i>imm32</i> | 2/7    | OR immediate dword to <i>r/m</i> dword |
| 08 / <i>r</i>   | OR <i>r/m8</i> , <i>r8</i>     | 2/6    | OR byte register to <i>r/m</i> byte    |
| 09 / <i>r</i>   | OR <i>r/m16</i> , <i>r16</i>   | 2/6    | OR word register to <i>r/m</i> word    |
| 09 / <i>r</i>   | OR <i>r/m32</i> , <i>r32</i>   | 2/6    | OR dword register to <i>r/m</i> dword  |
| 0A / <i>r</i>   | OR <i>r8</i> , <i>r/m8</i>     | 2/7    | OR <i>r/m</i> byte to byte register    |
| 0B / <i>r</i>   | OR <i>r16</i> , <i>r/m16</i>   | 2/7    | OR <i>r/m</i> word to word register    |
| 0B / <i>r</i>   | OR <i>r32</i> , <i>r/m32</i>   | 2/7    | OR <i>r/m</i> dword to dword register  |

Clock counts for instructions that have an *r/m* (register or memory) operand are separated by a slash. The count to the left is used for a register operand; the count to the right is used for a memory operand.

The following symbols are used in the clock count specifications:

- $N$  or  $n$  represents the number of times a clock cycle is repeated.
- $m$  represents the number of components in the next instruction executed, where the entire displacement (if any) counts as one component, and all other bytes of the instruction and prefix(es) each count as one component.
- $pm =$  is a label that applies when the instruction executes in protected mode.  $pm =$  is omitted when the clock counts are the same for protected, real address, and virtual 8086 modes.
- † or ‡ indicates additional information about clock counts below the table.

## Description Column

The description column briefly explains the various forms of the instruction.

The Operation and Discussion sections that follow the table contain more details of the instruction's operation.

## Operation Section

This reference page section contains an algorithmic description of the instruction coded in a notation similar to the Algol languages. The algorithms are composed of the following elements:

1. Keywords of the algorithmic language, labels, and processor registers are capitalized; variables, functions, and prose descriptions are in capital and lower case letters. Comments are enclosed within the symbol pairs (\* and \*). Semi-colons separate the statements of the algorithms.
2. Compound statements are indented; compound statements are sometimes terminated by `ENDIF`, `ENDIFELSE`, `ENDWHILE`, or `ENDFOR` for clarity or if their component statements extend across page breaks.
3. A register name implies the contents of the register. A register name enclosed in brackets ([ ]) implies the contents of the location whose address is contained in that register. For example, `ES:[DI]` indicates the contents of the location whose ES segment relative address is in register DI. `[SI]` indicates the contents of the address contained in register SI relative to SI's default segment (DS) or overridden segment.
4. `:=` is the assignment operator. For example, `A:= B`; indicates that the value of B is assigned to A.

5. =, NOT =, >, >=, <, and <= are relational operators used to compare two values. These operators mean "equal, not equal, greater than, greater or equal, less than, less or equal," respectively. A relational expression such as A = B is TRUE if the value of A is equal to that of B; otherwise, it is FALSE.
6. OperandSize represents the 16- or 32-bit operand size attribute of an instruction. StackSize represents the 16- or 32-bit stack size attribute of an instruction. AddressSize represents the 16- or 32-bit address size attribute of the instruction. For example,

```

IF instruction = CMPSW THEN
    OperandSize := 16;
ELSE
    IF instruction = CMPSD THEN
        OperandSize := 32;

```

indicates that the assembler will set the operand size attribute according to the mnemonic form of the CMPS instruction used. The Operation sections for certain instructions indicate how the assembler determines these attributes.

See also: OperandSize, StackSize, and AddressSize, Chapter 6

The following functions are used in the algorithmic descriptions:

1. **Truncate**(value) reduces the size of the value to fit in 16-bits by discarding high-order bits as needed.
2. **Addr**(operand) returns the effective address of the operand. (This value is the address calculation prior to adding the segment base).
3. **ZeroExtend**(value) returns a value zero-extended to the operand size attribute of the instruction. For example, ZeroExtend of a byte-long -10D value converts the byte from F6H to 000000F6H. If the value passed to ZeroExtend and the operand size attribute are the same size, ZeroExtend returns the value unaltered.
4. **SignExtend**(value) returns a value sign-extended to the operand size attribute of the instruction. For example, SignExtend of a byte-long -10D converts the byte from F6H to FFFFFFF6H. If the value passed to SignExtend and the operand size attribute are the same size, SignExtend returns the value unaltered.
5. **Push**(value) pushes a value onto the stack. The number of bytes pushed is determined by the operand size attribute of the instruction.

See also: PUSH instruction, in this chapter

6. **Pop**(value) removes the value from the top of the stack and returns it. The statement

```
EAX := Pop ();
```

assigns the 32-bit value that Pop took from the top of the stack to the EAX register. Pop will return either a word or a dword depending on the operand size attribute.

See also: POP instruction, in this chapter

7. **Bit**[BitBase,BitOffset] returns the address of a bit within a bit string. Bits are numbered from right to left within registers and within memory bytes. If the base operand is a 32-bit register, the offset can be in the range 0..31. This offset addresses a bit within the indicated register. An example, `BIT[EAX, 21]`, is illustrated in Figure 6-3.

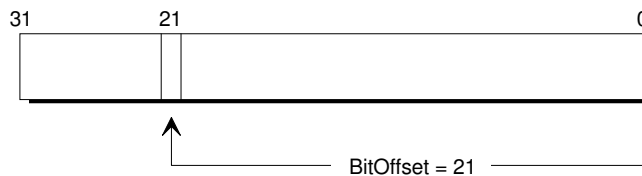

W-3424

**Figure 6-3. BitOffset for BIT[EAX,21]**

In memory, the 2 bytes of a word are stored with the low-order byte at the lower address. If BitBase is a memory address, BitOffset can range from -2 gigabits to +2 gigabits. The addressed bit is numbered (BitOffset MOD 8) within the byte at address (BitBase + (BitOffset DIV 8)), where DIV is signed division with rounding towards negative infinity, and MOD returns a positive number. This is illustrated in Figure 6-4.

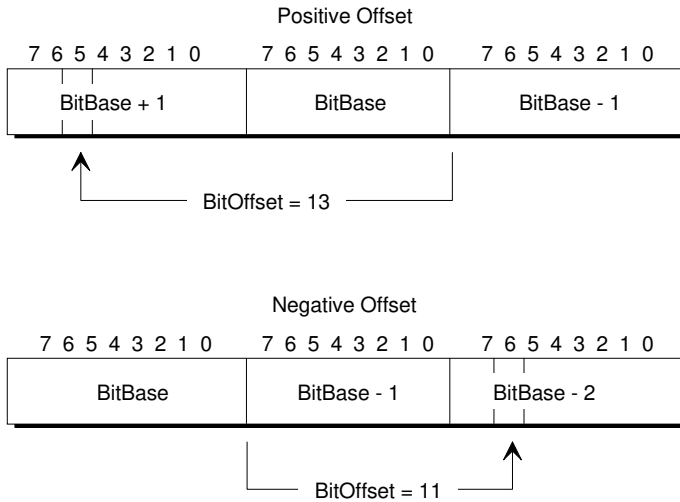

W-3425

**Figure 6-4. Memory Bit Indexing**

8. **IOPermission**(Src, width(Src) ) checks the I/O permission bits for every byte of the Src operand before external I/O operations.

See also: I/O permission bit map, Appendix A

9. **SwitchTasks** performs certain protected mode checks before the processor changes the value of CS: (E) IP. Before the processor executes a CALL, RET, INT, IRET, or JMP instruction in protected mode, it checks the access rights (AR) of the descriptor table entry for the selector associated with the new CS. AR determines whether an intersegment control transfer is:
  - Through a gate
  - A task switch
  - Merely a FAR jump to a code segment at the same privilege level

The SwitchTasks function is an abbreviation for the following checks and actions:

```

IF new TSS descriptor NOT PRESENT (*P bit of AR = 0*) THEN
    #NP(new TSS);
IF new TSS descriptor BUSY (*B bit of AR = 1*) THEN
    #GP(new TSS);
IF new TSS descriptor limit < 103 (*or < 43 for 286 TSS*) THEN
    #TS(new TSS);

```

```

Save machine state in current TSS;
(*copy general, segment, and flags registers to current TSS*)
IF nesting tasks THEN
    new TSS backlink := current TSS selector;
ELSE (*in current TSS descriptor*)
    AR := NOT BUSY; (*B bit = 0*)
ENDIFELSE;
TR (*task register*) := new TSS selector;
new TSS descriptor := BUSY; (*B bit of AR = 1*)
TS (*flag in MSW of CRO*) := 1;
Set general and EFLAGS (*NT := 1 if nested task*) registers
    to new TSS values;
Load selectors for LDT, SS, CS, DS, ES, FS, GS, and, if paging
    enabled, CR3 page directory physical address associated with
    new TSS;
(*Check validity of selectors for LDT and Sreges; if paging
    enabled, check CR3 associated with new TSS*)
(*Check LDT validity: *)
    IF LDT selector NOT within GDT limits
    OR LDT selector does not index GDT THEN
        #TS(LDT selector);
    IF AR (*of LDT descriptor*) indicates non-LDT segment THEN
        #TS(LDT selector);
    IF AR (*of LDT descriptor*) indicates NOT PRESENT THEN
        #TS(LDT selector);
(*END check LDT validity*)
Load new LDT descriptor into LDT cache; (*valid LDT*)
CPL (*of new TSS*) := RPL; (*of new TSS CS selector*)
(*Check validity CS: *)
    IF CS selector = null THEN #TS(CS selector);
    IF CS selector NOT within its descriptor table limits THEN
        #TS(CS selector);
    IF AR (*of CS descriptor*) indicates non-code segment THEN
        #TS(CS selector);
    IF nonconforming AND DPL NOT = CPL THEN #TS(CS selector);
    IF conforming AND DPL > CPL THEN #TS(CS selector);
    IF AR (*of CS descriptor*) indicates NOT PRESENT THEN
        #NP(CS selector);
(*END checks CS validity*)

```

```

Load new CS descriptor into CS cache; (*valid CS*)
(*Check validity SS: *)
    IF new SS selector = null THEN #TS(SS selector):
    IF SS selector NOT within its descriptor table limits THEN
        #TS(SS selector);
    IF RPL (*of SS selector*) NOT = CPL THEN #TS(SS selector);
    IF DPL (*of SS descriptor*) NOT = CPL THEN #TS(SS selector);
    IF AR (*of SS descriptor*) indicates code
    OR non-writable data segment THEN
        #TS(SS selector);
    IF AR (*of SS descriptor*) indicates NOT PRESENT THEN
        #NP(SS selector);
(*END checks SS validity*)
Load new SS descriptor into SS cache; (*valid SS*)
(*Check each of DS, ES, FS, GS segment selector(s) validity*)
IF selector index NOT within its descriptor table limits THEN
    #TS(segment selector);
IF AR (*of new selector*) indicates non-data
OR non-readable code segment THEN
    #TS(segment selector);
IF data OR nonconforming code THEN
    IF DPL < CPL THEN #GP(segment selector);
    IF DPL < RPL THEN #GP(segment selector);
ENDIF; (*data or nonconforming code*)
IF AR (*of segment descriptor*) indicates NOT PRESENT THEN
    #NP(segment selector);
(*END checks DS, ES, FS, GS validity*)
Load new segment descriptor(s) into Sreg cache(s); (*valid
    DS,ES,FS,GS*)
IF PG (*bit 31 of CR0*) = 1 THEN (*paging enabled*)
    IF current TSS CR3 = new TSS CR3 THEN
        NOP;
    ELSE
        Flush page translation cache;
        Load CR3 (*of new TSS*);
    ENDIF; (*page directory base address in CR3*)

```

## Discussion Section

This section contains a further explanation of the instruction's operation.

## Flags Affected Section

This section lists the flags that are affected by the instruction, as follows:

- If a flag is always cleared or always set by the instruction, the flag's value (=0 or =1) is also listed.
- If a flag is undefined, its value may be changed by the instruction in an indeterminate manner.

Most processor instructions assign values to flags in a uniform manner. See each instruction's Operation section for any unconventional flag value assignments it makes. If a flag is not mentioned in the Flags Affected section, the instruction leaves it unchanged.

See also: Flags, Appendix A

## Exceptions by Mode Section

This section lists the exceptions that can occur when the instruction executes. Each processor operating mode can generate different exceptions:

**Protected** This subsection lists the exceptions that can occur when the instruction executes in protected mode. If you write applications in a protected mode environment, consult your operating system documentation to determine what is done when processor exceptions occur.

### Real Address

This subsection lists the exceptions that can occur when the instruction executes in real address mode. This mode has fewer exception conditions than protected mode. Real address mode exceptions do not pass error codes to interrupt procedures.

One possible exception for many instructions is Interrupt 13. The processor generates an Interrupt 13 whenever a memory operand is partly or wholly accessed from the effective address 0FFFFH in a segment. This exception occurs because the second byte of the word is at location 10000H, not at 0; thus, it exceeds the segment's addressability limit.

## Virtual 8086

This subsection lists the exceptions that can occur when the instruction executes in virtual 8086 mode. Virtual 8086 mode allows the processor to simulate virtual 8086 machines. Virtual 8086 mode exceptions are the same as those for Real 8086, with the following additions:

- I/O instructions cause a #GP(0) exception if the IOPL (I/O privilege level) is less than 3 and an I/O permission bit is set.
- Memory references can cause page faults, noted in the reference pages as #PF(fault-code).

When a virtual 8086 mode exception occurs, the processor is set to protected mode.

Processor exception names are formed from a cross-hatch character (#) followed by 2 letters and an optional error code in parentheses. Table 6-16 summarizes the processor exceptions.

**Table 6-16. Processor Exceptions and Interrupts**

| <b>Name</b> | <b>Cause</b>                     | <b>Interrupt Number</b> | <b>Instruction that May Generate this Interrupt</b>                      |
|-------------|----------------------------------|-------------------------|--------------------------------------------------------------------------|
|             | Divide error                     | 0                       | DIV, IDIV                                                                |
|             | Debug exceptions                 | 1                       | Any instruction                                                          |
|             | 1-byte INT opcode                | 3                       | INT                                                                      |
|             | 2-byte interrupt                 | 32-255                  | INT number                                                               |
|             | Interrupt on overflow            | 4                       | INTO                                                                     |
|             | Array bounds check               | 5                       | BOUND                                                                    |
| UD          | Invalid opcode                   | 6                       | Any illegal instruction                                                  |
| #NM         | No math unit available           | 7                       | ESC, WAIT                                                                |
| #DF         | Double fault                     | 8                       | Any instruction that can generate an exception                           |
|             | Coprocessor segment overrun      | 9                       | Any operand to an ESC instruction that wraps around the end of a segment |
| #TS         | Invalid task state segment (TSS) | 10                      | JMP, CALL, any interrupt, IRET                                           |
| #NP         | Segment/gate not present         | 11                      | Any segment register modifier                                            |
| #SS         | Stack fault                      | 12                      | Any instruction that references memory through the SS segment register   |
| #GP         | General protection fault         | 13                      | Any memory reference instruction or code fetch                           |
| #PF         | Page fault                       | 14                      | Any memory reference instruction or code fetch                           |
| #MF         | Math fault                       | 16                      | ESC, WAIT                                                                |

See also: Processor exceptions, Appendix A

## How to Look Up an Instruction

The processor instructions are presented in mnemonic alphabetical order, with the following exceptions:

- Floating-point instructions (ESC instructions for the a numeric coprocessor) are at the end of Chapter 7.
- String handling instructions that have byte, word, and dword variants (with suffixes B, W, and D, respectively) are grouped with the basic instruction form.

The REP prefix variants for string instructions are also grouped. See the following instructions for the variants that are listed on the right:

|      |                              |
|------|------------------------------|
| CMPS | CMPSB, CMPSW, and CMPSD      |
| INS  | INSB, INSW, and INSD         |
| LODS | LODSB, LODSW, and LODSD      |
| MOVS | MOVSB, MOVSW, and MOVSD      |
| OUTS | OUTSB, OUTSW, and OUTSD      |
| SCAS | SCASB, SCASW, and SCASD      |
| STOS | STOSB, STOSW, and STOSD      |
| REP  | REPE, REPZ, REPNE, and REPNZ |

- Some conversion instructions are grouped. See the following instructions for the variant listed on the right:

|     |      |
|-----|------|
| CBW | CWDE |
| CWD | CDQ  |

- See the JCC and SETCC instruction tables for the many variant forms of these conditional instructions. See LOOP for the LOOPcond variants.
- See the following instructions for the variants listed on the right:

|       |        |
|-------|--------|
| INT   | INTO   |
| IRET  | IRETD  |
| POPA  | POPAD  |
| PUSHA | PUSHAD |
| POPF  | POPFD  |
| PUSHF | PUSHFD |
| XLAT  | XLATB  |

- Some load and store instructions are grouped. See the following instructions for those listed on the right:

|       |                         |
|-------|-------------------------|
| LGDT  | LIDT                    |
| LGDTW | LGDTD, LIDTW, and LIDTD |
| SGDT  | SIDT                    |
| SGDTW | SGDTD, SIDTW, and SIDTD |
| LDS   | LES, LFS, LGS and LSS   |

- The rotate instructions and some of the shift instructions are grouped. See the following instructions for those listed on the right:

|     |                   |
|-----|-------------------|
| RCL | RCR, ROL, and ROR |
| SAL | SAR, SHL, and SHR |

- See `VERR` for the `VERW` instruction.

The remainder of this chapter consists of the processor instruction reference pages in mnemonic alphabetical order.

## Processor Instructions

### AAA ASCII Adjust after Addition

| Opcode | Instruction | Clocks | Description                    |
|--------|-------------|--------|--------------------------------|
| 37     | AAA         | 4      | ASCII adjust AL after addition |

### Operation

```
IF ((AL AND 0FH) > 9) OR (AF = 1) THEN
    AL := AL + 6;
    AH := AH + 1;
    AF := 1;
    CF := 1;
ELSE
    CF := 0;
    AF := 0;
ENDIFELSE;
AL := AL AND 0FH;
```

### Discussion

Code `AAA` only following an `ADD` instruction that leaves a byte result in the `AL` register. The lower nibbles of the `ADD` operands should be in the range 0 through 9 (BCD digits) so that `AAA` adjusts `AL` to contain the correct decimal digit result. If `ADD` produced a decimal carry, `AAA` increments the `AH` register and sets the carry (`CF`) and auxiliary carry (`AF`) flags to 1. If `ADD` produced no decimal carry, `AAA` clears the carry and auxiliary flags (0) and leaves `AH` unchanged. In either case, `AL` is left with its upper nibble set to 0. To convert `AL` to an ASCII result, follow the `AAA` instruction with `OR AL, 30H`.

### Flags Affected

`AF` and `CF` as described in the Discussion section; `OF`, `SF`, `ZF`, and `PF` are undefined.

### Exceptions by Mode

#### Protected

None

**Real Address**

None

**Virtual 8086**

None

## AAD ASCII Adjust AX before Division

| Opcode | Instruction | Clocks | Description                     |
|--------|-------------|--------|---------------------------------|
| D5 0A  | AAD         | 19     | ASCII adjust AX before division |

### Operation

```
AL := AH * 0AH + AL;  
AH := 0;
```

### Discussion

AAD prepares 2 unpacked BCD digits (the least significant digit in AL, the most significant digit in AH) for a division operation that will yield an unpacked result. This is done by setting AL to  $AL + (10 * AH)$ , and then setting AH to 0. AX is then equal to the binary equivalent of the original unpacked 2-digit number.

### Flags Affected

SF, ZF, and PF as described in Appendix A; OF, AF, and CF are undefined

### Exceptions by Mode

#### Protected

None

#### Real Address

None

#### Virtual 8086

None

## AAM ASCII Adjust AX after Multiply

| Opcode | Instruction | Clocks | Description                    |
|--------|-------------|--------|--------------------------------|
| D4 0A  | AAM         | 17     | ASCII adjust AX after multiply |

### Operation

```
AH := AL / 0AH;  
AL := AL MOD 0AH;
```

### Discussion

Code `AAM` only following a `MUL` instruction on two unpacked BCD digits that leaves the result in the AX register. AL contains the `MUL` result, because it is always less than 100. `AAM` unpacks this result by dividing AL by 10, leaving the quotient (most significant digit) in AH and the remainder (least significant digit) in AL.

### Flags Affected

F, ZF, and PF as described in Appendix A; OF, AF, and CF are undefined

### Exceptions by Mode

#### Protected

None

#### Real Address

None

#### Virtual 8086

None

## AAS ASCII Adjust AL after Subtraction

| Opcode | Instruction | Clocks | Description                       |
|--------|-------------|--------|-----------------------------------|
| 3F     | AAS         | 4      | ASCII adjust AL after subtraction |

### Operation

```
IF (AL AND 0FH) > 9 OR AF = 1 THEN
    AL := AL - 6;
    AH := AH - 1;
    AF := 1;
    CF := 1;
ELSE
    CF := 0;
    AF := 0;
ENDIFELSE;
AL := AL AND 0FH;
```

### Discussion

Code `AAS` only following a `SUB` instruction that leaves the byte result in the `AL` register. The lower nibbles of the `SUB` operands should be in the range 0 through 9 (BCD digits) so that `AAS` adjusts `AL` to contain the correct decimal digit result. If `SUB` produced a decimal carry, `AAS` decrements the `AH` register and sets the carry (`CF`) and auxiliary carry (`AF`) flags to 1. If `SUB` produced no decimal carry, `AAS` clears the carry and auxiliary carry flags (0) and leaves `AH` unchanged. In either case, `AL` is left with its upper nibble set to 0. To convert `AL` to an ASCII result, follow the `AAS` with `OR AL, 30H`.

### Flags Affected

`AF` and `CF` as described in the Discussion section; `OF`, `SF`, `ZF`, and `PF` are undefined

### Exceptions by Mode

#### Protected

None

**Real Address**

None

**Virtual 8086**

None

**ADC** Add with Carry

| Opcode          | Instruction                     | Clocks | Description                                                       |
|-----------------|---------------------------------|--------|-------------------------------------------------------------------|
| 14 <i>ib</i>    | ADC AL, <i>imm8</i>             | 2      | Add with carry immediate byte to AL                               |
| 15 <i>iw</i>    | ADC AX, <i>imm16</i>            | 2      | Add with carry immediate word to AX                               |
| 15 <i>id</i>    | ADC EAX, <i>imm32</i>           | 2      | Add with carry immediate dword to EAX                             |
| 80 /2 <i>ib</i> | ADC <i>r/m8</i> , <i>imm8</i>   | 2/7    | Add with carry immediate byte to <i>r/m</i> byte                  |
| 81 /2 <i>iw</i> | ADC <i>r/m16</i> , <i>imm16</i> | 2/7    | Add with carry immediate word to <i>r/m</i> word                  |
| 81 /2 <i>id</i> | ADC <i>r/m32</i> , <i>imm32</i> | 2/7    | Add with carry immediate dword to <i>r/m</i> dword                |
| 83 /2 <i>ib</i> | ADC <i>r/m16</i> , <i>imm8</i>  | 2/7    | Add with carry sign-extended immediate byte to <i>r/m</i> word    |
| 83 /2 <i>ib</i> | ADC <i>r/m32</i> , <i>imm8</i>  | 2/7    | Add with carry sign-extended immediate byte into <i>r/m</i> dword |
| 10 / <i>r</i>   | ADC <i>r/m8</i> , <i>r8</i>     | 2/7    | Add with carry byte register to <i>r/m</i> byte                   |
| 11 / <i>r</i>   | ADC <i>r/m16</i> , <i>r16</i>   | 2/7    | Add with carry word register to <i>r/m</i> word                   |
| 11 / <i>r</i>   | ADC <i>r/m32</i> , <i>r32</i>   | 2/7    | Add with carry dword register to <i>r/m</i> dword                 |
| 12 / <i>r</i>   | ADC <i>r8</i> , <i>r/m8</i>     | 2/6    | Add with carry <i>r/m</i> byte to byte register                   |
| 13 / <i>r</i>   | ADC <i>r16</i> , <i>r/m16</i>   | 2/6    | Add with carry <i>r/m</i> word to word register                   |
| 13 / <i>r</i>   | ADC <i>r32</i> , <i>r/m32</i>   | 2/6    | Add with CF <i>r/m</i> dword to dword register                    |

**Operation**

```

IF (Src is byte) AND (Dest is word or dword) THEN
    Dest := Dest + SignExtend(Src) + CF;
ELSE
    Dest := Dest + Src + CF;

```

**Discussion**

ADC performs integer addition of the two operands, Dest and Src, and of the carry flag, CF. ADC assigns the result to the first operand (Dest), and sets the flags accordingly. ADC is usually executed as part of a multi-byte or multi-word addition operation. When an immediate byte value is added to a word or dword operand, the immediate value is first sign-extended to the size of the operand.

---

## Flags Affected

OF, SF, ZF, AF, CF, and PF as described in Appendix A

## Exceptions by Mode

### Protected

#GP(0) if the result is in a nonwritable segment; #GP(0) for an illegal memory operand effective address in the CS, DS, ES, FS, or GS segments; #SS(0) for an illegal address in the SS segment; #PF(fault-code) if page fault

### Real Address

Interrupt 13 if any part of the operand would lie outside the effective address space from 0 to 0FFFFH

### Virtual 8086

Same as Real Address Mode; #PF(fault-code) for a page fault

## ADD

---

### ADD (Integer) Add

| Opcode          | Instruction                     | Clocks | Description                                          |
|-----------------|---------------------------------|--------|------------------------------------------------------|
| 04 <i>ib</i>    | ADD AL, <i>imm8</i>             | 2      | Add immediate byte to AL                             |
| 05 <i>iw</i>    | ADD AX, <i>imm16</i>            | 2      | Add immediate word to AX                             |
| 05 <i>id</i>    | ADD EAX, <i>imm32</i>           | 2      | Add immediate dword to EAX                           |
| 80 /0 <i>ib</i> | ADD <i>r/m8</i> , <i>imm8</i>   | 2/7    | Add immediate byte to <i>r/m</i> byte                |
| 81 /0 <i>iw</i> | ADD <i>r/m16</i> , <i>imm16</i> | 2/7    | Add immediate word to <i>r/m</i> word                |
| 81 /0 <i>id</i> | ADD <i>r/m32</i> , <i>imm32</i> | 2/7    | Add immediate dword to <i>r/m</i> dword              |
| 83 /0 <i>ib</i> | ADD <i>r/m16</i> , <i>imm8</i>  | 2/7    | Add sign-extended immediate byte to <i>r/m</i> word  |
| 83 /0 <i>ib</i> | ADD <i>r/m32</i> , <i>imm8</i>  | 2/7    | Add sign-extended immediate byte to <i>r/m</i> dword |
| 00 / <i>r</i>   | ADD <i>r/m8</i> , <i>r8</i>     | 2/7    | Add byte register to <i>r/m</i> byte                 |
| 01 / <i>r</i>   | ADD <i>r/m16</i> , <i>r16</i>   | 2/7    | Add word register to <i>r/m</i> word                 |
| 01 / <i>r</i>   | ADD <i>r/m32</i> , <i>r32</i>   | 2/7    | Add dword register to <i>r/m</i> dword               |
| 02 / <i>r</i>   | ADD <i>r8</i> , <i>r/m8</i>     | 2/6    | Add <i>r/m</i> byte to byte register                 |
| 03 / <i>r</i>   | ADD <i>r16</i> , <i>r/m16</i>   | 2/6    | Add <i>r/m</i> word to word register                 |
| 03 / <i>r</i>   | ADD <i>r32</i> , <i>r/m32</i>   | 2/7    | Add <i>r/m</i> dword to dword register               |

### Operation

```
IF (Src is byte) AND (Dest is word or dword) THEN
    Dest := Dest + SignExtend(Src);
ELSE
    Dest := Dest + Src;
```

### Discussion

ADD performs integer addition of the two operands. ADD assigns the result to the first operand (Dest) and sets the flags accordingly. When an immediate byte is added to a word or dword operand, the immediate value is sign-extended to the size of the operand.

### Flags Affected

OF, SF, ZF, AF, CF, and PF as described in Appendix A

## Exceptions by Mode

### Protected

#GP(0) if the result is in a nonwritable segment; #GP(0) for an illegal memory operand effective address in the CS, DS, ES, FS, or GS segments; #SS(0) for an illegal address in the SS segment; #PF(fault-code) for a page fault

### Real Address

Interrupt 13 if any part of the operand would lie outside the effective address space from 0 to 0FFFFH

### Virtual 8086

Same as Real Address Mode; #PF(fault-code) for a page fault

## AND Logical AND

| Opcode          | Instruction                     | Clocks | Description                                |
|-----------------|---------------------------------|--------|--------------------------------------------|
| 24 <i>ib</i>    | AND AL, <i>imm8</i>             | 2      | AND immediate byte to AL                   |
| 25 <i>iw</i>    | AND AX, <i>imm16</i>            | 2      | AND immediate word to AX                   |
| 25 <i>id</i>    | AND EAX, <i>imm32</i>           | 2      | AND immediate dword to EAX                 |
| 80 /4 <i>ib</i> | AND <i>r/m8</i> , <i>imm8</i>   | 2/7    | AND immediate byte to <i>r/m</i> byte      |
| 81 /4 <i>iw</i> | AND <i>r/m16</i> , <i>imm16</i> | 2/7    | AND immediate word to <i>r/m</i> word      |
| 81 /4 <i>id</i> | AND <i>r/m32</i> , <i>imm32</i> | 2/7    | AND immediate dword to <i>r/m</i> dword    |
| 83 /4 <i>ib</i> | AND <i>r/m16</i> , <i>imm8</i>  | 2/7    | AND sign-extended byte to <i>r/m</i> word  |
| 83 /4 <i>ib</i> | AND <i>r/m32</i> , <i>imm8</i>  | 2/7    | AND sign-extended byte to <i>r/m</i> dword |
| 20 / <i>r</i>   | AND <i>r/m8</i> , <i>r8</i>     | 2/7    | AND byte register to <i>r/m</i> byte       |
| 21 / <i>r</i>   | AND <i>r/m16</i> , <i>r16</i>   | 2/7    | AND word register to <i>r/m</i> word       |
| 21 / <i>r</i>   | AND <i>r/m32</i> , <i>r32</i>   | 2/7    | AND dword register to <i>r/m</i> dword     |
| 22 / <i>r</i>   | AND <i>r8</i> , <i>r/m8</i>     | 2/6    | AND <i>r/m</i> byte to byte register       |
| 23 / <i>r</i>   | AND <i>r16</i> , <i>r/m16</i>   | 2/6    | AND <i>r/m</i> word to word register       |
| 23 / <i>r</i>   | AND <i>r32</i> , <i>r/m32</i>   | 2/6    | AND <i>r/m</i> dword to dword register     |

## Operation

```
Dest := Dest AND Src;  
CF := 0;  
OF := 0;
```

## Discussion

If corresponding bits of the operands are both 1, AND sets the corresponding result bit to 1. Otherwise, AND sets the corresponding result bit to 0.

## Flags Affected

CF = 0, OF = 0; PF, SF, and ZF as described in Appendix A

## Exceptions by Mode

### Protected

#GP(0) if the result is in a nonwritable segment; #GP(0) for an illegal memory operand effective address in the CS, DS, ES, FS, or GS segments; #SS(0) for an illegal address in the SS segment; #PF(fault-code) for a page fault

### Real Address

Interrupt 13 if any part of the operand would lie outside the effective address space from 0 to 0FFFFH

### Virtual 8086

Same as Real Address Mode; #PF(fault-code) for a page fault

## ARPL Adjust RPL Field of Selector

| Opcode | Instruction           | Clocks          | Description                                                   |
|--------|-----------------------|-----------------|---------------------------------------------------------------|
| 63 /r  | ARPL <i>r/m16,r16</i> | <i>pm=20/21</i> | Adjust RPL of <i>r/m16</i> to not less than RPL of <i>r16</i> |

## Operation

```
IF RPL (*bits 0,1*) of Dest < RPL (*bits 0,1*) of Src THEN
    ZF := 1;
    RPL (*bits 0,1*) of Dest := RPL (*bits 0,1*) of Src;
ELSE
    ZF := 0;
```

## Discussion

The ARPL instruction has 2 operands:

1. The first operand is a 16-bit memory variable or word register that contains the value of a selector.
2. The second operand is a word register that also contains a selector.

If the RPL field (requesting privilege level -- lower two bits) of the first operand is less than the RPL field of the second operand, ARPL sets ZF to 1 and increases the RPL field of the first operand to match that of the second operand. Otherwise, ARPL clears ZF (0) and makes no change in the first operand.

ARPL appears only in operating system software. It is used to guarantee that a selector parameter to a subroutine does not request more privilege than the caller is allowed. The second operand of ARPL is normally a register that contains the CS selector value of the caller.

## Flags Affected

ZF as described in the Discussion section

## Exceptions by Mode

### Protected

#GP(0) if the result is in a nonwritable segment; #GP(0) for an illegal memory operand effective address in the CS, DS, ES, FS, or GS segments; #SS(0) for an illegal address in the SS segment; #PF(fault-code) for a page fault

**Real Address**

Interrupt 6

**Virtual 8086**

Interrupt 6; #PF(fault-code) for a page fault

## BOUND Check Array Index Against Bounds

| Opcode | Instruction        | Clocks          | Description                                                      |
|--------|--------------------|-----------------|------------------------------------------------------------------|
| 62 /r  | BOUND <i>r16</i> , | 10 <sup>†</sup> | Interrupt 5 if <i>r16</i> is not within bounds <i>m16&amp;16</i> |
| 62 /r  | BOUND <i>r32</i> , | 10 <sup>†</sup> | Interrupt 5 if <i>r32</i> is not within bounds <i>m32&amp;32</i> |

<sup>†</sup> Does not include clocks for Interrupt 5.

### Operation

```
IF (LeftSrc < [RightSrc] (* lower limit *)
    OR LeftSrc > [RightSrc + OperandSize/8] ) (* upper limit *)
THEN Interrupt 5;
```

### Discussion

BOUND checks that a signed array index is within limits. The register operand contains the index. Contiguous dword or word operands specify the lower and upper limits. If the index is not within bounds, an Interrupt 5 occurs; the return EIP points to the BOUND instruction. The second operand must be a memory operand, not a register.

The bounds limit data structure can be placed in memory just before the array itself. This makes the limits addressable via a constant offset from the beginning of the array.

### Flags Affected

None

### Exceptions by Mode

#### Protected

Interrupt 5 if the bounds test fails; #GP(0) for an illegal memory operand effective address in the CS, DS, ES, FS, or GS segments; #SS(0) for an illegal address in the SS segment; #PF(fault-code) for a page fault; #UD if the second operand is a ModRM byte representing a register

## **Real Address**

Interrupt 5 if the bounds test fails; Interrupt 13 if any part of the operand would lie outside the effective address space from 0 to 0FFFFH; Interrupt 6 if the second operand is a register

## **Virtual 8086**

Same as Real Address Mode; #PF(fault-code) for a page fault

**BSF** Bit Scan Forward

| Opcode | Instruction          | Clocks                     | Description                          |
|--------|----------------------|----------------------------|--------------------------------------|
| 0F BC  | BSF <i>r16,r/m16</i> | 10+3 <i>n</i> <sup>†</sup> | Bit scan forward on <i>r/m</i> word  |
| 0F BC  | BSF <i>r32,r/m32</i> | 10+3 <i>n</i> <sup>†</sup> | Bit scan forward on <i>r/m</i> dword |

<sup>†</sup> *n* is the number of leading zero bits.

**Operation**

```
IF r/m = 0 THEN
    ZF := 1;
    register := UNDEFINED;
ELSE
    temp := 0;
    ZF := 0;
    WHILE Bit[r/m,temp] = 0 DO
        temp := temp + 1;
    ENDWHILE;
    register := temp;
```

**Discussion**

BSF scans the bits in the second operand from right to left starting at bit 0. BSF places the index of the first set bit that it finds into the first operand and clears ZF. If no bit is set in the second operand, BSF sets ZF, and the first operand is undefined.

**Flags Affected**

ZF as described in the Discussion section

**Exceptions by Mode****Protected**

#GP(0) for an illegal memory operand effective address in the CS, DS, ES, FS, or GS segments; #SS(0) for an illegal address in the SS segment; #PF(fault-code) for a page fault

## Real Address

Interrupt 13 if any part of the operand would lie outside the effective address space from 0 to 0FFFFH

## Virtual 8086

Same as Real Address Mode; #PF(fault-code) for a page fault

**BSR** Bit Scan Reverse

| Opcode | Instruction          | Clocks             | Description                          |
|--------|----------------------|--------------------|--------------------------------------|
| 0F BD  | BSR <i>r16,r/m16</i> | 10+3 $n^{\dagger}$ | Bit scan reverse on <i>r/m</i> word  |
| 0F BD  | BSR <i>r32,r/m32</i> | 10+3 $n^{\dagger}$ | Bit scan reverse on <i>r/m</i> dword |

$\dagger$  *n* is the number of leading zero bits.

**Operation**

```
IF r/m = 0 THEN
    ZF := 1;
    register := UNDEFINED;
ELSE
    temp := OperandSize - 1;
    ZF := 0;
    WHILE Bit[r/m,temp] = 0 DO
        temp := temp - 1;
    ENDWHILE;
    register := temp;
```

**Discussion**

BSR scans the bits in the second operand from left to right starting at the most significant bit (31 or 15). BSR places the index of the first bit that it finds set into the first operand and clears ZF. If no bit is set, BSR sets ZF, and the first operand is undefined.

**Flags Affected**

ZF as described in the Discussion section

**Exceptions by Mode****Protected**

#GP(0) for an illegal memory operand effective address in the CS, DS, ES, FS, or GS segments; #SS(0) for an illegal address in the SS segment; #PF(fault-code) for a page fault

**Real Address**

Interrupt 13 if any part of the operand would lie outside the effective address space from 0 to 0FFFFH

**Virtual 8086**

Same as Real Address Mode; #PF(fault-code) for a page fault

## BSWAP

Byte Swap (not available on Intel386 or 376 processors)

| Opcode            | Instruction      | Clocks | Description                                                                   |
|-------------------|------------------|--------|-------------------------------------------------------------------------------|
| 0F C8 + <i>rd</i> | BSWAP <i>r32</i> | —      | Swaps <i>r32</i> high byte for low byte, middle-high byte for middle-low byte |

### Operation

```
temp := r 32;  
r 32 [0..7] := temp[24..31];  
r 32 [8..15] := temp[16..23];  
r 32 [16..23] := temp[8..15];  
r 32 [24..31] := temp[0..7];
```

### Discussion

BSWAP swaps the high bytes and low bytes of a 32-bit register. BSWAP takes a single operand as its source and destination.

### Flags Affected

None

### Exceptions by Mode

#### Protected

None

#### Real Address

None

#### Virtual 8086

None

**BT** Bit Test

| Opcode             | Instruction         | Clocks | Description            |
|--------------------|---------------------|--------|------------------------|
| 0F A3 /r           | BT <i>r/m16,r16</i> | 3/12   | Save bit in carry flag |
| 0F A3 /r           | BT <i>r/m32,r32</i> | 3/12   | Save bit in carry flag |
| 0F BA /4 <i>ib</i> | BT <i>r16,imm8</i>  | 3      | Save bit in carry flag |
| 0F BA /4 <i>ib</i> | BT <i>r32,imm8</i>  | 3      | Save bit in carry flag |
| 0F BA /4 <i>ib</i> | BT <i>m,imm16</i>   | 6      | Save bit in carry flag |
| 0F BA /4 <i>ib</i> | BT <i>m,imm32</i>   | 6      | Save bit in carry flag |
| 0F BA /4 <i>ib</i> | BT <i>m</i>         | 6      | Save bit in carry flag |

**Operation**

```
CF := Bit[LeftSrc,RightSrc];
```

**Discussion**

BT copies the value of a selected bit into the carry flag. The BT operands specify:

- A bit string (register first operand) or bit string base address (memory first operand)
- A bit offset (second operand) to the selected bit

If the first operand is a register, the bit offset of the selected bit can be specified as an immediate byte constant as well as a value in a general register. The bit offset is taken modulo the operand size, so the range is 0..31 (or 0..15 for a 16-bit operand).

If the bit string is in memory, the first operand is its base address, and the second operand is an offset relative to this base address. The USE attribute of the first operand determines register size and offset limits for the second operand.

If the first operand is in a USE32 segment, the second operand must be either a dword register, containing a value, or an immediate constant value within the range:

```
-2 gigabits to (+2 gigabits - 1).
```

For non-combinable USE32 segments, assembly time address calculation requires the effective address of the bit string and bit offset to satisfy:

```
0 <= ((effective address * 8) + (bit offset)) < 32 gigabits.
```

If the first operand is in a `USE16` segment, the second operand must be either a word register, containing a value, or an immediate constant value within the range:

`-32 Kbits to (+32 Kbits - 1).`

For non-combinable `USE16` segments, assembly time address calculation requires the effective address of the bit string and bit offset to satisfy:

`0 <= ((effective address * 8) + (bit offset)) < 512 Kbits.`

If the bit string is in memory, the assembler will combine the bit offset with the effective address to generate a dword aligned 32-bit address, or a word aligned 16-bit address, and it will adjust the bit offset accordingly.

When accessing a bit in memory, the processor may access 4 or 2 bytes starting from the memory address:

- `Effective Address + (4 * (BitOffset DIV 32) )` for a 32-bit operand size
- `Effective Address + (2 * (BitOffset DIV 16) )` for a 16-bit operand size

It may do this even when only a single byte needs to be accessed in order to reach the given bit. Therefore, avoid referencing areas of memory close to address space holes. In particular, avoid references to memory-mapped I/O registers. Instead, use the `MOV` instructions to load from these addresses. Then, use a register form of `BT` to manipulate the data.

The `BT m` form (without offset) assumes an operand of type `DBIT`, but the assembler does not check the type. For example,

```
BT BAZ.Y
```

accesses a bit where `BAZ` and `Y` were defined as follows:

```
; structure definition
FOO STRUC
    X DBIT 11 DUP (110B)
    Y DBIT 1B
    Z DBIT 1B
FOO ENDS
;
BAZ FOO <>
```

## Flags Affected

CF as described in the Discussion section; all other flags are undefined

## Exceptions by Mode

### Protected

#GP(0) if the result is in a nonwritable segment; #GP(0) for an illegal memory operand effective address in the CS, DS, ES, FS, or GS segments; #SS(0) for an illegal address in the SS segment; #PF(fault-code) for a page fault

### Real Address

Interrupt 13 if any part of the operand would lie outside the effective address space from 0 to 0FFFFH

### Virtual 8086

Same as Real Address Mode; #PF(fault-code) for a page fault

**BTC** Bit Test and Complement

| Opcode      | Instruction   | Clocks | Description                            |
|-------------|---------------|--------|----------------------------------------|
| 0F BB /r    | BTC r/m16,r16 | 6/13   | Save bit in carry flag; complement bit |
| 0F BB /r    | BTC r/m32,r32 | 6/13   | Save bit in carry flag; complement bit |
| 0F BA /7 ib | BTC r16,imm8  | 6      | Save bit in carry flag; complement bit |
| 0F BA /7 ib | BTC r32,imm8  | 6      | Save bit in carry flag; complement bit |
| 0F BA /7 ib | BTC m,imm16   | 8      | Save bit in carry flag; complement bit |
| 0F BA /7 ib | BTC m,imm32   | 8      | Save bit in carry flag; complement bit |
| 0F BA /7 ib | BTC m         | 8      | Save bit in carry flag; complement bit |

**Operation**

```
CF := Bit[LeftSrc, RightSrc];
Bit[LeftSrc,RightSrc] := NOT Bit[LeftSrc,RightSrc];
```

**Discussion**

BTC copies the value of a selected bit into the carry flag and then complements the bit. The BTC operands specify:

- A bit string (register first operand) or bit string base address (memory first operand)
- A bit offset (second operand) to the selected bit

If the first operand is a register, the bit offset of the selected bit can be specified as an immediate byte constant as well as a value in a general register. The bit offset is taken modulo the operand size, so the range is 0..31 (or 0..15 for a 16-bit operand).

If the bit string is in memory, the first operand is its base address, and the second operand is an offset relative to this base address. The USE attribute of the first operand determines register size and offset limits for the second operand.

If the first operand is in a USE32 segment, the second operand must be either a dword register, containing a value, or an immediate constant value within the range:

```
-2 gigabits to (+2 gigabits - 1).
```

For non-combinable USE32 segments, assembly time address calculation requires the effective address of the bit string and bit offset to satisfy:

```
0 <= ((effective address * 8) + (bit offset)) < 32 gigabits.
```

If the first operand is in a `USE16` segment, the second operand must be either a word register, containing a value, or an immediate constant value within the range:

$$-32 \text{ Kbits to } (+32 \text{ Kbits} - 1).$$

For non-combinable `USE16` segments, assembly time address calculation requires the effective address of the bit string and bit offset to satisfy:

$$0 < = ((\text{effective address} * 8) + (\text{bit offset})) < 512 \text{ Kbits}.$$

If the bit string is in memory, the assembler will combine the bit offset with the effective address to generate a dword aligned 32-bit address, or a word aligned 16-bit address, and it will adjust the bit offset accordingly.

When accessing a bit in memory, the processor may access 4 or 2 bytes starting from the memory address:

- `Effective Address + (4 * (BitOffset DIV 32))` for a 32-bit operand size
- `Effective Address + (2 * (BitOffset DIV 16))` for a 16-bit operand size

It may do this even when only a single byte needs to be accessed in order to reach the given bit. Therefore, avoid referencing areas of memory close to address space holes. In particular, avoid references to memory-mapped I/O registers. Instead, use the `MOV` instructions to load from (or store to) these addresses. Use a register form of `BTC` to manipulate the data.

The `BTC m` form (without offset) assumes an operand of type `DBIT`, but the assembler does not check the type. For example,

```
BTC BAZ.Y
```

accesses a bit where `BAZ` and `Y` were defined as follows:

```
; structure definition
FOO STRUC
    X DBIT 11 DUP (110B)
    Y DBIT 1B
    Z DBIT 1B
FOO ENDS
;
BAZ FOO <>
```

## Flags Affected

CF as described in the Discussion section; the other flags are undefined

## Exceptions by Mode

### Protected

#GP(0) if the result is in a nonwritable segment; #GP(0) for an illegal memory operand effective address in the CS, DS, ES, FS, or GS segments; #SS(0) for an illegal address in the SS segment; #PF(fault-code) for a page fault

### Real Address

Interrupt 13 if any part of the operand would lie outside the effective address space from 0 to 0FFFFH

### Virtual 8086

Same as Real Address Mode; #PF(fault-code) for a page fault

**BTR** Bit Test and Reset

| Opcode             | Instruction          | Clocks | Description                       |
|--------------------|----------------------|--------|-----------------------------------|
| 0F B3 /r           | BTR <i>r/m16,r16</i> | 6/13   | Save bit in carry flag; clear bit |
| 0F B3 /r           | BTR <i>r/m32,r32</i> | 6/13   | Save bit in carry flag; clear bit |
| 0F BA /6 <i>ib</i> | BTR <i>r16,imm8</i>  | 6      | Save bit in carry flag; clear bit |
| 0F BA /6 <i>ib</i> | BTR <i>r32,imm8</i>  | 6      | Save bit in carry flag; clear bit |
| 0F BA /6 <i>ib</i> | BTR <i>m,imm16</i>   | 13     | Save bit in carry flag; clear bit |
| 0F BA /6 <i>ib</i> | BTR <i>m,imm32</i>   | 13     | Save bit in carry flag; clear bit |
| 0F BA /6 <i>ib</i> | BTR <i>m</i>         | 13     | Save bit in carry flag; clear bit |

**Operation**

```
CF := Bit[LeftSrc,RightSrc];
Bit[LeftSrc,RightSrc] := 0;
```

**Discussion**

BTR copies the value of a selected bit into the carry flag and then clears the bit. The BTR operands specify:

- A bit string (register first operand) or bit string base address (memory first operand)
- A bit offset (second operand) to the selected bit

If the first operand is a register, the bit offset of the selected bit can be specified as an immediate byte constant as well as a value in a general register. The bit offset is taken modulo the operand size, so the range is 0..31 (or 0..15 for a 16-bit operand).

If the bit string is in memory, the first operand is its base address, and the second operand is an offset relative to this base address. The USE attribute of the first operand determines register size and offset limits for the second operand.

If the first operand is in a USE32 segment, the second operand must be either a dword register, containing a value, or an immediate constant value within the range:

```
-2 gigabits to (+2 gigabits - 1).
```

For non-combinable `USE32` segments, assembly time address calculation requires the effective address of the bit string and bit offset to satisfy:

```
0 <= ((effective address * 8) + (bit offset)) < 32 gigabits.
```

If the first operand is in a `USE16` segment, the second operand must be either a word register, containing a value, or an immediate constant value within the range:

```
-32 Kbits to (+32 Kbits - 1).
```

For non-combinable `USE16` segments, assembly time address calculation requires the effective address of the bit string and bit offset to satisfy:

```
0 <= ((effective address * 8) + (bit offset)) < 512 Kbits.
```

If the bit string is in memory, the assembler will combine the bit offset with the effective address to generate a dword aligned 32-bit address, or a word aligned 16-bit address, and it will adjust the bit offset accordingly.

When accessing a bit in memory, the processor may access 4 or 2 bytes starting from the memory address:

- Effective Address + (4 \* (BitOffset DIV 32) ) for a 32-bit operand size
- Effective Address + (2 \* (BitOffset DIV 16) ) for a 16-bit operand size

It may do this even when only a single byte needs to be accessed in order to reach the given bit. Therefore, avoid referencing areas of memory close to address space holes. In particular, avoid references to memory-mapped I/O registers. Instead, use the `MOV` instructions to load from (or store to) these addresses. Use a register form of `BTR` to manipulate the data.

The `BTR m` form (without offset) assumes an operand of type `DBIT`, but the assembler does not check the type. For example,

```
BTR BAZ.Y
```

accesses a bit where `BAZ` and `Y` were defined as follows:

```
; structure definition
FOO STRUC
    X DBIT 11 DUP (110B)
    Y DBIT 1B
    Z DBIT 1B
FOO ENDS
;
BAZ FOO <>
```

## Flags Affected

CF as described in the Discussion section; the other flags are undefined

## Exceptions by Mode

### Protected

#GP(0) if the result is in a nonwritable segment; #GP(0) for an illegal memory operand effective address in the CS, DS, ES, FS, or GS segments; #SS(0) for an illegal address in the SS segment; #PF(fault-code) for a page fault

### Real Address

Interrupt 13 if any part of the operand would lie outside the effective address space from 0 to 0FFFFH

### Virtual 8086

Same as Real Address Mode; #PF(fault-code) for a page fault

**BTS** Bit Test and Set

| <b>Opcode</b>      | <b>Instruction</b>   | <b>Clocks</b> | <b>Description</b>              |
|--------------------|----------------------|---------------|---------------------------------|
| 0F AB /r           | BTS <i>r/m16,r16</i> | 6/13          | Save bit in carry flag; set bit |
| 0F AB /r           | BTS <i>r/m32,r32</i> | 6/13          | Save bit in carry flag; set bit |
| 0F BA /5 <i>ib</i> | BTS <i>r16,imm8</i>  | 6             | Save bit in carry flag; set bit |
| 0F BA /5 <i>ib</i> | BTS <i>r32,imm8</i>  | 6             | Save bit in carry flag; set bit |
| 0F BA /5 <i>ib</i> | BTS <i>m,imm16</i>   | 8             | Save bit in carry flag; set bit |
| 0F BA /5 <i>ib</i> | BTS <i>m,imm32</i>   | 8             | Save bit in carry flag; set bit |
| 0F BA /5 <i>ib</i> | BTS <i>m</i>         | 8             | Save bit in carry flag; set bit |

**Operation**

```
CF := Bit[LeftSrc,RightSrc];  
Bit[LeftSrc,RightSrc] := 1;
```

**Discussion**

BTS copies the value of a selected bit into the carry flag and then sets the bit. The BTS operands specify:

- A bit string (register first operand) or bit string base address (memory first operand)
- A bit offset (second operand) to the selected bit

If the first operand is a register, the bit offset of the selected bit can be specified as an immediate byte constant as well as a value in a general register. The bit offset is taken modulo the operand size, so the range is 0..31 (or 0..15 for a 16-bit operand).

If the bit string is in memory, the first operand is its base address, and the second operand is an offset relative to this base address. The `USE` attribute of the first operand determines register size and offset limits for the second operand.

If the first operand is in a `USE32` segment, the second operand must be either a dword register, containing a value, or an immediate constant value within the range:

```
-2 gigabits to (+2 gigabits - 1).
```

For non-combinable `USE32` segments, assembly time address calculation requires the effective address of the bit string and bit offset to satisfy:

$$0 \leq ((\text{effective address} * 8) + (\text{bit offset})) < 32 \text{ gigabits.}$$

If the first operand is in a `USE16` segment, the second operand must be either a word register, containing a value, or an immediate constant value within the range:

$$-32 \text{ Kbits to } (+32 \text{ Kbits} - 1).$$

For non-combinable `USE16` segments, assembly time address calculation requires the effective address of the bit string and bit offset to satisfy:

$$0 \leq ((\text{effective address} * 8) + (\text{bit offset})) < 512 \text{ Kbits.}$$

If the bit string is in memory, the assembler will combine the bit offset with the effective address to generate a dword aligned 32-bit address, or a word aligned 16-bit address, and it will adjust the bit offset accordingly.

When accessing a bit in memory, the processor may access 4 or 2 bytes starting from the memory address:

- Effective Address + (4 \* (BitOffset DIV 32) ) for a 32-bit operand size
- Effective Address + (2 \* (BitOffset DIV 16) ) for a 16-bit operand size

It may do this even when only a single byte needs to be accessed in order to reach the given bit. Therefore, avoid referencing areas of memory close to address space holes. In particular, avoid references to memory-mapped I/O registers. Instead, use the `MOV` instructions to load from (or store to) these addresses. Use a register form of `BTS` to manipulate the data.

The `BTS m` form (without offset) assumes an operand of type `DBIT`, but the assembler does not check the type. For example,

```
BTS BAZ.Y
```

accesses a bit where `BAZ` and `Y` were defined as follows:

```
; structure definition
FOO STRUC
  X DBIT 11 DUP (110B)
  Y DBIT 1B
  Z DBIT 1B
FOO ENDS
;
BAZ FOO <>
```

### Flags Affected

CF as described in the Discussion section; the other flags are undefined

### Exceptions by Mode

#### Protected

#GP(0) if the result is in a nonwritable segment; #GP(0) for an illegal memory operand effective address in the CS, DS, ES, or GS segments; #SS(0) for an illegal address in the SS segment; #PF(fault-code) for a page fault

#### Real Address

Interrupt 13 if any part of the operand would lie outside the effective address space from 0 to 0FFFFH

#### Virtual 8086

Same as Real Address Mode; #PF(fault-code) for a page fault

**CALL** Call Procedure

| Opcode       | Instruction          | Clocks                                 | Description                                          |
|--------------|----------------------|----------------------------------------|------------------------------------------------------|
| E8 <i>cw</i> | CALL <i>rel16</i>    | 7+ <i>m</i>                            | Call near, displacement relative to next instruction |
| FF /2        | CALL <i>r/m16</i>    | 7+ <i>m</i> /10+ <i>m</i>              | Call near, register indirect/memory indirect         |
| 9A <i>cd</i> | CALL <i>ptr16:16</i> | 17+ <i>m</i> , <i>pm</i> =34+ <i>m</i> | Call intersegment to full pointer given              |
| 9A <i>cd</i> | CALL <i>ptr16:16</i> | <i>pm</i> =52+ <i>m</i>                | Call gate, same privilege                            |
| 9A <i>cd</i> | CALL <i>ptr16:16</i> | <i>pm</i> =86+ <i>m</i>                | Call gate, more privilege, no parameters             |
| 9A <i>cd</i> | CALL <i>ptr16:16</i> | <i>pm</i> =94+4 <i>x</i> + <i>m</i>    | Call gate, more privilege, <i>x</i> parameters       |
| 9A <i>cd</i> | CALL <i>ptr16:16</i> | <i>pm</i> =217-309 <sup>†</sup>        | Call to task                                         |
| FF /3        | CALL <i>m16:16</i>   | 22+ <i>m</i> , <i>pm</i> =38+ <i>m</i> | Call intersegment, address at <i>r/m</i> dword       |
| FF /3        | CALL <i>m16:16</i>   | <i>pm</i> =56+ <i>m</i>                | Call gate, same privilege                            |
| FF /3        | CALL <i>m16:16</i>   | <i>pm</i> =90+ <i>m</i>                | Call gate, more privilege, no parameters             |
| FF /3        | CALL <i>m16:16</i>   | <i>pm</i> =98+4 <i>x</i> + <i>m</i>    | Call gate, more privilege, <i>x</i> parameters       |
| FF /3        | CALL <i>m16:16</i>   | <i>pm</i> =222-314 <sup>†</sup>        | Call to task                                         |
| E8 <i>cd</i> | CALL <i>rel32</i>    | 7+ <i>m</i>                            | Call near, displacement relative to next instruction |
| FF /2        | CALL <i>r/m32</i>    | 7+ <i>m</i> /10+ <i>m</i>              | Call near, indirect                                  |
| 9A <i>cp</i> | CALL <i>ptr16:32</i> | 17+ <i>m</i> , <i>pm</i> =34+ <i>m</i> | Call intersegment, to full pointer given             |
| 9A <i>cp</i> | CALL <i>ptr16:32</i> | <i>pm</i> =52+ <i>m</i>                | Call gate, same privilege                            |
| 9A <i>cp</i> | CALL <i>ptr16:32</i> | <i>pm</i> =86+ <i>m</i>                | Call gate, more privilege, no parameters             |
| 9A <i>cp</i> | CALL <i>ptr32:32</i> | <i>pm</i> =94+4 <i>x</i> + <i>m</i>    | Call gate, more privilege, <i>x</i> parameters       |
| 9A <i>cp</i> | CALL <i>ptr16:32</i> | <i>pm</i> =217-309 <sup>†</sup>        | Call to task                                         |

## CALL

---

|       |                    |                      |                                                |
|-------|--------------------|----------------------|------------------------------------------------|
| FF /3 | CALL <i>m16:32</i> | $22+m, pm=38+m$      | Call intersegment, address at <i>r/m</i> dword |
| FF /3 | CALL <i>m16:32</i> | $pm=56+m$            | Call gate, same privilege                      |
| FF /3 | CALL <i>m16:32</i> | $pm=90+m$            | Call gate, more privilege, no parameters       |
| FF /3 | CALL <i>m16:32</i> | $pm=98+4x+m$         | Call gate, more privilege, x parameters        |
| FF /3 | CALL <i>m16:32</i> | $pm=222-314^\dagger$ | Call to task                                   |

<sup>†</sup> See also: 80386 Programmer's Reference Manual

### Operation

```
IF destination address > its segment limit THEN #GP(0);
IF rel16 or rel32 type call THEN (*near relative call*)
    IF OperandSize = 16 THEN
        Push(IP);
        EIP := (EIP + rel16) AND 0000FFFFH;
    ELSE (*OperandSize = 32*)
        Push(EIP);
        EIP := EIP + rel32;
ENNDIF; (*rel16 or rel32 type call*)
IF r/m16 or r/m32 type call THEN (*near absolute call*)
    IF OperandSize = 16 THEN
        Push(IP);
        EIP := [r/m16] AND 0000FFFFH;
    ELSE (*OperandSize = 32*)
        Push(EIP);
        EIP := [r/m32];
ENDIF; (*r/m16 or r/m32 type call*)
IF (PE = 0 OR (PE = 1 AND VM = 1) )
(*mode = real address or virtual 8086*)
    AND instruction = FarCall THEN
(*operand is m16:16/32 or ptr16:16/32*)
    IF OperandSize = 16 THEN
        Push(CS);
        Push(IP); (*next instruction address: 16-bits*)
    ELSE (*OperandSize = 32*)
        Push(CS);
        Push(EIP);
```

```

IF operand is m16:16 or m16:32 THEN (*indirect far call*)
  IF OperandSize = 16 THEN
    CS:IP := [m16:16];
    EIP := EIP AND 0000FFFFH; (*clear upper bits*)
  ELSE
    CS:EIP := ptr16:32;
  ENDF; (*ptr16:16 or ptr16:32 type call*)
ENDIF; (*mode = real address or virtual 8086*)
IF (PE = 1 AND VM = 0) (*mode = protected*)
  AND instruction = FarCall THEN
  IF new CS selector is null THEN #GP(0);
  IF new CS selector is NOT within its descriptor table limits
    THEN #GP(new CS selector);
  (*Examine AR of selected descriptor for various
  legal values; depending on value: *)
  GOTO CONFORMING_CODE_SEGMENT;
  GOTO NONCONFORMING_CODE_SEGMENT;
  GOTO CALL_GATE;
  GOTO TASK_GATE;
  GOTO TASK_STATE_SEGMENT;
ELSE #GP(code segment selector); (*AR illegal*)

CONFORMING_CODE_SEGMENT:
  IF DPL > CPL THEN #GP(code segment selector);
  IF segment NOT PRESENT THEN
    #NP (code segment selector);
  Stack must be big enough for return address ELSE
    #SS(0);
  IF target_offset NOT in code segment limit THEN #GP(0);
  Load code segment descriptor into CS cache;
  Load CS with new code segment selector;
  Load EIP with ZeroExtend(new offset);
  IF OperandSize = 16 THEN
    EIP := EIP AND 0000FFFFH;

NONCONFORMING_CODE_SEGMENT:
  IF RPL > CPL THEN #GP(code segment selector);
  IF DPL NOT = CPL then #GP(code segment selector);
  IF segment NOT PRESENT THEN
    #NP(code segment selector);
  Stack must be big enough for return address ELSE #SS(0);
  IF target_offset NOT in code segment limit THEN #GP(0);
  Load code segment descriptor into CS cache;

```

```
Load CS with new code segment selector;
Set RPL of CS to CPL;
Load EIP with ZeroExtend(new offset);
IF OperandSize = 16 THEN
    EIP := EIP AND 0000FFFFH;
```

**CALL\_GATE:**

```
IF call gate DPL < CPL THEN #GP(call gate selector);
IF call gate DPL < RPL THEN #GP(call gate selector);
IF call gate NOT PRESENT THEN #NP(call gate selector);
(*Examine code segment selector in call gate descriptor: *)
IF selector is null THEN #GP(0);
IF selector is NOT within its descriptor table limits THEN
    #GP (code segment selector);
IF AR of selected descriptor indicates non-code segment THEN
    #GP(code segment selector);
IF DPL of selected descriptor > CPL THEN
    #GP(code segment selector);
IF non-conforming code segment AND DPL < CPL THEN
    GOTO MORE_PRIVILEGE;
ELSE
    GOTO SAME_PRIVILEGE;
```

**MORE\_PRIVILEGE:**

```
Get new SS selector for new privilege level from TSS;
(*Check selector and descriptor for new SS: *)
IF selector is null THEN #TS(0);
IF selector index NOT within descriptor table limits THEN
    #TS(SS selector);
IF selector's RPL NOT = DPL of code segment THEN
    #TS(SS selector);
IF stack segment DPL NOT = DPL of code segment THEN
    #TS(SS selector);
Descriptor must indicate writable data segment ELSE
    #TS(SS selector);
IF segment NOT PRESENT THEN #SS(SS selector);
IF OperandSize = 32 THEN
    New stack must have room for parameters plus 16 bytes
    ELSE #SS(0);
IF target_offset NOT in code segment limit THEN #GP(0);
Load new SS:ESP value from TSS;
Load new CS:EIP value from gate;
```

```

ELSE (*OperandSize = 16*)
    New stack must have room for parameters plus 8 bytes
    ELSE #SS(0);
    IF target_offset NOT in code segment limit THEN #GP(0);
    Load new SS:SP from TSS;
    Load new CS:IP value from gate;
ENDIFELSE;
Load CS descriptor;
Load SS descriptor;
Push long pointer of old stack onto new stack;
Get word count from call gate, mask to 5-bits;
Copy parameters from old stack onto new stack;
Push return address onto new stack;
Set CPL to stack segment DPL;
Set RPL of CS to CPL;
(*END CALL_GATE to MORE_PRIVILEGE*)

SAME_PRIVILEGE:
IF OperandSize = 32 THEN
    Stack must have room for 6-byte return address
    (*padded to 8 bytes*) ELSE #SS(0);
    IF target_offset NOT in code segment limit THEN #GP(0);
    Load CS:EIP from gate;
ELSE (*OperandSize = 16*)
    Stack must have room for 4-byte return address
    ELSE #SS(0);
    IF target_offset NOT in code segment limit THEN #GP(0);
    Load CS:IP from gate;
ENDIFELSE;
Push return address onto stack;
Load code segment descriptor into CS cache;
Set RPL of CS to CPL;
(*END CALL_GATE*)

TASK_GATE:
IF task gate DPL < CPL THEN #TS(gate selector);
IF task gate DPL < RPL THEN #TS(gate selector);
IF task gate NOT PRESENT THEN #NP(gate selector);
(*Examine selector to TSS, given in task gate descriptor: *)
    Must specify global in local/global bit ELSE #TS(TSS selector);
    Index must be within GDT limits ELSE #TS(TSS selector);
(*END checks selector in task gate descriptor*)

```

```
IF new TSS stack selector(s) THEN
(*Check new TSS privileged stack selectors: *)
  IF stack selector NOT PRESENT THEN #SS(bad stack selector);
  IF stack selector invalid THEN #TS(bad stack selector);
(*END checks new TSS stack selector(s)*)
SwitchTasks (*with nesting*) to TSS;
IF (E)IP NOT in code segment limit THEN #TS(0);

TASK_STATE_SEGMENT:
  IF TSS DPL < CPL THEN #TS(TSS selector);
  IF TSS DPL < RPL THEN #TS(TSS selector);
  SwitchTasks (*with nesting*) to TSS;
  IF (E)IP NOT in code segment limit THEN #TS(0);
```

## Discussion

The `CALL` instruction causes a procedure (designated by the operand) to be executed. After a `RET` instruction is executed within the procedure, the caller's execution resumes at the instruction following the `CALL`.

The assembler automatically generates the correct form of `CALL` according to the procedure operand's type. A procedure name is a label representing the destination of the `CALL`.

Near calls are those with `r/m16`, `r/m32`, `rel16`, or `rel32` operands. Near calls do not need to change or save the segment register (CS) value. The `CALL rel32` and `CALL rel16` forms determine the destination by adding a signed offset to the next instruction's address:

- The `rel32` form is used when the operand size attribute is 32-bits. The result is stored in the 32-bit EIP register.
- The `rel16` form is used when the `CALL`'s operand size attribute is 16-bits. The result is also stored in EIP, but its upper bits are cleared so that the offset value does not exceed 16-bits.

`CALL r/m16` and `CALL r/m32` specify a register or memory location from which the absolute segment offset for the procedure is fetched.

In real address or virtual 8086 mode, the long pointer provides 16-bits for the CS register and 32- or 16-bits for the

Far calls are those with `ptr16:32`, `ptr16:16`, `m16:32`, and `m16:16` operands. `CALL ptr16:32` uses a 6-byte operand as a long pointer to the procedure; `CALL ptr16:16` uses a 4-byte operand. `CALL m16:32` and `CALL m16:16` fetch the long pointer from the specified memory location (indirection).

EIP register (depending on the operand size attribute). These forms of `CALL` push both CS and EIP or IP as a return address.

In protected mode, `CALL ptr16:32` and `CALL ptr16:16` consult the access rights (AR) in the descriptor indexed by the selector part of the long pointer. Depending on the value of AR, `CALL` will perform one of the following control transfers:

- A far call to the same protection level
- An inter-protection level far call
- A task switch

Any far call from a 32-bit code segment to a 16-bit code segment should be made from the first 64K bytes of the 32-bit code segment. `CALL`'s operand size attribute is set to 16, so it can save only 16-bits as a return address offset.

## Flags Affected

All flags are affected if a task switch occurs; otherwise, no flags are affected

## Exceptions by Mode

### Protected

For near indirect calls: #GP(0) for an illegal memory operand effective address in the CS, DS, ES, FS, or GS segments; #SS(0) if pushing the return address exceeds the bounds of the stack segment; #GP(0) if the indirect offset obtained is beyond the code segment limits; #PF(fault-code) for a page fault

For near direct calls: #GP(0) if procedure location is beyond the code segment limits; #SS(0) if pushing the return address exceeds the bounds of the stack segment; #PF(fault-code) for a page fault

For far calls: #GP, #NP, #SS, and #TS, as indicated in the Operation section

### Real Address

Interrupt 13 if any part of the operand would be outside the effective address space from 0 to 0FFFFH

### Virtual 8086

Same as Real Address Mode; #PF(fault code) for a page fault

### CBW/CWDE Convert Byte to Word/Convert Word to Dword

| Opcode | Instruction | Clocks | Description              |
|--------|-------------|--------|--------------------------|
| 98     | CBW         | 3      | AX := sign-extend of AL  |
| 98     | CWDE        | 3      | EAX := sign-extend of AX |

### Operation

```
IF OperandSize = 16 (*instruction = CBW*) THEN
    AX := SignExtend(AL);
ELSE (*OperandSize = 32, instruction = CWDE*)
    EAX := SignExtend(AX);
```

### Discussion

CBW converts the signed byte in AL to a signed word in AX by extending the most significant bit of AL (the sign bit) into all of the bits of AH. CWDE converts the signed word in AX to a dword in EAX. Note that CWDE is not a variant of CWD. CWD uses DX:AX, rather than EAX, as a destination.

### Flags Affected

None

### Exceptions by Mode

#### Protected

None

#### Real Address

None

#### Virtual 8086

None

**CLC** Clear Carry Flag

| Opcode | Instruction | Clocks | Description      |
|--------|-------------|--------|------------------|
| F8     | CLC         | 2      | Clear carry flag |

**Operation**

```
CF := 0;
```

**Discussion**

CLC clears the carry flag. It does not affect other flags or registers.

**Flags Affected**

```
CF = 0
```

**Exceptions by Mode****Protected**

None

**Real Address**

None

**Virtual 8086**

None

**CLD** Clear Direction Flag

| Opcode | Instruction | Clocks | Description          |
|--------|-------------|--------|----------------------|
| FC     | CLD         | 2      | Clear direction flag |

**Operation**

DF := 0;

**Discussion**

CLD clears the direction flag. After CLD executes, string operations will increment the index registers (E)SI and/or (E)DI. CLD does not affect other flags or registers.

**Flags Affected**

DF = 0

**Exceptions by Mode****Protected**

None

**Real Address**

None

**Virtual 8086**

None

**CLI** Clear Interrupt Flag

| Opcode | Instruction | Clocks | Description                               |
|--------|-------------|--------|-------------------------------------------|
| FA     | CLI         | 3      | Clear interrupt flag; interrupts disabled |

**Operation**

```
IF CPL > IOPL THEN
    #GP(0);
ELSE
    IF (*interrupt flag*) := 0;
```

**Discussion**

CLI clears the interrupt flag if the current privilege level is at least as privileged as IOPL. (IOPL specifies the least privileged level at which I/O can be performed.)

After CLI executes, external interrupts are not recognized until the interrupt flag is set. CLI affects no other flags.

**Flags Affected**

IF = 0

**Exceptions by Mode****Protected**

#GP(0) if the current privilege level is greater (has less privilege) than IOPL in the flags register.

**Real Address**

None

**Virtual 8086**

#GP(0) as for Protected Mode

## CLTS Clear Task Switched Flag in CR0

| Opcode | Instruction | Clocks | Description              |
|--------|-------------|--------|--------------------------|
| 0F 06  | CLTS        | 5      | Clear task-switched flag |

### Operation

```
TS (*Flag in CR0*) := 0;
```

### Discussion

CLTS clears the task-switched (TS) flag in the machine status word (MSW) of register CR0. The processor sets this flag every time a task switch occurs.

CLTS appears only in operating system software. It is a privileged instruction that can be executed only at level 0. The TS flag is used to synchronize processor task switching with numeric coprocessor context switching as follows:

- Every execution of an `ESC` instruction is trapped if the TS flag is set.
- Every execution of an `(F)WAIT` instruction is trapped if both the TS and MP flags are set.

These cases generate Interrupt 7. If a task switch occurs after an `ESC` (numeric) instruction begins executing, the numeric coprocessor context may need to be saved before a new `ESC` instruction can be issued. A fault handler should save the current context, restore the new task context, and reset the TS flag.

### Flags Affected

TS = 0 (TS in CR0, not the `(E)FLAGS` register)

### Exceptions by Mode

#### Protected

#GP(0) if CLTS is executed with a current privilege level other than 0

#### Real Address

None (valid in Real Address Mode to allow initialization for Protected Mode)

#### Virtual 8086

#GP(0)

**CMC** Complement Carry Flag

| Opcode | Instruction | Clocks | Description           |
|--------|-------------|--------|-----------------------|
| F5     | CMC         | 2      | Complement carry flag |

**Operation**

```
CF := NOT CF;
```

**Discussion**

CMC changes the carry flag value from 0 to 1 or from 1 to 0. It does not affect any other flags.

**Flags Affected**

CF as described

**Exceptions by Mode****Protected**

None

**Real Address**

None

**Virtual 8086**

None

## CMP Compare Two Operands

| Opcode          | Instruction                     | Clocks | Description                                              |
|-----------------|---------------------------------|--------|----------------------------------------------------------|
| 3C <i>ib</i>    | CMP AL, <i>imm8</i>             | 2      | Compare immediate byte to AL                             |
| 3D <i>iw</i>    | CMP AX, <i>imm16</i>            | 2      | Compare immediate word to AX                             |
| 3D <i>id</i>    | CMP EAX, <i>imm32</i>           | 2      | Compare immediate dword to EAX                           |
| 80 /7 <i>ib</i> | CMP <i>r/m8</i> , <i>imm8</i>   | 2/5    | Compare immediate byte to <i>r/m</i> byte                |
| 81 /7 <i>iw</i> | CMP <i>r/m16</i> , <i>imm16</i> | 2/5    | Compare immediate word to <i>r/m</i> word                |
| 81 /7 <i>id</i> | CMP <i>r/m32</i> , <i>imm32</i> | 2/5    | Compare immediate dword to <i>r/m</i> dword              |
| 83 /7 <i>ib</i> | CMP <i>r/m16</i> , <i>imm8</i>  | 2/5    | Compare sign extended immediate byte to <i>r/m</i> word  |
| 83 /7 <i>ib</i> | CMP <i>r/m32</i> , <i>imm8</i>  | 2/5    | Compare sign extended immediate byte to <i>r/m</i> dword |
| 38 / <i>r</i>   | CMP <i>r/m8</i> , <i>r8</i>     | 2/5    | Compare byte register to <i>r/m</i> byte                 |
| 39 / <i>r</i>   | CMP <i>r/m16</i> , <i>r16</i>   | 2/5    | Compare word register to <i>r/m</i> word                 |
| 39 / <i>r</i>   | CMP <i>r/m32</i> , <i>r32</i>   | 2/5    | Compare dword register to <i>r/m</i> dword               |
| 3A / <i>r</i>   | CMP <i>r8</i> , <i>r/m8</i>     | 2/6    | Compare <i>r/m</i> byte to byte register                 |
| 3B / <i>r</i>   | CMP <i>r16</i> , <i>r/m16</i>   | 2/6    | Compare <i>r/m</i> word to word register                 |
| 3B / <i>r</i>   | CMP <i>r32</i> , <i>r/m32</i>   | 2/6    | Compare <i>r/m</i> dword to dword register               |

## Operation

```
(*CMP's purpose is to set the flags*)
IF (RightSrc is byte) AND (LeftSrc is word or dword) THEN
    LeftSrc - SignExtend(RightSrc);
ELSE
    LeftSrc - RightSrc;
```

---

## Discussion

CMP subtracts the second operand from the first and sets the flags accordingly. If an operand greater than one byte is compared to an immediate byte, the byte value is first sign-extended. CMP does not store the result of its non-destructive subtraction. CMP is used in conjunction with conditional jumps and the SETcc instructions. (See the Jcc instructions for a list of signed and unsigned flag tests provided.)

## Flags Affected

OF, SF, ZF, AF, PF, and CF as described in Appendix A

## Exceptions by Mode

### Protected

#GP(0) for an illegal memory operand effective address in the CS, DS, ES, FS, or GS segments; #SS(0) for an illegal address in the SS segment; #PF(fault-code) for a page fault

### Real Address

Interrupt 13 if any part of the operand would lie outside the effective address space from 0 to 0FFFFH

### Virtual 8086

Same as Real Address Mode; #PF(fault-code) for a page fault

## CMPS/CMPSB/CMPSW/CMPSD Compare String Operands

| Opcode | Instruction         | Clocks | Description                                                               |
|--------|---------------------|--------|---------------------------------------------------------------------------|
| A6     | CMPS <i>m8,m8</i>   | 10     | Compare bytes ES:[ (E)DI] (second operand) with [ (E)SI] (first operand)  |
| A7     | CMPS <i>m16,m16</i> | 10     | Compare words ES:[ (E)DI] (second operand) with [ (E)SI] (first operand)  |
| A7     | CMPS <i>m32,m32</i> | 10     | Compare dwords ES:[ (E)DI] (second operand) with [ (E)SI] (first operand) |
| A6     | CMPSB               | 10     | Compare bytes ES:[ (E)DI] with DS: [ (E)SI]                               |
| A7     | CMPSW               | 10     | Compare words ES:[ (E)DI] with DS: [ (E)SI]                               |
| A7     | CMPSD               | 10     | Compare dwords ES:[ (E)DI] with DS:[ (E)SI]                               |

### Operation

```

IF (instruction = CMPSD) OR (instruction has dword operands)
THEN
    OperandSize = 32; (*Assembler action*)
ELSE
    OperandSize = 16;
    IF AddressSize = 16 THEN
        Use SI for SrcIndex and DI for DestIndex;
    ELSE (*AddressSize = 32*)
        Use ESI for SrcIndex and EDI for DestIndex;
    IF byte type instruction THEN
        [SrcIndex] - [DestIndex]; (*low-byte comparison in words*)
        IF DF = 0 THEN IncDec := 1 ELSE IncDec := -1;
    ELSE
        [SrcIndex] - [DestIndex]; (*comparison*)
        IF OperandSize = 16 THEN
            IF DF = 0 THEN IncDec := 2 ELSE IncDec := -2;
        ELSE (*OperandSize = 32*)
            IF DF = 0 THEN IncDec := 4 ELSE IncDec := -4;
        SrcIndex := SrcIndex + IncDec;
        DestIndex := DestIndex + IncDec;
    
```

## Discussion

CMPS compares the byte, word, or dword pointed to by the source index register with the byte, word, or dword pointed to by the destination index register. CMPS does the comparison by subtracting the destination operand from the source operand. CMPS does not store the result of its subtraction; it sets the flags.

If the address size attribute of this instruction is 16-bits, CMPS uses SI and DI for source and destination index registers; otherwise, it uses ESI and EDI. Load the correct index values into the appropriate registers before executing CMPS. The (E)SI and (E)DI contents determine addresses for compared memory values.

The direction of subtraction for CMPS is [SI] - [DI] or [ESI] - [EDI]. The left operand ( (E)SI) is the source, and the right operand ( (E)DI) is the destination. CMPS reverses ASM386's conventional operand ordering: left-to-right is usually destination-source.

The CMPS operands determine whether bytes, words, or dwords are compared. The segment addressability of the first operand (SI or ESI) determines whether a segment override byte is produced or whether the default segment register DS is used. The second operand (DI or EDI) must be addressable from the ES register; no segment override is possible.

After the comparison, both the source index and destination index registers are automatically advanced. If the direction flag is 0 (CLD was executed), the registers increment; if the direction flag is 1 (STD was executed), the registers decrement. The registers increment or decrement by 1 if a byte is compared, by 2 if a word is compared, or by 4 if a dword is compared.

CMPSB, CMPSW, and CMPSD are synonyms for the byte, word, and dword CMPS instructions. They are simpler, but they do not provide type checking, nor do they allow the (E)SI operand to override the DS segment.

CMPS can be preceded by the REPE or REPNE prefix for block comparison of (E)CX bytes, words, or dwords. See the REP reference page for details about this operation.

## Flags Affected

OF, SF, ZF, AF, PF, and CF as described in Appendix A

### Exceptions by Mode

#### Protected

#GP(0) for an illegal memory operand effective address in the CS, DS, ES, FS, or GS segments; #SS(0) for an illegal address in the SS segment; #PF(fault-code) for a page fault

#### Real Address

Interrupt 13 if any part of the operand would lie outside the effective address space from 0 to 0FFFFH

#### Virtual 8086

Same as Real Address Mode; #PF(fault-code) for a page fault

## CMPXCHG Compare Exchange (not available on Intel386 or 376 processors)

| Opcode   | Instruction               | Clocks | Description                                                                                                        |
|----------|---------------------------|--------|--------------------------------------------------------------------------------------------------------------------|
| 0F A6 /r | CMPXCHG <i>r/m8, r8</i>   | —      | Compare AL with <i>r/m8</i> ; if equal, move <i>r8</i> to <i>r/m8</i> ; if not equal, move <i>r/m8</i> to AL       |
| 0F A7 /r | CMPXCHG <i>r/m16, r16</i> | —      | Compare AX with <i>r/m16</i> ; if equal, move <i>r16</i> to <i>r/m16</i> ; if not equal, move <i>r/m16</i> to AX   |
| 0F A7 /r | CMPXCHG <i>r/m32, r32</i> | —      | Compare EAX with <i>r/m32</i> ; if equal, move <i>r32</i> to <i>r/m32</i> ; if not equal, move <i>r/m32</i> to EAX |

### Operation

```

IF OperandSize = 8 (*r/m8, r8, AL*) THEN
    temp := r/m8;
    IF AL = temp THEN
        r/m8 := r8;
    ELSE
        r/m8 := temp;
        AL := temp;
IF OperandSize = 16 (*r/m16, r16, AX*) THEN
    temp := r/m16;
    IF AX = temp THEN
        r/m16 := r16;
    ELSE
        r/m16 := temp;
        AX := temp;
IF OperandSize = 32 (*r/m32, r32, EAX*) THEN
    temp := r/m32;
    IF EAX = temp THEN
        r/m32 := r32;
    ELSE
        r/m32 := temp;
        EAX := temp;

```

### Discussion

CMPXCHG compares the contents of AL, AX, or EAX with the contents of the first operand and sets the flags accordingly. If the comparison is equal, the second operand is copied into the first; if the comparison is not equal, the first operand is copied into AL, AX, or EAX.

The LOCK prefix is only valid for the forms of CMPXCHG which involve memory operands.

### Flags Affected

OF, SF, ZF, AF, PF, and CF as described in Appendix A

### Exceptions by Mode

#### Protected

#GP(0) if the result is in a nonwritable segment; #GP(0) for an illegal memory operand effective address in the CS, DS, ES, FS, or GS segments; #SS(0) for an illegal address in the SS segment; #PF(fault-code) for a page fault

#### Real Address

Interrupt 13 if any part of the operand would lie outside the effective address space from 0 to 0FFFFH

#### Virtual 8086

Same as Real Address Mode; #PF(fault-code) for a page fault

**CWD/CDQ** Convert Word to Dword/Convert Dword to Qword

| Opcode | Instruction | Clocks | Description                   |
|--------|-------------|--------|-------------------------------|
| 99     | CWD         | 2      | DX:AX := sign-extend of AX    |
| 99     | CDQ         | 2      | EDX:EAX := sign-extend of EAX |

**Operation**

```

IF Operand Size = 16 (*CWD instruction*) THEN
  IF AX < 0 THEN
    DX := 0FFFFH;
  ELSE
    DX := 0;
  ELSE (*OperandSize = 32, CDQ instruction*)
    IF EAX < 0 THEN
      EDX := 0FFFFFFFFH;
    ELSE
      EDX := 0;

```

**Discussion**

CWD converts the signed word in AX to a signed dword in DX:AX by extending the most significant bit of AX into all the bits of DX. CDQ converts the signed dword in EAX to a signed qword in the register pair EDX:EAX by extending the most significant bit of EAX (the sign bit) into all the bits of EDX.

Note that CWDE is not a variant of CWD. CWDE uses EAX as a destination, rather than (E)DX:(E)AX.

**Flags Affected**

None

**Exceptions by Mode****Protected**

None

**Real Address**

None

**Virtual 8086**

None

**DAA** Decimal Adjust AL after Addition

| Opcode | Instruction | Clocks | Description                      |
|--------|-------------|--------|----------------------------------|
| 27     | DAA         | 4      | Decimal adjust AL after addition |

**Operation**

```

IF ( (AL AND 0FH) > 9) OR (AF = 1) THEN
    AL := AL + 6;
    AF := 1;
ELSE
    AF := 0;
IF (AL > 9FH) OR (CF = 1) THEN
    AL := AL + 60H;
    CF := 1;
ELSE
    CF := 0;

```

**Discussion**

Code `DAA` only after an `ADD` instruction that leaves a 2-BCD-digit byte result in the AL register. The `ADD` operands should consist of 2 packed BCD digits. The `DAA` instruction adjusts AL to contain the correct 2-digit packed decimal result.

**Flags Affected**

AF and CF as described in the Operation section; SF, ZF, and PF, as described in Appendix A

**Exceptions by Mode****Protected**

None

**Real Address**

None

**Virtual 8086**

None

## DAS Decimal Adjust AL after Subtraction

| Opcode | Instruction | Clocks | Description                         |
|--------|-------------|--------|-------------------------------------|
| 2F     | DAS         | 4      | Decimal adjust AL after subtraction |

### Operation

```
IF (AL AND 0FH) > 9 OR AF = 1 THEN
AL := AL - 6;
AF := 1;
ELSE
AF := 0;
IF (AL > 9FH) OR (CF = 1) THEN
AL := AL - 60H;
CF := 1;
ELSE
CF := 0;
```

### Discussion

Code `DAS` only after a subtraction instruction that leaves a 2-BCD-digit byte result in the AL register. The operands should consist of 2 packed BCD digits. `DAS` adjusts AL to contain the correct 2-digit packed decimal result.

### Flags Affected

AF and CF as described in the Operation section; SF, ZF, and PF as described in Appendix A

### Exceptions by Mode

#### Protected

None

#### Real Address

None

#### Virtual 8086

None

**DEC** Decrement by 1

| Opcode        | Instruction      | Clocks | Description                     |
|---------------|------------------|--------|---------------------------------|
| FE /1         | DEC <i>r/m8</i>  | 2/6    | Decrement <i>r/m</i> byte by 1  |
| FF /1         | DEC <i>r/m16</i> | 2/6    | Decrement <i>r/m</i> word by 1  |
| FF /1         | DEC <i>r/m32</i> | 2/6    | Decrement <i>r/m</i> dword by 1 |
| 48+ <i>rw</i> | DEC <i>r16</i>   | 2      | Decrement word register by 1    |
| 48+ <i>rd</i> | DEC <i>r32</i>   | 2      | Decrement dword register by 1   |

**Operation**

```
Dest := Dest - 1;
```

**Discussion**

DEC subtracts 1 from the operand. DEC does not change the carry flag. (Use the SUB instruction with an immediate operand of 1 to affect the carry flag.)

**Flags Affected**

OF, SF, ZF, AF, and PF as described in Appendix A

**Exceptions by Mode****Protected**

#GP(0) if the result is a nonwritable segment; #GP(0) for an illegal memory operand effective address in the CS, DS, ES, FS, or GS segments; #SS(0) for an illegal address in the SS segment; #PF(fault-code) for a page fault

**Real Address**

Interrupt 13 if any part of the operand would lie outside the effective address space from 0 to 0FFFFH

**Virtual 8086**

Same as Real Address Mode; #PF(fault-code) for a page fault

## DIV Unsigned Divide

| Opcode | Instruction      | Clocks | Description                                                        |
|--------|------------------|--------|--------------------------------------------------------------------|
| F6 /6  | DIV <i>r/m8</i>  | 14/17  | Unsigned divide AX by <i>r/m</i> byte (AL = Quo, AH = Rem)         |
| F7 /6  | DIV <i>r/m16</i> | 22/25  | Unsigned divide DX:AX by <i>r/m</i> word (AX = Quo, DX = Rem)      |
| F7 /6  | DIV <i>r/m32</i> | 38/41  | Unsigned divide EDX:EAX by <i>r/m</i> dword (EAX = Quo, EDX = Rem) |

## Operation

(\*Divisions are unsigned. The only operand is the divisor; the dividend, quotient, and remainder use implicit registers.\*)

```
IF r/m = 0 THEN
    Interrupt 0;
temp := dividend / (r/m);
IF temp does not fit in quotient THEN
    Interrupt 0;
ELSE
    quotient := temp;
    remainder := dividend MOD (r/m);
```

## Discussion

DIV performs an unsigned division. The dividend is implicit; DIV's single operand is the divisor. The remainder is always less than the divisor.

The divisor, dividend, quotient, and remainder locations are summarized as follows:

**Table 6-17. Operands and Implicit Destinations for DIV**

| Size  | Divisor      | Dividend | Quotient | Remainder |
|-------|--------------|----------|----------|-----------|
| byte  | <i>r/m8</i>  | AX       | AL       | AH        |
| word  | <i>r/m16</i> | DX:AX    | AX       | DX        |
| dword | <i>r/m32</i> | EDX:EAX  | EAX      | EDX       |

## Flags Affected

OF, SF, ZF, AR, PF, and CF are undefined

## Exceptions by Mode

### Protected

Interrupt 0 if the quotient is too large to fit in the destination register (AL or AX), or if the divisor is 0; #GP(0) for an illegal memory operand effective address in the CS, DS, ES, FS, or GS segments; #SS(0) for an illegal address in the SS segment; #PF(fault-code) for a page fault

### Real Address

Interrupt 0 if the quotient is too large to fit in the destination register (AL or AX), or if the divisor is 0; Interrupt 13 if any part of the operand would lie outside the effective address space from 0 to 0FFFFH

### Virtual 8086

Same as Real Address Mode; #PF(fault-code) for a page fault

## ENTER Make Stack Frame for Procedure Parameters

| Opcode          | Instruction                         | Clocks             | Description                           |
|-----------------|-------------------------------------|--------------------|---------------------------------------|
| C8 <i>iw</i> 00 | ENTER <i>imm16</i> ,0               | 10                 | Make procedure stack frame            |
| C8 <i>iw</i> 01 | ENTER <i>imm16</i> ,1               | 12                 | Make stack frame for nested procedure |
| C8 <i>iw ib</i> | ENTER <i>imm16</i> ,<br><i>imm8</i> | 15+4( <i>n</i> -1) | Make stack frame for nested procedure |

## Operation

```
level := level MOD 32; (*level is rightmost parameter*)
IF stack segment is USE = 32 THEN
    StackAddrSize := 32; (*Assembler action*)
    Push(EBP);
    frame_pointer := ESP;
ELSE
    StackAddrSize := 16;
    Push(BP);
    frame_pointer := SP;
IF level > 0 THEN
    FOR i := 1 TO (level - 1) DO
        IF StackAddrSize = 16 THEN
            Push[BP];
            BP := BP - 2;
        ELSE (*StackAddrSize = 32*)
            Push[EBP];
            EBP := EBP - 4;
        ENDFOR;
ENDIF; (*level > 0*)
IF StackAddrSize = 16 THEN
    BP := frame_pointer;
    SP := SP - first_operand;
ELSE
    EBP := frame_pointer;
    ESP := ESP - ZeroExtend(first_operand);
```

---

## Discussion

`ENTER` creates the stack frame required by most block-structured high-level languages. The first operand specifies the number of bytes of dynamic storage allocated on the stack for the routine being entered. The second operand gives the lexical nesting level (0-31) of the routine within the high-level source code. It determines the number of stack frame pointers copied into the new stack frame from the preceding frame.

If the stack size attribute is 16-bits, the processor uses BP as the frame pointer and SP as the stack pointer. If the stack size attribute is 32-bits, the processor uses EBP for the frame pointer and ESP for the stack pointer.

`ENTER` pushes the frame pointer (BP or EBP). `ENTER` copies the frame pointer addresses for enclosing callers' frames, if any; it then sets the frame pointer to the current stack pointer value and subtracts the first operand from the stack pointer.

For example, a procedure with 12 bytes of local variables would have an `ENTER 12,0` instruction at its entry point and a `LEAVE` instruction before every `RET`. The 12 local bytes would be addressed as negative offsets from (E)BP.

## Flags Affected

None

## Exceptions by Mode

### Protected

#SS(0) if SP or ESP would exceed the stack limit at any point during instruction execution; #PF(fault-code) for a page fault

### Real Address

None

### Virtual 8086

None

# HLT

---

## HLT Halt

| Opcode | Instruction | Clocks | Description |
|--------|-------------|--------|-------------|
| F4     | HLT         | 5      | Halt        |

## Operation

Enter Halt state;

## Discussion

HLT stops instruction execution and places the processor in a Halt state. An enabled interrupt, NMI, or a hardware RESET# will resume execution. If an interrupt or NMI is used to resume execution after HLT, the saved CS:IP (or CS:EIP) value points to the instruction following HLT.

## Flags Affected

None

## Exceptions by Mode

### Protected

HLT is a privileged instruction: #GP(0) if the current privilege level is not 0

### Real Address

None

### Virtual 8086

Same as Protected Mode

## IDIV Signed Divide

| Opcode | Instruction       | Clocks | Description                                                |
|--------|-------------------|--------|------------------------------------------------------------|
| F6 /7  | IDIV <i>r/m8</i>  | 19     | Signed divide AX by <i>r/m</i> byte(AL=Quo,AH=Rem)         |
| F7 /7  | IDIV <i>r/m16</i> | 27     | Signed divide DX:AX by <i>r/m</i> word(AX=Quo,DX=Rem)      |
| F7 /7  | IDIV <i>r/m32</i> | 43     | Signed divide EDX:EAX by <i>r/m</i> dword(EAX=Quo,EDX=Rem) |

## Operation

(\*The only operand is the divisor; the dividend, quotient, and remainder use implicit registers.\*)

```
IF r/m = 0 THEN
    Interrupt 0;
ELSE
    temp := dividend / (r/m);
    IF temp does not fit in quotient register THEN
        Interrupt 0;
    ELSE
        quotient := temp;
        remainder := dividend MOD (r/m);
```

## Discussion

IDIV performs a signed division. The dividend, quotient, and remainder are implicitly allocated to fixed registers. Only the divisor is given as an explicit *r/m* operand. The type of the divisor (size) determines which instructions and registers to use as follows:

**Table 6-18. Operands and Implicit Destinations for IDIV**

| Size  | Divisor      | Dividend | Quotient | Remainder |
|-------|--------------|----------|----------|-----------|
| byte  | <i>r/m8</i>  | AX       | AL       | AH        |
| word  | <i>r/m16</i> | DX:AX    | AX       | DX        |
| dword | <i>r/m32</i> | EDX:EAX  | EAX      | EDX       |

If the resulting quotient is too large to fit in the destination, or if the divisor is 0, an Interrupt 0 is generated. Nonintegral quotients are truncated toward 0. The remainder has the same sign as the dividend, and its absolute value is always less than the divisor's.

### Flags Affected

For dword operands, CF and OF are set (1) if EDX is not the sign extension of EAX; otherwise, CF = 0 and OF = 0; SF, ZF, AF, and PF are undefined

### Exceptions by Mode

#### Protected

Interrupt 0 if the quotient is too large to fit in the implicit destination register, or if the divisor is 0; #GP (0) for an illegal memory operand effective address in the CS, DS, ES, FS, or GS segments; #SS(0) for an illegal address in the SS segment; #PF(fault-code) for a page fault

#### Real Address

Interrupt 0 if the quotient is too large to fit in the implicit destination register, or if the divisor is 0; Interrupt 13 if any part of the operand would lie outside the address space from 0 to 0FFFFH

#### Virtual 8086

Same as Real Address Mode; #PF(fault-code) for a page fault

**IMUL** Signed Multiply

| Opcode          | Instruction                 | Clocks     | Description                                                     |
|-----------------|-----------------------------|------------|-----------------------------------------------------------------|
| F6 /5           | IMUL <i>r/m8</i>            | 9-14/12-17 | AX:=AL * <i>r/m</i> byte                                        |
| F7 /5           | IMUL <i>r/m16</i>           | 9-22/12-25 | DX:AX := AL * <i>r/m</i> word                                   |
| F7 /5           | IMUL <i>r/m32</i>           | 9-38/12-41 | EDX:EAX := EAX * <i>r/m</i> dword                               |
| 0F AF /r        | IMUL <i>r16,r/m16</i>       | 9-22/12-25 | word register := word register * <i>r/m</i> word                |
| 0F AF /r        | IMUL <i>r32,r/m32</i>       | 9-38/12-41 | dword register := dword register * <i>r/m</i> dword             |
| 6B /r <i>ib</i> | IMUL <i>r16,r/m16,imm8</i>  | 9-14/12-17 | word register := <i>r/m16</i> * sign-extended immediate byte    |
| 6B /r <i>ib</i> | IMUL <i>r32,r/m32,imm8</i>  | 9-14/12-17 | dword register := <i>r/m32</i> * sign-extended immediate byte   |
| 6B /r <i>ib</i> | IMUL <i>r16,imm8</i>        | 9-14/12-17 | word register := word register * sign-extended immediate byte   |
| 6B /r <i>ib</i> | IMUL <i>r32,imm8</i>        | 9-14/12-17 | dword register := dword register * sign-extended immediate byte |
| 69 /r <i>iw</i> | IMUL <i>r16,r/m16,imm16</i> | 9-22/12-25 | word register := <i>r/m16</i> * immediate word                  |
| 69 /r <i>id</i> | IMUL <i>r32,r/m32,imm32</i> | 9-38/12-41 | dword register := <i>r/m32</i> * immediate dword                |
| 69 /r <i>iw</i> | IMUL <i>r16,imm16</i>       | 9-22/12-25 | word register := <i>r/m16</i> * immediate word                  |
| 69 /r <i>id</i> | IMUL <i>r32,imm32</i>       | 9-38/12-41 | dword register := <i>r/m32</i> * immediate dword                |

⇒ **Note**

The processor uses an early-out multiply algorithm. The actual number of clocks depends on the position of the most significant bit in the optimizing multiplier, shown underlined in the table. The optimization occurs for positive and negative values. Because of the early-out algorithm, clock counts given are minimum to maximum. To calculate the actual clocks, use the following formula:

```
IF  $m = 0$  THEN ActualClock := 9;
ELSE ActualClock := max( ceiling( log2 | $m$ |), 3) + 6 clocks;
```

where  $m$  is the optimizing multiplier. Add 3 clocks if the multiplier is a memory operand.

## Operation

```
result := multiplicand * multiplier;
```

## Discussion

IMUL performs signed multiplication. Some forms of the instruction use implicit register operands. The operand combinations for all forms of the instruction are shown in the Description column of the preceding table.

IMUL clears the overflow and carry flags under the following conditions:

**Table 6-19. When IMUL Clears CF and OF**

| Operand(s)             | Condition for Clearing CF and OF      |
|------------------------|---------------------------------------|
| <i>r/m8</i>            | AX = sign-extend AL to 16-bits        |
| <i>r/m16</i>           | DX:AX = sign-extend AX to 32-bits     |
| <i>r/m32</i>           | EDX:EAX = sign-extend EAX to 64-bits  |
| <i>r16,r/m16</i>       | Result exactly fits within <i>r16</i> |
| <i>r32,r/m32</i>       | Result exactly fits within <i>r32</i> |
| <i>r16,r/m16,imm16</i> | Result exactly fits within <i>r16</i> |
| <i>r32,r/m32,imm32</i> | Result exactly fits within <i>r32</i> |

The IMUL accumulator forms (IMUL *r/m8*, IMUL *r/m16*, or IMUL *r/m32*) yield a result even if the overflow flag is set because such a result is twice the size of the multiplicand and multiplier. This is large enough to handle any possible result.

## Flags Affected

OF and CF as shown in Table 6-19; SF, ZF, AF, and PF are undefined

## Exceptions by Mode

### Protected

#GP(0) for an illegal memory operand effective address in the CS, DS, ES, FS, or GS segments; #SS(0) for an illegal address in the SS segment; #PF(fault-code) for a page fault

### Real Address

Interrupt 13 if any part of the operand would lie outside the effective address space from 0 to 0FFFFH

### Virtual 8086

Same as Real Address Mode; #PF(fault-code) for a page fault

**IN** Input from Port

| Opcode       | Instruction         | Clocks                                         | Description                              |
|--------------|---------------------|------------------------------------------------|------------------------------------------|
| E4 <i>ib</i> | IN AL, <i>imm8</i>  | 12, <i>pm</i> =6 <sup>†</sup> /26 <sup>‡</sup> | Input byte from immediate port into AL   |
| E5 <i>ib</i> | IN AX, <i>imm8</i>  | 12, <i>pm</i> =6 <sup>†</sup> /26 <sup>‡</sup> | Input word from immediate port into AX   |
| E5 <i>ib</i> | IN EAX, <i>imm8</i> | 12, <i>pm</i> =6 <sup>†</sup> /26 <sup>‡</sup> | Input dword from immediate port into EAX |
| EC           | IN AL,DX            | 13, <i>pm</i> =7 <sup>†</sup> /27 <sup>‡</sup> | Input byte from port DX into AL          |
| ED           | IN AX,DX            | 13, <i>pm</i> =7 <sup>†</sup> /27 <sup>‡</sup> | Input word from port DX into AX          |
| ED           | IN EAX,DX           | 13, <i>pm</i> =7 <sup>†</sup> /27 <sup>‡</sup> | Input dword from port DX into EAX        |

† If CPL ≤ IOPL

‡ If CPL > IOPL or if in virtual 8086 mode

**Operation**

```
IF (PE = 1) AND ((VM = 1) OR (CPL > IOPL)) THEN
  (*virtual 8086 mode or protected mode with CPL > IOPL*)
  IF NOT IOPermission(Src, width(Src)) THEN #GP(0);
  Dest := [Src]; (*reads from I/O address space*)
```

**Discussion**

IN transfers a data byte, word, or dword from the port numbered by the second operand into the register (AL, AX, or EAX) specified by the first operand. Access any port from 0 to 65535 by placing the port number in the DX register and using an IN instruction with DX as the second operand. These I/O instructions can be shortened by using an 8-bit number of a port in the instruction.

If executed in virtual 8086 mode or in protected mode with CPL greater than IOPL:

- IN cannot access any given byte unless the I/O permission bit map has a corresponding clear bit.  
See also: I/O permission bit map, Appendix A
- IN also cannot access a dword or word unless it can access every byte in the dword or word.

**Flags Affected**

None

**Exceptions by Mode****Protected**

#GP(0) if the current privilege level is larger (has less privilege) than IOPL and any of the corresponding I/O permission bits in TSS equals 1

**Real Address**

None

**Virtual 8086**

#GP(0) if any of the corresponding I/O permission bits in TSS equals 1

## INC Increment by 1

| Opcode         | Instruction      | Clocks | Description                     |
|----------------|------------------|--------|---------------------------------|
| FE /0          | INC <i>r/m8</i>  | 2/6    | Increment <i>r/m</i> byte by 1  |
| FF /0          | INC <i>r/m16</i> | 2/6    | Increment <i>r/m</i> word by 1  |
| FF /0          | INC <i>r/m32</i> | 2/6    | Increment <i>r/m</i> dword by 1 |
| 40 + <i>rw</i> | INC <i>r16</i>   | 2      | Increment word register by 1    |
| 40 + <i>rd</i> | INC <i>r32</i>   | 2      | Increment dword register by 1   |

## Operation

`Dest := Dest + 1;`

## Discussion

INC adds 1 to the operand. It does not change the carry flag. (Use the ADD instruction with a second operand of 1 to affect the carry flag.)

## Flags Affected

OF, SF, ZF, AF, and PF as described in Appendix A

## Exceptions by Mode

### Protected

#GP(0) if the operand is in a nonwritable segment; #GP(0) for an illegal memory operand effective address in the CS, DS, ES, FS, or GS segments; #SS(0) for an illegal address in the SS segment; #PF(fault-code) for a page fault

### Real Address

Interrupt 13 if any part of the operand would lie outside the address space from 0 to 0FFFFH

### Virtual 8086

Same as Real Address Mode; #PF(fault-code) for a page fault

**INS/INSB/INSW/INSD** Input from Port to String

| Opcode | Instruction        | Clocks                                         | Description                            |
|--------|--------------------|------------------------------------------------|----------------------------------------|
| 6C     | INS <i>m8</i> ,DX  | 15, <i>pm</i> =9 <sup>†</sup> /29 <sup>‡</sup> | Input byte from port DX into ES:(E)DI  |
| 6D     | INS <i>m16</i> ,DX | 15, <i>pm</i> =9 <sup>†</sup> /29 <sup>‡</sup> | Input word from port DX into ES:(E)DI  |
| 6D     | INS <i>m32</i> ,DX | 15, <i>pm</i> =9 <sup>†</sup> /29 <sup>‡</sup> | Input dword from port DX into ES:(E)DI |
| 6C     | INSB               | 15, <i>pm</i> =9 <sup>†</sup> /29 <sup>‡</sup> | Input byte from port DX into ES:(E)DI  |
| 6D     | INSW               | 15, <i>pm</i> =9 <sup>†</sup> /29 <sup>‡</sup> | Input word from port DX into ES:(E)DI  |
| 6D     | INSD               | 15, <i>pm</i> =9 <sup>†</sup> /29 <sup>‡</sup> | Input dword from port DX into ES:(E)DI |

† If CPL ≤ IOPL

‡ If CPL > IOPL or if in virtual 8086 mode

**Operation**

```

IF AddressSize = 16 THEN
    Use DI for DestIndex;
ELSE (*AddressSize = 32*)
    Use EDI for DestIndex;
IF (PE = 1) AND ( (VM = 1) OR (CPL > IOPL) ) THEN
    (*virtual 8086 mode or protected mode with CPL > IOPL*)
    IF NOT IOPermission(Src, width(Src) ) THEN #GP(0);
IF byte type instruction THEN
    ES:[DestIndex] := [DX]; (*reads at DX from I/O address space*)
    IF DF = 0 THEN IncDec := 1 ELSE IncDec := -1;
ELSE (*read word or dword*)
    IF OperandSize = 16 THEN
        ES:[DestIndex] := [DX];
        IF DF = 0 THEN IncDec := 2 ELSE IncDec := -2;
    ELSE (*OperandSize = 32*)
        ES:[DestIndex] := [DX];
        IF DF = 0 THEN IncDec := 4 ELSE IncDec := -4;
DestIndex := DestIndex + IncDec;

```

## Discussion

INS transfers data from the port numbered by the DX register to the memory byte, word, or dword at ES:DestinationIndex. The memory operand must be addressable from ES; no segment override is possible. The destination is DI if the address size attribute of the instruction is 16-bits, or EDI if the address size attribute is 32-bits.

INS does not allow the specification of the port number as an immediate value. The port must be addressed through the DX register. Load the correct value into DX before executing the INS instruction.

The destination address is determined by the contents of the (E)DI register (not by the first operand to INS). The purpose of the operand is to validate ES segment addressability and to determine the data type (byte, word, or dword).

After the transfer, (E)DI advances automatically. If the direction flag is 0 (CLD was executed), (E)DI increments; if the direction flag is 1 (STD was executed), (E)DI decrements. (E)DI increments or decrements by 1 if a byte is input, by 2 if a word is input, or by 4 if a dword is input.

INSB, INSW and INSD are synonyms of the byte, word, and dword INS instructions. They are simpler, but they provide no type or segment checking.

If executed in virtual 8086 mode or in protected mode with CPL greater than IOPL:

- INS cannot access any given byte unless the I/O permission bit map has a corresponding clear bit.  
See also: I/O permission bit map, Appendix A
- INS also cannot access a dword or word unless it can access every byte in the dword or word.

INS can be preceded by the REP prefix for block input of (E)CX bytes or words. See the REP reference page for details of this operation.

## Flags Affected

None

## Exceptions by Mode

### Protected

#GP(0) if CPL is numerically greater than IOPL and any of the corresponding I/O permission bits in TSS equals 1; #GP(0) if the destination is in a nonwritable segment; #GP(0) for an illegal memory operand effective address in the ES segment; #PF(fault-code) for a page fault

**Real Address**

Interrupt 13 if any part of the operand would lie outside the address space from 0 to 0FFFFH

**Virtual 8086**

#GP(0) if any of the corresponding I/O permission bits in TSS equals 1; #GP(0) for an illegal memory operand effective address in the ES segment; #PF(fault-code) for a page fault

**INT/INTO** Transfer Control to Interrupt Procedure

| Opcode       | Instruction     | Clocks                          | Description                                               |
|--------------|-----------------|---------------------------------|-----------------------------------------------------------|
| CC           | INT 3           | 33                              | Interrupt 3 - trap to debugger                            |
| CC           | INT 3           | <i>pm</i> =59                   | Interrupt 3 - protected mode, same privilege              |
| CC           | INT 3           | <i>pm</i> =99                   | Interrupt 3 - protected mode, more privilege              |
| CC           | INT 3           | <i>pm</i> =119                  | Interrupt 3 - from virtual 8086 mode to privilege level 0 |
| CC           | INT 3           | <i>pm</i> =224-314 <sup>†</sup> | Interrupt 3 - protected mode, via task gate               |
| CD <i>ib</i> | INT <i>imm8</i> | 37                              | Interrupt numbered by immediate byte                      |
| CD <i>ib</i> | INT <i>imm8</i> | <i>pm</i> =59                   | Interrupt - protected mode, same privilege                |
| CD <i>ib</i> | INT <i>imm8</i> | <i>pm</i> =99                   | Interrupt - protected mode, more privilege                |
| CD <i>ib</i> | INT <i>imm8</i> | <i>pm</i> =119                  | Interrupt - from virtual 8086 mode to privilege level 0   |
| CD <i>ib</i> | INT <i>imm8</i> | <i>pm</i> =224-314 <sup>†</sup> | Interrupt - protected mode, via task gate                 |
| CE           | INTO            | Fail:3, <i>pm</i> =3<br>Pass:35 | Interrupt 4 - if overflow flag is 1                       |
| CE           | INTO            | <i>pm</i> =59                   | Interrupt 4 - protected mode, same privilege              |
| CE           | INTO            | <i>pm</i> =99                   | Interrupt 4 - protected mode, more privilege              |
| CE           | INTO            | <i>pm</i> =119                  | Interrupt 4 - from virtual 8086 mode to privilege level 0 |
| CE           | INTO            | <i>pm</i> =224-314 <sup>†</sup> | Interrupt 4 - protected mode, via task gate               |

<sup>†</sup> See also: 80386 Programmer's Reference Manual

**Operation**

```
(*These operations also occur for exceptions and external
interrupts*)
IF PE = 0 THEN (*real address mode*)
  IF interrupt table entry > IDT limit THEN #DF(0);
ELSE
  Push(FLAGS);
  IF := 0; (*Clear interrupt flag*)
  TF := 0; (*Clear trap flag*)
  Push(CS);
  Push(IP);
  (*no error codes are pushed*)
```

```

        CS := IDT[interrupt number * 4].selector;
        IP := IDT[interrupt number * 4].offset;
ELSE
    IF VM = 1 THEN
        GOTO INTERRUPT_FROM_VIRTUAL_8086_MODE;
    ELSE
        GOTO PROTECTED_MODE;

PROTECTED_MODE:
    IF interrupt vector NOT within IDT table limit THEN
        #GP(vector number * 8+2+EXT);
    Descriptor AR must indicate interrupt, trap or task gate
    ELSE #GP(vector number * 8+2+EXT);
    IF software interrupt (*caused by INT n, INT 3, INTO,
        BOUND*)
    AND gate descriptor DPL < CPL THEN
        #GP(vector number * 8+2+EXT);
    IF gate NOT PRESENT THEN #NP(vector number * 8+2+EXT);
    IF trap gate OR interrupt gate THEN
        GOTO TRAP_OR_INTERRUPT_GATE;
    ELSE
        GOTO TASK_GATE;

    TRAP_OR_INTERRUPT_GATE:
    (*Examine CS selector and descriptor given in gatedescriptor: *)
    IF selector is null THEN #GP(EXT);
    IF selector NOT within its descriptor table limits THEN
        #GP(selector + EXT);
    IF descriptor AR indicates non-code segment THEN
        #GP(selector + EXT);
        IF segment NOT PRESENT THEN #NP(selector + EXT);
    IF code segment is non-conforming AND DPL < CPL THEN
        GOTO INTERRUPT_TO_MORE_PRIVILEGED;
    IF code segment is conforming OR code segment DPL=CPL
        THEN GOTO INTERRUPT_TO_SAME_PRIVILEGE;
    ELSE #GP(CS selector + EXT);

INTERRUPT_TO_MORE_PRIVILEGED:
    (*Check selector and descriptor for new stack in currentTSS: *)
    IF selector is null THEN #GP(EXT);
    IF selector index NOT within descriptor table limits THEN
        #TS(SS selector + EXT);
    IF selector's RPL NOT = DPL of code segment THEN
        #TS(SS selector + EXT);

```

```
IF stack segment DPL NOT = DPL of code segment THEN
    #TS(SS selector + EXT);
Descriptor must indicate writable data segment
ELSE #TS(SS selector + EXT);
IF segment NOT PRESENT THEN #SS(SSselector +EXT);
IF 32-bit gate THEN
    New stack must have room for 24 bytes ELSE #SS(0);
    IF interrupt caused by exception with error code THEN
        Stack limits must allow pushing 2 more bytes
        ELSE #SS(0);
    gate_offset must be within CS segment boundaries
    ELSE #GP(0);
    Load new SS and ESP values from TSS;
    CS:EIP := selector:offset from gate;
ELSE (*16-bit gate*)
    New stack must have room for 12 bytes ELSE #SS(0);
    IF interrupt caused by exception with error code THEN
        Stack limits must allow pushing 2 more bytes
        ELSE #SS(0);
    gate_offset must be within CS segment boundaries
    ELSE #GP(0);
    Load new SS and SP values from TSS;
    CS:IP := selector:offset from gate;
ENDIFELSE;
Load CS descriptor into CS cache;
Load SS descriptor into SS cache;
IF 32-bit gate THEN
    Push(long pointer to old stack); (*3 words padded to 4*)
    Push(EFLAGS);
    Push(long pointer to return location);
    (*3 words padded to 4*)
ELSE (*16-bit gate*)
    Push(long pointer to old stack); (*2 words*)
    Push(FLAGS);
    Push(long pointer to return location); (*2 words*)
ENDIFELSE;
CPL := (*new code segment's*) DPL;
RPL (*of CS*) := CPL;
Push error code if exception;
IF interrupt gate THEN IF := 0; (*interrupt flag disabled*)
TF := 0;
NT := 0;
```

```

INTERRUPT_TO_SAME_PRIVILEGE:
  IF 32-bit gate THEN
    Current stack limits must allow pushing 12 bytes
    ELSE #SS(0);
  IF interrupt caused by exception with error code THEN
    Stack limits must allow pushing 2 more bytes
    ELSE #SS(0);
  gate_offset must be within CS limit ELSE #GP(0);
  Push(EFLAGS);
  Push(long pointer to return location); (*3 words pad to 4*)
  CS:EIP := selector:offset from gate;
ELSE (*16-bit gate*)
  Current stack limits must allow pushing 6 bytes
  ELSE #SS(0);
  IF interrupt caused by exception with error code THEN
    Stack limits must allow pushing 2 more bytes
    ELSE #SS(0);
  gate_offset must be in CS limit ELSE #GP(0);
  Push(FLAGS);
  Push(long pointer to return location); (*2 words*)
  CS:IP := selector:offset from gate;
ENDIFELSE;

  Load CS descriptor into CS cache;
  RPL (*of CS*) := CPL;
  Push error code (*if any*) onto stack;
  IF interrupt gate THEN IF := 0; (*clear interrupt flag*)
  TF := 0;
  NT := 0;
INTERRUPT_FROM_VIRTUAL8086_MODE:
  tempEFlags := EFLAGS;
  VM := 0;
  TF := 0;
  IF service through task gate THEN GOTO TASK_GATE;
  ELSE (*service through trap or interrupt gate*)
    IF interrupt gate THEN IF := 0; (*Clear interrupt flag*)
    tempSS := SS;
    tempESP := ESP;
    SS := TSS.SS0; (*Change to level 0 stack segment*)
    ESP := TSS.ESP0; (*Change to level 0 stack pointer*)
    Push(GS); (*padded to 2 words*)
    Push(FS); (*padded to 2 words*)
    Push(DS); (*padded to 2 words*)
    Push(ES); (*padded to 2 words*)
  
```

```
GS := 0;
FS := 0;
DS := 0;
ES := 0;
Push(TempSS); (*padded to 2 words*)
Push(TempESP);
Push(TempEFlags);
Push(CS); (*padded to 2 words*)
Push(EIP);
CS:EIP := selector:offset from trap or interrupt gate;
(*starts execution of new routine in protected mode*)
TASK_GATE:
(*Examine selector to TSS in task gate descriptor: *)
  IF TSS selector specifies local in local/global bit THEN
    #TS(TSS selector);
  IF index NOT within GDT limits THEN #TS(TSS selector);
SwitchTasks (*with nesting*) to TSS;
IF interrupt caused by exception with error code THEN
  Stack limits must allow pushing 2 more bytes ELSE SS(0);
  Push error code onto stack;
ENDIF;
(E)IP must be in CS limit ELSE #GP(0);
```

### Discussion

The `INT n` instruction gives control to an interrupt procedure via software. The immediate operand gives the index number (0 to 255) into the interrupt descriptor table (IDT) for the routine called. In protected mode, the IDT consists of an array of 8-byte descriptors; each descriptor must indicate an interrupt, trap, or task gate. In real address mode, the IDT is an array of 4 byte-long pointers. In protected and real address modes, the base linear address of the IDT is defined by the contents of the IDTR.

The `INTO` conditional software instruction is identical to the `INT n` instruction except that the interrupt number is implicitly 4, and the interrupt is made only if the processor overflow flag is set.

The first 32 interrupts are reserved by Intel for system use. Some of these interrupts are used for internally generated exceptions.

`INT n` behaves like a far call except that the flags register is pushed onto the stack before the return address. Interrupt procedures return via the `IRET/IRETD` instruction, which pops the flags and return address from the stack.

In real address mode, `INT n` pushes the flags, CS, and the return IP onto the stack and then jumps to the long pointer indexed by the interrupt number.

## Flags Affected

None

## Exceptions by Mode

### Protected

#GP, #NP, #SS, and #TS as described in the Operation section

### Real Address

None; if SP or ESP = 1, 3, or 5 before executing `INT` or `INTO`, the processor will shut down due to insufficient stack space

### Virtual 8086

For `INT n` only, #GP(0) if IOPL is less than 3 to allow emulation; Interrupt 3 (OCCH) generates Interrupt 3; `INTO` generates Interrupt 4 if the overflow flag equals 1

**INVD** Invalidate Data Cache (not available on Intel386 or 376 processors)

| Opcode | Instruction | Clocks | Description                    |
|--------|-------------|--------|--------------------------------|
| 0F 08  | INVD        | —      | Destructively flush data cache |

## Operation

```
FOR ALL CacheEntries DO  
  Bit[CacheEntry,Valid] := 0;
```

## Discussion

INVD destructively invalidates (flushes) the data cache of all entries. The entries are flushed by resetting their valid bits. This instruction takes no operand.

## Flags Affected

None

## Exceptions by Mode

## Protected

None

## Real Address

None

## Virtual 8086

None

**INVLPG** Invalidate Paging Cache Entry  
(not available on Intel386 or 376 processors)

| Opcode   | Instruction     | Clocks | Description                                |
|----------|-----------------|--------|--------------------------------------------|
| 0F 01 /7 | INVLPG <i>m</i> | —      | Invalidate paging cache entry for <i>m</i> |

### Operation

```
VirtualAddr := Segment + Addr(m);
IF VirtualAddr IN PagingCache THEN
  Bit[PageCacheEntry,0] := 0;
```

### Discussion

INVLPG invalidates (flushes) a page entry from the 486 processor's on-chip paging cache (translation lookaside buffer). The full virtual address of *m* is generated. The paging cache is then checked to see if the corresponding entry for that virtual address exists in the cache. If so, the entry is flushed by resetting the Present bit (bit 0).

Only memory operands are valid with this instruction.

### Flags Affected

None

### Exceptions by Mode

#### Protected

#UD if a register operand is used.

#### Real Address

None

#### Virtual 8086

None

## IRET/IRETD Interrupt Return

| Opcode | Instruction | Clocks                          | Description                                      |
|--------|-------------|---------------------------------|--------------------------------------------------|
| CF     | IRET        | 22, <i>pm</i> =38               | 16-bit interrupt return (far return, pop flags)  |
| CF     | IRET        | <i>pm</i> =82                   | 16-bit interrupt return to lesser privilege      |
| CF     | IRET        | <i>pm</i> =214-275 <sup>†</sup> | 16-bit interrupt return different task (NT = 1)  |
| CF     | IRETD       | 22, <i>pm</i> =38               | 32-bit interrupt return (far return, pop flags)  |
| CF     | IRETD       | <i>pm</i> =60                   | 32-bit interrupt return to virtual 8086 mode     |
| CF     | IRETD       | <i>pm</i> =82                   | 32-bit interrupt return to lesser privilege      |
| CF     | IRETD       | <i>pm</i> =214-275 <sup>†</sup> | 32-bit interrupt return, different task (NT = 1) |

<sup>†</sup> See also: 80386 Programmer's Reference Manual

## Operation

```
IF PE = 0 THEN (*real address mode*)
  IF OperandSize = 32 (*instruction IRETD*) THEN
    EIP := Pop( ); (*pop stack top into EIP*)
  ELSE (*instruction IRET*)
    IP := Pop( );
    CS := Pop( );
    IF OperandSize = 32 THEN
      EFLAGS := Pop( );
    ELSE (*OperandSize = 16*)
      FLAGS := Pop( );
  ELSE (*protected mode*)
    IF VM = 1 THEN #GP(0);
    IF NT = 1 THEN
      GOTO TASK_RETURN;
    ELSE
      IF VM = 1 (*in flags image on stack*) THEN
        GOTO STACK_RETURN_TO_VIRTUAL8086;
      ELSE
        GOTO STACK_RETURN;
  TASK_RETURN:
  (*Examine back link selector in TSS addressed by currentTR: *)
```

```

    Must specify global in local/global bit ELSE
    #TS(new TSS selector);
    Index must be within GDT limits ELSE #TS(new TSS selector);
    AR must specify TSS ELSE #TS(new TSS selector);
    New TSS must be busy ELSE #TS(new TSS selector);
    IF TSS NOT PRESENT THEN #NP(new TSS selector);
    (*END check back link selector*)
    SwitchTasks without nesting to TSS
    specified by back link selector;
    Mark task just abandoned as NOT busy;
    (E)IP must be within code segment limit ELSE #GP(0);

STACK_RETURN_TO_VIRTUAL8086:
    EFLAGS := SS:[ESP + 8]; (*sets VM in interrupted routine*)
    EIP := Pop( );
    CS := Pop( ); (*behaves as in 8086, due to VM = 1*)
    throwaway := Pop( ); (*Pop EFLAGS already read*)
    ES := Pop( ); (*pop 2 words; throw away high-order word*)
    DS := Pop( ); (*pop 2 words; throw away high-order word*)
    FS := Pop( ); (*pop 2 words; throw away high-order word*)
    GS := Pop( ); (*pop 2 words; throw away high-order word*)
    tempESP := Pop( );
    tempSS := Pop( );
    SS:ESP := tempSS:tempESP;
    (*resume execution in virtual 8086 mode*)

STACK_RETURN:
    IF OperandSize = 32 THEN
        Fourth word on stack must be within stack limits ELSE #SS(0);
    ELSE (*OperandSize = 16*)
        Second word on stack must be within stack limits ELSE #SS(0);
    IF return CS selector RPL < CPL THEN #GP(return selector);
    IF return selector RPL = CPL THEN
        GOTO RETURN_SAME_PRIVILEGE;
    ELSE
        GOTO RETURN_LESS_PRIVILEGED;
    RETURN_SAME_PRIVILEGE:
    IF OperandSize = 32 THEN
        Top 12 bytes on stack must be within limits ELSE #SS(0);
        Return CS selector (*at ESP+4*) must be non-null ELSE
            #GP(0);
    ELSE (*OperandSize = 16*)
        Top 6 bytes on stack must be within limits ELSE #SS(0);

```

```
Return CS selector (*at SP+2*) must be non-null ELSE
    #GP(0);
ENDIFELSE;
IF selector index NOT within its descriptor table limits THEN
    #GP(return selector);
AR must indicate code segment ELSE #GP(return selector);
IF non-conforming AND code segment DPL NOT = CPL THEN
    #GP(return selector);
IF conforming AND code segment DPL > CPL THEN
    #GP(return selector);
IF segment NOT PRESENT THEN #NP(return selector);
return_offset must be within code segment boundaries ELSE
    #GP(0);
IF OperandSize = 32 THEN
    Load CS:EIP from stack;
    Load CS cache with new code segment descriptor;
    Load EFLAGS with third dword from stack;
    (E)SP := (E)SP + 12;
ELSE (*OperandSize = 16*)
    Load CS:IP from stack;
    Load CS cache with new code segment descriptor;
    Load FLAGS with third word on stack;
    (E)SP := (E)SP + 6;

RETURN_LESS_PRIVILEGED:
    IF OperandSize = 32 THEN
        Top 20 bytes on stack must be within limits ELSE #SS(0);
    ELSE (*OperandSize = 16*)
        Top 10 bytes on stack must be within limits ELSE #SS(0);
(*Examine return CS selector and associated descriptor: *)
    IF selector is null THEN #GP(0);
    IF selector index NOT within its descriptor table limits THEN
        #GP(return selector);
    IF AR does NOT indicate code segment THEN
        #GP(return selector);
    IF non-conforming AND
code segment DPL NOT = CS selector RPL THEN
        #GP(return selector);
    IF conforming AND code segment DPL < = CPL THEN
        #GP(return selector);
    IF segment NOT PRESENT THEN #NP(return selector);
(*END check return CS selector and associated descriptor*)
(*Examine return SS selector and associated descriptor: *)
    IF selector is null THEN #GP(0);
```

```

IF selector index NOT within its descriptor table limits THEN
    #GP(SS selector);
IF selector RPL NOT = RPL of return CS selector THEN
    #GP(SS selector);
IF AR does NOT indicate writable data segment THEN
    #GP(SS selector);
IF stack segment DPL NOT = RPL of return CS selector
    THEN #GP(SS selector);
IF SS NOT PRESENT THEN #NP(SS selector);
(*END check return SS selector and associated descriptor*)
return_offset must be in code segment ELSE#GP(0);
IF OperandSize = 32 THEN
    Load CS:EIP from stack;
    Load EFLAGS with values at (ESP + 8);
ELSE (*OperandSize = 16*)
    Load CS:IP from stack;
    Load FLAGS with values at (SP+4);
ENDIFELSE;
Load SS:(E)SP from stack;
CPL := RPL of CS return selector;
Load CS cache with CS descriptor;
Load SS cache with SS descriptor;
FOR each of ES, FS, GS, and DS DO
    IF current register value NOT valid for interrupted routine
        THEN zero register and clear valid flag;
    (*To be valid, register setting must satisfy:
    Selector index is within its descriptor table limits;
    AR indicates data or readable code segment;
    IF segment is data or non-conforming code THEN
        DPL must be >= CPL or DPL must be >= RPL;*)
ENDFOR;

```

## Discussion

IRETD is a 32-bit and IRET is a 16-bit return from an interrupt routine, whatever the USE attribute (32- or 16-bit) of the containing segment. In real address mode, IRET(D) pops the (E)IP, CS, and the flags register from the stack and resumes the interrupted routine. In protected mode, the action of IRET(D) depends on the setting of the nested task flag (NT) bit in the flag register. When popping the new flag image from the stack, the IOPL bits in the flag register are changed only when CPL equals 0.

If NT equals 0, `IRET(D)` returns from an interrupt procedure without a task switch. The code that resumes execution after `IRET(D)` must be equally or less privileged than the interrupt routine (as indicated by the `RPL` bits of the CS selector popped from the stack). If the destination code is less privileged, `IRET(D)` also pops (E)SP and SS from the stack.

If NT equals 1, `IRET(D)` reverses the operation of the `CALL` or `INT` that caused a task switch. The task executing `IRET(D)` has its updated state saved in its task state segment. If the task is reentered, the code that follows `IRET(D)` is executed.

### Flags Affected

All; the flags register is popped from stack

### Exceptions by Mode

#### Protected

#GP, #NP, #TS, or #SS, as indicated in the preceding Operation section

#### Real Address

Interrupt 13 if any part of the operand being popped lies beyond address 0FFFFH

#### Virtual 8086

#GP(0) if IOPL is less than 3 to permit emulation

**Jcc** Jump if Condition is Met

| Opcode       | Instruction       | Clocks | Description                                        |
|--------------|-------------------|--------|----------------------------------------------------|
| 77 <i>cb</i> | JA <i>rel8</i>    | 7+m,3  | Jump short if above (CF=0 and ZF=0)                |
| 73 <i>cb</i> | JAE <i>rel8</i>   | 7+m,3  | Jump short if above or equal (CF=0)                |
| 72 <i>cb</i> | JB <i>rel8</i>    | 7+m,3  | Jump short if below (CF=1)                         |
| 76 <i>cb</i> | JBE <i>rel8</i>   | 7+m,3  | Jump short if below or equal (CF=1 or ZF=1)        |
| 72 <i>cb</i> | JC <i>rel8</i>    | 7+m,3  | Jump short if carry (CF=1)                         |
| E3 <i>cb</i> | JCXZ <i>rel8</i>  | 9+m,5  | Jump short if CX register is 0                     |
| E3 <i>cb</i> | JECXZ <i>rel8</i> | 9+m,5  | Jump short if ECX register is 0                    |
| 74 <i>cb</i> | JE <i>rel8</i>    | 7+m,3  | Jump short if equal (ZF=1)                         |
| 74 <i>cb</i> | JZ <i>rel8</i>    | 7+m,3  | Jump short if 0 (ZF=1)                             |
| 7F <i>cb</i> | JG <i>rel8</i>    | 7+m,3  | Jump short if greater (ZF=0 and SF=OF)             |
| 7D <i>cb</i> | JGE <i>rel8</i>   | 7+m,3  | Jump short if greater or equal (SF=OF)             |
| 7C <i>cb</i> | JL <i>rel8</i>    | 7+m,3  | Jump short if less (SF NOT = OF)                   |
| 7E <i>cb</i> | JLE <i>rel8</i>   | 7+m,3  | Jump short if less or equal (ZF=1 and SF NOT = OF) |
| 76 <i>cb</i> | JNA <i>rel8</i>   | 7+m,3  | Jump short if not above (CF=1 or ZF=1)             |
| 72 <i>cb</i> | JNAE <i>rel8</i>  | 7+m,3  | Jump short if not above or equal (CF=1)            |
| 73 <i>cb</i> | JNB <i>rel8</i>   | 7+m,3  | Jump short if not below (CF=0)                     |
| 77 <i>cb</i> | JNBE <i>rel8</i>  | 7+m,3  | Jump short if not below or equal (CF=0 and ZF=0)   |
| 73 <i>cb</i> | JNC <i>rel8</i>   | 7+m,3  | Jump short if not carry (CF=0)                     |
| 75 <i>cb</i> | JNE <i>rel8</i>   | 7+m,3  | Jump short if not equal (ZF=0)                     |
| 7E <i>cb</i> | JNG <i>rel8</i>   | 7+m,3  | Jump short if not greater (ZF=1 or SF NOT = OF)    |
| 7C <i>cb</i> | JNGE <i>rel8</i>  | 7+m,3  | Jump short if not greater or equal (SF NOT = OF)   |
| 7D <i>cb</i> | JNL <i>rel8</i>   | 7+m,3  | Jump short if not less (SF=OF)                     |
| 7F <i>cb</i> | JNLE <i>rel8</i>  | 7+m,3  | Jump short if not less or equal (ZF=0 and SF=OF)   |
| 71 <i>cb</i> | JNO <i>rel8</i>   | 7+m,3  | Jump short if not overflow (OF=0)                  |
| 7B <i>cb</i> | JNP <i>rel8</i>   | 7+m,3  | Jump short if not parity (PF=0)                    |
| 79 <i>cb</i> | JNS <i>rel8</i>   | 7+m,3  | Jump short if not sign (SF=0)                      |

**NOTE:** The first clock count is for the true condition (branch taken); the second clock count is for the false condition (branch not taken). *rel16/32* indicates that these instructions map to two; one with a 16-bit relative displacement, the other with a 32-bit relative displacement, depending on the operand size attribute of the instruction. The assembler does not allow an operand override for relative jumps.

| Opcode             | Instruction          | Clocks | Description                                       |
|--------------------|----------------------|--------|---------------------------------------------------|
| 75 <i>cb</i>       | JNZ <i>rel8</i>      | 7+m,3  | Jump short if not zero (ZF=0)                     |
| 70 <i>cb</i>       | JO <i>rel8</i>       | 7+m,3  | Jump short if overflow (OF=1)                     |
| 7A <i>cb</i>       | JP <i>rel8</i>       | 7+m,3  | Jump short if parity (PF=1)                       |
| 7A <i>cb</i>       | JPE <i>rel8</i>      | 7+m,3  | Jump short if parity even (PF=1)                  |
| 7B <i>cb</i>       | JPO <i>rel8</i>      | 7+m,3  | Jump short if parity odd (PF=0)                   |
| 78 <i>cb</i>       | JS <i>rel8</i>       | 7+m,3  | Jump short if sign (SF=1)                         |
| 74 <i>cb</i>       | JZ <i>rel8</i>       | 7+m,3  | Jump short if zero (ZF = 1)                       |
| 0F 87 <i>cw/cd</i> | JA <i>rel16/32</i>   | 7+m,3  | Jump near if above (CF=0 and ZF=0)                |
| 0F 83 <i>cw/cd</i> | JAE <i>rel16/32</i>  | 7+m,3  | Jump near if above or equal (CF=0)                |
| 0F 82 <i>cw/cd</i> | JB <i>rel16/32</i>   | 7+m,3  | Jump near if below (CF=1)                         |
| 0F 86 <i>cw/cd</i> | JBE <i>rel16/32</i>  | 7+m,3  | Jump near if below or equal (CF=1 or ZF=1)        |
| 0F 82 <i>cw/cd</i> | JC <i>rel16/32</i>   | 7+m,3  | Jump near if carry (CF=1)                         |
| 0F 84 <i>cw/cd</i> | JE <i>rel16/32</i>   | 7+m,3  | Jump near if equal (ZF=1)                         |
| 0F 84 <i>cw/cd</i> | JZ <i>rel16/32</i>   | 7+m,3  | Jump near if 0 (ZF=1)                             |
| 0F 8F <i>cw/cd</i> | JG <i>rel16/32</i>   | 7+m,3  | Jump near if greater (ZF=0 and SF=OF)             |
| 0F 8D <i>cw/cd</i> | JGE <i>rel16/32</i>  | 7+m,3  | Jump near if greater or equal (SF=OF)             |
| 0F 8C <i>cw/cd</i> | JL <i>rel16/32</i>   | 7+m,3  | Jump near if less (SF NOT = OF)                   |
| 0F 8E <i>cw/cd</i> | JLE <i>rel16/32</i>  | 7+m,3  | Jump near if less or equal (ZF=1 and SF NOT = OF) |
| 0F 86 <i>cw/cd</i> | JNA <i>rel16/32</i>  | 7+m,3  | Jump near if not above (CF=1 or ZF=1)             |
| 0F 82 <i>cw/cd</i> | JNAE <i>rel16/32</i> | 7+m,3  | Jump near if not above or equal (CF=1)            |
| 0F 83 <i>cw/cd</i> | JNB <i>rel16/32</i>  | 7+m,3  | Jump near if not below (CF=0)                     |
| 0F 87 <i>cw/cd</i> | JNBE <i>rel16/32</i> | 7+m,3  | Jump near if not below or equal (CF=0 and ZF=0)   |
| 0F 83 <i>cw/cd</i> | JNC <i>rel16/32</i>  | 7+m,3  | Jump near if not carry (CF=0)                     |
| 0F 85 <i>cw/cd</i> | JNE <i>rel16/32</i>  | 7+m,3  | Jump near if not equal (ZF=0)                     |
| 0F 8E <i>cw/cd</i> | JNG <i>rel16/32</i>  | 7+m,3  | Jump near if not greater (ZF=1 or SF NOT = OF)    |
| 0F 8C <i>cw/cd</i> | JNGE <i>rel16/32</i> | 7+m,3  | Jump near if not greater or equal (SF NOT = OF)   |

**NOTE:** The first clock count is for the true condition (branch taken); the second clock count is for the false condition (branch not taken). *rel16/32* indicates that these instructions map to two; one with a 16-bit relative displacement, the other with a 32-bit relative displacement, depending on the operand size attribute of the instruction. The assembler does not allow an operand override for relative jumps.

| Opcode             | Instruction          | Clocks | Description                                     |
|--------------------|----------------------|--------|-------------------------------------------------|
| 0F 8D <i>cw/cd</i> | JNL <i>rel16/32</i>  | 7+m,3  | Jump near if not less (SF=OF)                   |
| 0F 8F <i>cw/cd</i> | JNLE <i>rel16/32</i> | 7+m,3  | Jump near if not less or equal (ZF=0 and SF=OF) |
| 0F 81 <i>cw/cd</i> | JNO <i>rel16/32</i>  | 7+m,3  | Jump near if not overflow (OF=0)                |
| 0F 8B <i>cw/cd</i> | JNP <i>rel16/32</i>  | 7+m,3  | Jump near if not parity (PF=0)                  |
| 0F 89 <i>cw/cd</i> | JNS <i>rel16/32</i>  | 7+m,3  | Jump near if not sign (SF=0)                    |
| 0F 85 <i>cw/cd</i> | JNZ <i>rel16/32</i>  | 7+m,3  | Jump near if not zero (ZF=0)                    |
| 0F 80 <i>cw/cd</i> | JO <i>rel16/32</i>   | 7+m,3  | Jump near if overflow (OF=1)                    |
| 0F 8A <i>cw/cd</i> | JP <i>rel16/32</i>   | 7+m,3  | Jump near if parity (PF=1)                      |
| 0F 8A <i>cw/cd</i> | JPE <i>rel16/32</i>  | 7+m,3  | Jump near if parity even (PF=1)                 |
| 0F 8B <i>cw/cd</i> | JPO <i>rel16/32</i>  | 7+m,3  | Jump near if parity odd (PF=0)                  |
| 0F 88 <i>cw/cd</i> | JS <i>rel16/32</i>   | 7+m,3  | Jump near if sign (SF=1)                        |
| 0F 84 <i>cw/cd</i> | JZ <i>rel16/32</i>   | 7+m,3  | Jump near if 0 (ZF=1)                           |

**NOTE:** The first clock count is for the true condition (branch taken); the second clock count is for the false condition (branch not taken). *rel16/32* indicates that these instructions map to two; one with a 16-bit relative displacement, the other with a 32-bit relative displacement, depending on the operand size attribute of the instruction. The assembler does not allow an operand override for relative jumps.

## Operation

```
IF condition THEN
    EIP := EIP + SignExtend(rel8/rel16/rel32);
    IF OperandSize = 16 THEN
        EIP := EIP AND 0000FFFFH;
```

## Discussion

Conditional jumps (except `JECXZ` and `JCXZ`) test the flags which have been set by a previous instruction. If the given condition is true, a jump is made to the location (label) specified as the operand. The conditions for each mnemonic are parenthesized in the Description column of the preceding table. The terms less and greater are used for comparisons of signed integers; above and below are used for unsigned integers.

Instruction coding is most efficient when the target for the conditional jump is in the current code segment and within -128 to +127 bytes of the next instruction's first byte. The jump can also target a label in the range:

- -32768 to +32767 for a `USE16` code segment.
- $-2^{31}$  to  $(+2^{31} - 1)$  for a `USE32` code segment.

When the target for the conditional jump is a far label (in a different segment), use the opposite case of the jump instruction (i.e., `JE` and `JNE`), and then access the target with an unconditional jump to the far label. For example, you cannot code:

```
JZ FARLABEL
```

You must instead code:

```
JNZ BEYOND
BEYOND:
JMP FARLABEL
```

The assembler provides more than one mnemonic for most of the conditional jump opcodes because there are several interpretations for a particular state of the flags. For example, use `JE` for a jump when two characters compared in `AX` are equal. Or, use `JZ` (a synonym for `JE`) for a jump when the result is 0 if `AX` is `AND`ed with a bit field mask.

Use `J(E)CXZ` within a conditional loop. The conditional loop instructions use an implicit limiting count in the `ECX` or `CX` register, and `J(E)CXZ` tests the contents of `(E)CX` for 0. (The other `Jcc` instructions test the flags.) `J(E)CXZ` is useful at the beginning of a conditional loop that terminates with a conditional loop instruction (such as `LOOPNE TARGET_LABEL`). `J(E)CXZ` prohibits entry to such a loop if `(E)CX` equals 0; otherwise, the loop would execute 32G or 64K times.

## Flags Affected

None

## Exceptions by Mode

### Protected

#GP(0) if the offset jumped to is beyond the limits of the code segment

### Real Address

None

### Virtual 8086

None

## JMP Jump

| Opcode       | Instruction         | Clocks                                 | Description                                          |
|--------------|---------------------|----------------------------------------|------------------------------------------------------|
| EB <i>cb</i> | JMP <i>rel8</i>     | 7+ <i>m</i>                            | Jump short                                           |
| E9 <i>cw</i> | JMP <i>rel16</i>    | 7+ <i>m</i>                            | Jump near, displacement relative to next instruction |
| FF /4        | JMP <i>r/m16</i>    | 7+ <i>m</i> /10+ <i>m</i>              | Jump near indirect                                   |
| EA <i>cd</i> | JMP <i>ptr16:16</i> | 12+ <i>m</i> , <i>pm</i> =27+ <i>m</i> | Jump intersegment, 4-byte immediate address          |
| EA <i>cd</i> | JMP <i>ptr16:16</i> | <i>pm</i> =45+ <i>m</i>                | Jump to call gate, same privilege                    |
| EA <i>cd</i> | JMP <i>ptr16:16</i> | <i>pm</i> =218-312 <sup>†</sup>        | Jump via task state segment                          |
| EA <i>cd</i> | JMP <i>ptr16:16</i> | <i>pm</i> =218-312 <sup>†</sup>        | Jump via task gate                                   |
| FF /5        | JMP <i>m16:16</i>   | 43+ <i>m</i> , <i>pm</i> =31+ <i>m</i> | Jump <i>r/m16:16</i> indirect and intersegment       |
| FF /5        | JMP <i>m16:16</i>   | <i>pm</i> =49+ <i>m</i>                | Jump to call gate, same privilege                    |
| FF /5        | JMP <i>m16:16</i>   | <i>pm</i> =223-317 <sup>†</sup>        | Jump via task state segment                          |
| FF /5        | JMP <i>m16:16</i>   | <i>pm</i> =223-317 <sup>†</sup>        | Jump via task gate                                   |
| E9 <i>cd</i> | JMP <i>rel32</i>    | 7+ <i>m</i>                            | Jump near, displacement relative to next instruction |
| FF /4        | JMP <i>r/m32</i>    | 7+ <i>m</i> ,10+ <i>m</i>              | Jump near, indirect                                  |
| EA <i>cp</i> | JMP <i>ptr16:32</i> | 12+ <i>m</i> , <i>pm</i> =27+ <i>m</i> | Jump intersegment, 6-byte immediate address          |
| EA <i>cp</i> | JMP <i>ptr16:32</i> | <i>pm</i> =45+ <i>m</i>                | Jump to call gate, same privilege                    |
| EA <i>cp</i> | JMP <i>ptr16:32</i> | <i>pm</i> =218-312 <sup>†</sup>        | Jump via task state segment                          |
| EA <i>cp</i> | JMP <i>ptr16:32</i> | <i>pm</i> =218-312 <sup>†</sup>        | Jump via task gate                                   |
| FF /5        | JMP <i>m16:32</i>   | 43+ <i>m</i> , <i>pm</i> =31+ <i>m</i> | Jump intersegment, address at <i>r/m</i> dword       |
| FF /5        | JMP <i>m16:32</i>   | <i>pm</i> =49+ <i>m</i>                | Jump to call gate, same privilege                    |
| FF /5        | JMP <i>m16:32</i>   | <i>pm</i> =223-317 <sup>†</sup>        | Jump via task state segment                          |
| FF /5        | JMP <i>m16:32</i>   | <i>pm</i> =223-317 <sup>†</sup>        | Jump via task gate                                   |

<sup>†</sup> See also: 80386 Programmer's Reference Manual

## Operation

```

IF instruction = relative JMP (*rel8/16/32 operand*) THEN
    EIP := EIP + rel8/16/32;
    IF protected mode AND destination address > its segment limit
        THEN #GP(0);
    IF OperandSize = 16 THEN
        EIP := EIP AND 0000FFFFH;
ENDIF; (*relative JMP*)
IF instruction = near indirect JMP (*r/m16/m32 operand*) THEN
    IF OperandSize = 16 THEN
        EIP := [r/m16] AND 0000FFFFH;
    ELSE (*OperandSize = 32*)
        EIP := [r/m32];
ENDIF; (*near indirect JMP*)
IF (PE = 0 OR (PE = 1 AND VM = 1)) (*real address or virtual 8086
mode*) AND instruction = far JMP (*m/ptr16:16/32 operand*) THEN
    IF operand = m16:16 OR m16:32 (*indirect*) THEN
        IF OperandSize = 16 THEN
            CS:IP := [m16:16];
            EIP := EIP AND 0000FFFFH; (*clear upper 16-bits*)
        ELSE (*OperandSize = 32*)
            CS:EIP := [m16:32];
        ENDIF; (*m16:16 or m16:32 indirect JMP*)
    IF operand = ptr16:16 or ptr16:32 (*absolute JMP*) THEN
        IF OperandSize = 16 THEN
            CS:IP := ptr16:16;
            EIP := EIP AND 0000FFFFH; (*clear upper 16-bits*)
        ELSE (*OperandSize = 32*)
            CS:EIP := ptr16:32;
        ENDIF; (*ptr16:16 or ptr16:32 absolute JMP*)

IF (PE = 1 AND VM = 0) (*protected mode*)
AND instruction = far JMP THEN
    IF operand = m16:16 OR m16:32 (*indirect*) THEN
        (*check access of dword effective address*)
        IF limit violation THEN #GP(0);
    ENDIF; (*check access*)
IF destination selector is null THEN #GP(0);
IF destination selector index NOT within its descriptor table limits
    THEN #GP(selector);
(*Examine AR of destination descriptor: *)
    IF invalid AR THEN #GP(selector);
    ELSE (*depending on AR value: *)

```

```
GOTO CONFORMING_CODE_SEGMENT;
GOTO NONCONFORMING_CODE_SEGMENT;
GOTO CALL_GATE;
GOTO TASK_GATE;
GOTO TASK_STATE_SEGMENT;

CONFORMING_CODE_SEGMENT:
  IF target_segment DPL > CPL or
     gate DPL < Max(CPL,RPL) THEN #GP(selector);
  IF segment NOT PRESENT THEN #NP(selector);
  IF target_offset NOT within code segment limit THEN #GP(0);
  IF OperandSize = 32 THEN
    Load CS:EIP from destination pointer;
  ELSE
    Load CS:IP from destination pointer;
  Load CS cache with new segment descriptor;

NONCONFORMING_CODE_SEGMENT:
  IF gate DPL < Max(CPL,RPL) THEN #GP(selector);
  IF target_segment DPL NOT = CPL THEN #GP(selector);
  IF segment NOT PRESENT THEN #NP(selector);
  IF target_offset NOT within code segment limit THEN #GP(0);
  IF OperandSize = 32 THEN
    Load CS:EIP from destination pointer;
  ELSE
    Load CS:IP from destination pointer;
  Load CS cache with new segment descriptor;
  RPL (*of CS*) := CPL;

CALL_GATE:
  IF descriptor DPL < CPL THEN #GP(gate selector);
  IF descriptor DPL < gate selector RPL THEN
    #GP(gate selector);
  IF gate NOT PRESENT THEN #NP(gate selector);
  (*Examine selector to code segment in call gate descriptor: *)
  IF selector is null THEN #GP(0);
  IF selector NOT within its descriptor table limits THEN
    #GP(CS selector);
  IF descriptor AR indicates non-code segment THEN
    #GP(CS selector);
  IF nonconforming AND
     code segment descriptor DPL NOT = CPL THEN
    #GP(CS selector);
  IF conforming AND
     code segment descriptor DPL > CPL THEN
```

```

    #GP(CS selector);
    IF code segment NOT PRESENT THEN #NP(CS selector);
    IF target_offset NOT within code segment limit THEN
        #GP(0);
    (*END check code segment selector in call gate descriptor*)
    IF OperandSize = 32 THEN
        Load CS:EIP from call gate;
    ELSE
        Load CS:IP from call gate;
        Load CS cache with new code segment descriptor;
        RPL (*of CS*) := CPL;

TASK_GATE:
    IF gate descriptor DPL < CPL THEN #TS(gate selector);
    IF gate descriptor DPL < gate selector RPL THEN
        #TS(gate selector);
    IF task gate NOT PRESENT THEN #NP(gate selector);
    (*Examine selector to TSS given in task gate descriptor: *)
    IF selector specifies local in local/global bit THEN
        #TS(TSS selector);
    IF index NOT within GDT limits THEN #TS(TSS selector);
    (*END check TSS selector given in task gate descriptor*)
    SwitchTasks (*without nesting*) to TSS;
    IF (E)IP NOT within code segment limit THEN #TS(0);

TASK_STATE_SEGMENT:
    IF TSS DPL < CPL THEN #TS(TSS selector);
    IF TSS DPL < TSS selector RPL THEN #TS(TSS selector);
    SwitchTasks (*without nesting*) to TSS;
    IF (E)IP NOT within code segment limit THEN #TS(0);

```

## Discussion

The `JMP` instruction transfers control to a different point in the instruction stream without recording return information.

The assembler automatically generates the correct form and sets the operand size attribute of the instruction according to the type of label:

**Table 6-20. JMP Label Types, Operand Sizes and Instructions**

| Operand Size | Instruction Chosen                     | Label Type                                      |
|--------------|----------------------------------------|-------------------------------------------------|
| †            | E8 <i>cd</i> <code>JMP rel8</code>     | NEAR (short within code segment)                |
| †            | E9 <i>cw</i> <code>JMP rel16</code>    | NEAR within USE16 code segment                  |
| †            | E9 <i>cd</i> <code>JMP rel32</code>    | NEAR within USE32 code segment                  |
| †            | FF /4 <code>JMP r16</code>             | NEAR (label in register and USE16 code segment) |
| †            | FF /4 <code>JMP r32</code>             | NEAR (label in register and USE32 code segment) |
| 16           | FF /4 <code>JMP m16</code>             | memory indirect NEAR USE16 code segment         |
| 32           | FF /4 <code>JMP m32</code>             | memory indirect NEAR USE32 code segment         |
| 16           | FF /5 <code>JMP m16:16</code>          | memory indirect FAR USE16 code segment          |
| 32           | FF /5 <code>JMP m16:32</code>          | memory indirect FAR USE32 code segment          |
| 16           | EA <i>cd</i> <code>JMP ptr16:16</code> | FAR to USE16 code segment                       |
| 32           | EA <i>cp</i> <code>JMP ptr16:32</code> | FAR to USE32 code segment                       |

† The operand size attribute defaults to the USE attribute of the code segment.

Jumps with labels of type *r/m16*, *r/m32*, *rel8*, *rel16*, and *rel32* are near jumps. They do not involve changing the segment register value.

`JMP rel8`, `JMP rel16`, and `JMP rel32` determine the destination by adding an offset to the address of the instruction following the `JMP`. The *rel16* form is used when the instruction's operand size attribute is 16-bits (USE16 segment only); *rel32* is used when the operand size attribute is 32-bits (USE32 segment only). The result is stored in the 32-bit EIP register. The upper 16-bits of EIP are cleared for a *rel16* operand so that the offset does not exceed 16-bits.

`JMP r/m16` and `JMP r/m32` specify a register or memory location from which the absolute offset is fetched. The number of bits in the offset depends on the operand size attribute.

`JMP ptr16:16` and `JMP ptr16:32` use a 4-byte or 6-byte operand as a long pointer to the destination. `JMP m16:16` and `JMP m16:32` fetch the long pointer from the memory location specified (indirection).

In real address or virtual 8086 mode, the long pointer provides 16-bits for the CS register and 16- or 32-bits for the EIP register (depending on the operand size attribute). In protected mode, the long pointer forms of `JMP` check the access rights (AR) in the descriptor indexed by the selector part of the long pointer. Depending on the value of AR, `JMP` performs one of the following control transfers:

- A jump to a code segment at the same privilege level
- A jump to a conforming code segment (at a more privileged level)
- A task switch

See also: Protected mode control transfers, *80386 Programmer's Reference Manual*

## Flags Affected

All if a task switch takes place; none if no task switch occurs

## Exceptions by Mode

### Protected

Near direct jumps: #GP(0) if the label is beyond the code segment limits

Near indirect jumps: #GP(0) for an illegal memory operand effective address in the CS, DS, ES, FS, or GS segments; #SS(0) for an illegal address in the SS segment; #GP if the indirect offset obtained is beyond the code segment limits; #PF(fault-code) for a page fault

Far jumps: #GP, #NP, #SS, and #TS, as indicated in the Operation section

### Real Address

Interrupt 13 if any part of the operand would be outside of the address space from 0 to 0FFFFH

### Virtual 8086

Same as Real Address Mode; #PF(fault-code) for a page fault

## LAHF Load Flags into AH Register

| Opcode | Instruction | Clocks | Description                                   |
|--------|-------------|--------|-----------------------------------------------|
| 9F     | LAHF        | 2      | Load AH with flags SF ZF xx AF xx PF<br>xx CF |

### Operation

(AH) := (SF) : (ZF) : xx : (AF) : xx : (PF) : xx : (CF) ;

### Discussion

LAHF transfers the low byte of the flag dword to AH. The bits, from MSB to LSB, are sign, zero, indeterminate, auxiliary, carry, indeterminate, parity, indeterminate, and carry.

### Flags Affected

None

### Exceptions by Mode

### Protected

None

### Real Address

None

### Virtual 8086

None

## LAR Load Access Rights

| Opcode   | Instruction          | Clocks           | Description                                   |
|----------|----------------------|------------------|-----------------------------------------------|
| 0F 02 /r | LAR <i>r16,r/m16</i> | <i>pm</i> =15/16 | <i>r16</i> := <i>r/m16</i> masked by FF00     |
| 0F 02 /r | LAR <i>r32,r/m32</i> | <i>pm</i> =15/16 | <i>r32</i> := <i>r/m32</i> masked by 00FxFF00 |

## Operation

```

IF selector index NOT within its table limits
OR ( (descriptor (*selected by Src*) does
      NOT indicate conforming code segment)
      AND (CPL > DPL (*of descriptor*)
            OR RPL (*of Src*) > DPL) )
OR
descriptor (*selected by Src*) is Invalid
(*see Table 6-21*)
THEN
  ZF := 0;
ELSE
  ZF := 1;
  temp := second dword of selected descriptor;
  IF OperandSize = 32 THEN
    Dest := temp AND 00FxFF00H;
  ELSE (*OperandSize = 16*)
    Dest := (Truncate(temp)) AND FF00H;

```

## Discussion

LAR loads the destination register (first operand) with the segment descriptor's access rights that it obtains from the second operand; the second operand should be a selector. LAR clears ZF if:

- The selector (second operand) index is outside its table limits.
- The associated descriptor does not indicate a conforming code segment, and the current privilege level or the selector's privilege level does not permit access to the descriptor.
- The AR of the descriptor has an invalid type field value (see Table 6-21).

Otherwise, LAR sets ZF and loads a masked form of the second dword of the descriptor. LAR masks this dword with 00FxFF00 and loads the result (or its lower 16-bits) into the destination register. The X in the 32-bit mask value indicates that the upper 4-bits of the limit field are undefined in the value loaded by LAR.

All code and data segment descriptors are valid for LAR. The valid/invalid system descriptor types for LAR are the following:

**Table 6-21. System Descriptor Types for LAR**

| Type | Valid/Invalid | Name                              |
|------|---------------|-----------------------------------|
| 0    | Invalid       | Invalid                           |
| 1    | Valid         | Available 286 processor TSS       |
| 2    | Valid         | LDT                               |
| 3    | Valid         | Busy 286 processor TSS            |
| 4    | Valid         | 286 processor call gate           |
| 5    | Valid         | 286/Intel386 processor task gate  |
| 6    | Valid         | 286 processor trap gate           |
| 7    | Valid         | 286 processor interrupt gate      |
| 8    | Invalid       | Invalid                           |
| 9    | Valid         | Available Intel386 processor TSS  |
| A    | Invalid       | Invalid                           |
| B    | Valid         | Busy Intel386 processor TSS       |
| C    | Valid         | Intel386 processor call gate      |
| D    | Invalid       | Invalid                           |
| E    | Valid         | Intel386 processor trap gate      |
| F    | Valid         | Intel386 processor interrupt gate |

## Flags Affected

ZF as described in the Discussion section

## Exceptions by Mode

### Protected

#GP(0) for an illegal memory operand effective address in the CS, DS, ES, FS, or GS segments; #SS(0) for an illegal address in the SS segment; #PF(fault-code) for a page fault

**Real Address**

Interrupt 6; `LAR` is not recognized in Real Address Mode

**Virtual 8086**

Same as Real Address Mode

**LDS/LES/LFS/LGS/LSS** Load Full Pointer

| Opcode   | Instruction           | Clocks           | Description                                  |
|----------|-----------------------|------------------|----------------------------------------------|
| C5 /r    | LDS <i>r16,m16:16</i> | 7, <i>pm</i> =22 | Load DS: <i>r16</i> with pointer from memory |
| C5 /r    | LDS <i>r32,m16:32</i> | 7, <i>pm</i> =22 | Load DS: <i>r32</i> with pointer from memory |
| 0F B2 /r | LSS <i>r16,m16:16</i> | 7, <i>pm</i> =22 | Load SS: <i>r16</i> with pointer from memory |
| 0F B2 /r | LSS <i>r32,m16:32</i> | 7, <i>pm</i> =22 | Load SS: <i>r32</i> with pointer from memory |
| C4 /r    | LES <i>r16,m16:16</i> | 7, <i>pm</i> =22 | Load ES: <i>r16</i> with pointer from memory |
| C4 /r    | LES <i>r32,m16:32</i> | 7, <i>pm</i> =22 | Load ES: <i>r32</i> with pointer from memory |
| 0F B4 /r | LFS <i>r16,m16:16</i> | 7, <i>pm</i> =25 | Load FS: <i>r16</i> with pointer from memory |
| 0F B4 /r | LFS <i>r32,m16:32</i> | 7, <i>pm</i> =25 | Load FS: <i>r32</i> with pointer from memory |
| 0F B5 /r | LGS <i>r16,m16:16</i> | 7, <i>pm</i> =25 | Load GS: <i>r16</i> with pointer from memory |
| 0F B5 /r | LGS <i>r32,m16:32</i> | 7, <i>pm</i> =25 | Load GS: <i>r32</i> with pointer from memory |

**Operation**

```

CASE instruction OF
  LSS: Sreg is SS; (*load SS register*)
  LDS: Sreg is DS; (*load DS register*)
  LES: Sreg is ES; (*load ES register*)
  LFS: Sreg is FS; (*load FS register*)
  LGS: Sreg is GS; (*load GS register*)
ENDCASE;
IF mode = protected THEN
  GOTO CHECK_SREG_LOAD;
ELSE
  GOTO LOAD_SREG;
CHECK_SREG_LOAD:
  IF Sreg = SS THEN
    IF selector is null THEN #GP(0);
    IF selector index NOT within its descriptor table limits THEN
      #GP(selector);
    IF selector RPL NOT = CPL THEN #GP(selector);
    AR must indicate writable data segment
    ELSE #GP(selector);
  IF DPL (*in AR*) NOT = CPL THEN #GP(selector);
  IF segment NOT PRESENT THEN #NP(selector);
  GOTO LOAD_SREG;

```

```

(*END checks protected mode, load SS*)
IF Sreg = DS OR ES OR FS OR GS THEN
    IF selector index NOT within its descriptor table limits THEN
        #GP(selector);
    AR must indicate data or readable code segment
    ELSE #GP(selector);
    IF data or nonconforming code segment AND
    RPL > DPL (*in AR*) OR CPL > DPL THEN
        #GP(selector);
    IF segment NOT PRESENT THEN #NP(selector);
    GOTO LOAD_SREG;
(*END checks protected mode, load DS, ES, FS, or GS*)

LOAD_SREG:
    IF OperandSize = 16 THEN
        r16 := [EffectiveAddress]; (* 16-bit transfer *)
        Sreg := ([EffectiveAddress] + 2); (* 16-bit transfer *)
    ELSE (*OperandSize = 32*)
        r32 := [EffectiveAddress]; (* 32-bit transfer *)
        Sreg := ([EffectiveAddress] + 4); (* 16-bit transfer *)
    ENDIFELSE; (*OperandSize = 16 or 32*)
    IF mode = protected THEN
        Load Sreg cache with descriptor;

```

## Discussion

LDS/LES/LFS/LGS/LSS read a full pointer (second operand) from memory and store it in the selected segment register:register pair. Depending on the instruction, the 16-bit full pointer is loaded into SS, DS, ES, FS, or GS. The *r32* or *r16* (first operand) is loaded with 32- or 16-bits depending on its operand size attribute.

When a protected mode assignment is made to one of the segment registers, its associated segment register cache is also loaded. The data for the cache is obtained from the descriptor table entry for the selector.

LGS/LDS/LES/LFS can load a null selector (values 0000-0003) into the DS, ES, FS, or GS registers without causing a protection exception. However, the #GP(0) exception is raised by any subsequent attempt to access a segment whose corresponding segment register has a null selector. (No memory reference to the segment occurs.)

## Flags Affected

None

### Exceptions by Mode

#### Protected

#GP(0) for an illegal memory operand effective address in the CS, DS, ES, FS, or GS segments; #SS(0) for an illegal address in the SS segment; #UD if the second operand is a register; #GP(0) if a null selector is loaded into SS; #PF(fault-code) for a page fault

#### Real Address

Interrupt 6 if the second operand is a register; Interrupt 13 if any part of the operand would lie outside the effective address space from 0 to 0FFFFH

#### Virtual 8086

Same as Real Address Mode; #PF(fault-code) for a page fault

**LEA** Load Effective Address

| Opcode | Instruction      | Clocks | Description                                                 |
|--------|------------------|--------|-------------------------------------------------------------|
| 8D /r  | LEA <i>r16,m</i> | 2      | Store effective address for <i>m</i> in register <i>r16</i> |
| 8D /r  | LEA <i>r32,m</i> | 2      | Store effective address for <i>m</i> in register <i>r32</i> |

**Operation**

```

IF OperandSize = 16 AND AddressSize = 16 THEN
    r16 := Addr(m);
IF OperandSize = 16 AND AddressSize = 32 THEN
    r16 := Truncate(Addr(m) ); (*32-bits truncated to 16-bits*)
IF OperandSize = 32 AND AddressSize = 16 THEN
    r32 := ZeroExtend(Addr(m) ); (*16-bits extended to 32-bits*)
IF OperandSize = 32 AND AddressSize = 32 THEN
    r32 := Addr(m);

```

**Discussion**

LEA calculates the offset effective address and loads it into the 32- or 16-bit register specified as the first operand. The first operand (destination) determines LEA's operand size attribute (represented by `OperandSize` in the Operation algorithm). The `USE` attribute of the segment that contains LEA's second operand (source) determines the address size attribute (represented by `AddressSize` in the Operation algorithm). If the address size attribute does not match the operand size attribute, LEA truncates or zero-extends the second operand to fit the destination.

**Flags Affected**

None

**Exceptions by Mode****Protected**

#UD if the second operand is a register

## **LEA**

---

### **Real Address**

Interrupt 6 if the second operand is a register

### **Virtual 8086**

Same as Real Address Mode

## LEAVE High Level Procedure Exit

| Opcode | Instruction | Clocks | Description                  |
|--------|-------------|--------|------------------------------|
| C9     | LEAVE       | 4      | Set SP to BP, then pop BP    |
| C9     | LEAVE       | 4      | Set ESP to EBP, then pop EBP |

### Operation

```

IF StackAddrSize = 16 THEN
    SP := BP;
    BP := Pop( );
ELSE (*StackAddrSize = 32*)
    ESP := EBP;
    EBP := Pop( );

```

### Discussion

LEAVE reverses the actions of the ENTER instruction. By copying the frame pointer to the stack pointer, LEAVE releases the stack space used by a procedure for its local variables. The old frame pointer is popped into BP or EBP, restoring the caller's frame. A subsequent RET *n* instruction removes any parameters that were passed via the stack to the exiting procedure.

### Flags Affected

None

### Exceptions by Mode

#### Protected

#SS(0) if (E)BP does not point to a location within the limits of the current stack segment; #PF(fault-code) for a page fault

#### Real Address

Interrupt 13 if any part of the operand would lie outside the effective address space from 0 to 0FFFFH

#### Virtual 8086

Same as Real Address Mode; #PF(fault-code) for a page fault

## LGDT/LIDT Load Global/Interrupt Descriptor Table Register

| Opcode   | Instruction   | Clocks | Description             |
|----------|---------------|--------|-------------------------|
| 0F 01 /2 | LGDT <i>m</i> | 11     | Load <i>m</i> into GDTR |
| 0F 01 /3 | LIDT <i>m</i> | 11     | Load <i>m</i> into IDTR |

### Operation

```
(*OperandSize is determined by the USE attribute of the code
segment*)
IF instruction = LIDT THEN
    IF OperandSize = 16 THEN
        IDTR.Limit:Base := m16:24; (*24-bits of base loaded*)
    ELSE
        IDTR.Limit:Base := m16:32;
ELSE (*instruction = LGDT*)
    IF OperandSize = 16 THEN
        GDTR.Limit:Base := m16:24; (*24-bits of base loaded*)
    ELSE
        GDTR.Limit:Base := m16:32;
```

### Discussion

The LGDT and LIDT instructions load a linear base address and limit value from a 6-byte operand in memory into the GDTR or IDTR, respectively. LGDT/LIDT load the low-order word of the operand into the limit field. If a 32-bit operand is used, LGDT/LIDT load the high-order dword of the 6-byte operand as the base field. If a 16-bit operand is used, LGDT/LIDT load the first 3 bytes of the high-order dword as the base field; the high-order 8-bits of the 6-byte operand are not used.

LGDT and LIDT are privileged (level 0) instructions that appear in operating system software. They are the only instructions that directly load an actual linear address (i.e., not a segment relative address) in processor protected mode. LGDT/LIDT are valid in real address mode to allow power-up initialization for protected mode.

The counterpart instructions for LGDT/LIDT are SGDT/SIDT. These instructions always store into all 48-bits of the 6-byte operand. The processor SGDT/SIDT write the high-order 8 address bits for both 32- and 16-bit operands. If a preceding LGDT/LIDT loaded a 16-bit operand, SGDT/SIDT store the upper 8-bits as zeros. The 286 processor SGDT/SIDT left the upper 8-bits undefined in this case.

## Flags Affected

None

## Exceptions by Mode

### Protected

#GP(0) if the current privilege level is not 0; #UD if the source operand is a register; #GP(0) for an illegal memory operand effective address in the CS, DS, ES, FS, or GS segments; #SS(0) for an illegal address in the SS segment; #PF(fault-code) for a page fault

### Real Address

Interrupt 13 if any part of the operand would lie outside the address space from 0 to 0FFFFH; Interrupt 6 if the source operand is a register

### Virtual 8086

Same as Real Address Mode; #PF(fault-code) for a page fault

## LGDTW/LGDTD/LIDTW/LIDTD

Load Global/Interrupt Descriptor Table Register with WORD/DWORD Operand

| Opcode   | Instruction      | Clocks | Description               |
|----------|------------------|--------|---------------------------|
| 0F 01 /2 | LGDTW <i>m16</i> | 11     | Load <i>m16</i> into GDTR |
| 0F 01 /2 | LGDTD <i>m32</i> | 11     | Load <i>m32</i> into GDTR |
| 0F 01 /2 | LIDTW <i>m16</i> | 11     | Load <i>m16</i> into IDTR |
| 0F 01 /2 | LIDTD <i>m32</i> | 11     | Load <i>m32</i> into IDTR |

### Operation

```
IF instruction = LIDTW THEN
    IDTR.Limit:Base = m16:24; (* 24-bits of base loaded *)
IF instruction = LIDTD THEN
    IDTR.Limit:Base = m16:32
IF instruction = LGDTW THEN
    GDTR.Limit:Base = m16:24; (* 24-bits of base loaded *)
IF instruction = LGDTD
    GDTR.Limit:Base = m16:32
```

### Discussion

The LGDTW, LGDTD, LIDTW, and LIDTD instructions are variants of the LGDT and LIDT instructions. They load a linear base address and limit value from 6 bytes in memory into the GDTR or IDTR, respectively.

These variants allow the 16-bit or 32-bit form of the instructions to be used without hard-coding address and operand prefixes to override the USE attribute currently in effect.

For example, since the processor starts up in USE16, real address mode, if you are writing in a USE32 code segment for flat model, the LGDTW and LIDTW instructions can be used to force the correct override prefixes.

The variants automatically generate any operand or address prefixes that are necessary as follows:

| <b>Instruction</b> | <b>USE16<br/>Operand Prefix</b> | <b>USE16 Address<br/>Prefix</b> | <b>USE32 Operand<br/>Prefix</b> | <b>USE32 Address<br/>Prefix</b> |
|--------------------|---------------------------------|---------------------------------|---------------------------------|---------------------------------|
| LGDTW/LIDTW        | NO                              | NO                              | YES                             | YES                             |
| LGDTD/LIDTD        | YES                             | YES                             | NO                              | NO                              |

See also: `LGDT/LIDT` instructions for further discussion, flags affected, and exceptions, in this chapter

## LLDT Load Local Descriptor Table Register

| Opcode   | Instruction | Clocks | Description                   |
|----------|-------------|--------|-------------------------------|
| 0F 00 /2 | LLDT r/m16  | 20     | Load selector r/m16 into LDTR |

### Operation

```
IF TI (*of selector*) NOT = 0
OR descriptor (*indexed by selector*) NOT an LDT THEN
    #GP(selector);
IF LDT NOT PRESENT THEN #NP(selector);
IF selector NOT within GDT limits THEN #GP(0);
LDTR := Src;
```

### Discussion

LLDT loads the Local Descriptor Table register (LDTR). The word operand (memory or register) to LLDT should contain a selector to the Global Descriptor Table (GDT). The GDT entry should be a Local Descriptor Table descriptor. If so, then the LDTR is loaded from the entry. The selector operand can be 0; if so, the LDTR is marked invalid. All subsequent descriptor references through that LDT (except by LAR, VERR, VERW or LSL) cause a #GP exception. LLDT does not affect the descriptor cache entries for DS, ES, SS, FS, GS, and CS, nor does it change the LDT field in the task state segment. The operand size attribute has no effect on this instruction. LLDT is a privileged (level 0) instruction used only in operating system software.

### Flags Affected

None

### Exceptions by Mode

#### Protected

#GP(0) if the current privilege level is not 0; #GP(selector) if the selector operand does not point into the Global Descriptor Table, or if the entry in the GDT is not a Local Descriptor Table; #GP(0) if LDT selector is outside GDT limits; #NP(selector) if the LDT descriptor is not present; #GP(0) for an illegal memory operand effective address in the CS, DS, ES, FS, or GS segments; #SS(0) for an illegal address in the SS segment; #PF(fault-code) for a page fault

## Real Address

Interrupt 6; `LLDT` is not recognized in Real Address Mode

## Virtual 8086

Same as Real Address Mode (because the instruction is not recognized, it will not execute or perform a memory reference)

## LMSW Load Machine Status Word

| Opcode   | Instruction       | Clocks | Description                                       |
|----------|-------------------|--------|---------------------------------------------------|
| 0F 01 /6 | LMSW <i>r/m16</i> | 10/13  | Load <i>r/m16</i> into machine status word in CR0 |

### Operation

`MSW := r/m16; (*16-bits stored in MSW of CR0*)`

### Discussion

LMSW loads the machine status word from the source operand into CR0. LMSW is a privileged (level 0) instruction used only in operating system software. The operand size attribute has no effect on LMSW.

LMSW can be used to switch to protected mode. If it is, LMSW must be followed by a jump to flush the instruction queue. LMSW will not switch back to real address mode.

This instruction is provided for compatibility with the 286 processor. LMSW will not affect the ET bit. In new processor programs, use MOV CR0 rather than LMSW.

### Flags Affected

None

### Exceptions by Mode

#### Protected

#GP(0) if the current privilege level is not 0; #GP(0) for an illegal memory operand effective address in the CS, DS, ES, FS, or GS segments; #SS(0) for an illegal address in the SS segment; #PF(fault-code) for a page fault

#### Real Address

Interrupt 13 if any part of the operand would lie outside the effective address space from 0 to 0FFFFH

#### Virtual 8086

Same as Real Address Mode; #PF(fault-code) for a page fault

**LOCK** Assert Bus LOCK# Signal Prefix

| Opcode | Instruction | Clocks | Description                                      |
|--------|-------------|--------|--------------------------------------------------|
| F0     | LOCK        | 0      | Assert bus LOCK# signal for the next instruction |

**Discussion**

The **LOCK** prefix causes the processor **LOCK#** signal to be asserted during execution of the instruction that follows it. In a multiprocessor environment, this signal ensures that the processor has exclusive use of any shared memory while **LOCK#** is asserted.

The **LOCK** prefix functions only with the following instructions:

|                                  |                     |
|----------------------------------|---------------------|
| BT, BTS, BTR, BTC                | <i>mem, reg/imm</i> |
| CMPXCHG, XADD, XCHG              | <i>mem, reg</i>     |
| XCHG                             | <i>reg, mem</i>     |
| ADD, ADC, SBB, SUB, AND, OR, XOR | <i>mem, reg/imm</i> |
| NOT, NEG, INC, DEC               | <i>mem</i>          |

A **LOCK** prefix to any other instruction causes an undefined opcode exception. **XCHG** always asserts **LOCK#** regardless of the presence or absence of the **LOCK** prefix.

The integrity of the lock is not affected by the alignment of the memory field. Memory locking is observed for arbitrarily misaligned fields.

Locked access is not assured if another processor is concurrently executing an instruction that has one of the following characteristics:

- The instruction is not preceded by a **LOCK** prefix.
- The instruction is not in the preceding list.
- The instruction specifies a memory operand that does not exactly overlap the destination operand. Locking is not guaranteed for partial overlap, even if one memory operand is wholly contained within another.

The 8086, 80186, and 286 processors implement a superset of the processor **LOCK** function. 8086/80186/286 processor programs that depend on **LOCK** may not execute properly if transported to the processor.

**Flags Affected**

None

# LOCK

---

## Exceptions by Mode

### Protected

#GP(0) if the current privilege level is higher (less privileged) than IOPL; #UD if LOCK is used with an instruction not listed in the Discussion section; other exceptions can be generated by the subsequent (locked) instruction

### Real Address

Interrupt 6 if LOCK is used with an instruction not listed in the Discussion section; exceptions can still be generated by the subsequent (locked) instruction

### Virtual 8086

Same as Real Address Mode

## LODS/LODSB/LODSW/LODSD Load String Operand

| Opcode | Instruction | Clocks | Description                                   |
|--------|-------------|--------|-----------------------------------------------|
| AC     | LODS m8     | 5      | Load byte [ (E)SI] into AL, update (E)SI      |
| AD     | LODS m16    | 5      | Load word [ (E)SI] into AX, update (E)SI      |
| AD     | LODS m32    | 5      | Load dword [ (E)SI] into EAX, update (E)SI    |
| AC     | LODSB       | 5      | Load byte DS:[ (E)SI] into AL, update (E)SI   |
| AD     | LODSW       | 5      | Load word DS:[ (E)SI] into AX, update (E)SI   |
| AD     | LODSD       | 5      | Load dword DS:[ (E)SI] into EAX, update (E)SI |

### Operation

```

IF AddressSize = 16 THEN
    Use SI for SrcIndex;
ELSE (*AddressSize = 32*)
    Use ESI for SrcIndex;
IF byte instruction THEN
    AL := [SrcIndex]; (* byte load *)
    IF DF = 0 THEN IncDec := 1 ELSE IncDec := -1;
ELSE
    IF OperandSize = 16 THEN
        AX := [SrcIndex]; (* word load *)
        IF DF = 0 THEN IncDec := 2 ELSE IncDec := -2;
    ELSE (* OperandSize = 32 *)
        EAX := [SrcIndex]; (* dword load *)
        IF DF = 0 THEN IncDec := 4 ELSE IncDec := -4;
    SrcIndex := SrcIndex + IncDec;

```

### Discussion

LODS loads the AL, AX, or EAX register with the memory byte, word, or dword at the location pointed to by SI or ESI. The source index register advances after the transfer is made. If the direction flag is 0 (CLD was executed), it increments; if the direction flag is 1 (STD was executed), it decrements. The increment or decrement is 1 if a byte is loaded, 2 if a word is loaded, or 4 if a dword is loaded.

If the address size attribute for this instruction is 16-bits, SI is used for the source index register; otherwise, the address size attribute is 32-bits, and ESI is the source index register.

The address of the source data is determined solely by the contents of (E)SI, not by the `LODS` operand. Load the correct index value into (E)SI before executing `LODS`. The `USE` attribute of the code segment determines whether ESI or SI is the source index register.

The purpose of the operand is to validate segment addressability and to determine the data type. The type of the `LODS` operand determines whether a byte, word, or dword is moved. The segment addressability of the operand determines whether a segment override byte is produced.

`LODSB`, `LODSW`, `LODSD` are synonyms for the byte, word, and dword `LODS` instructions. They are simpler, but they provide no type or segment checking.

Use `LODS` within a `LOOP` construct when further processing of data moved into `AX` or `AL` is necessary. `LODS` can be preceded by the `REP` prefix, but `REP` just uses clocks with `LODS`. If `REP` is specified, the repeat count is taken from `ECX` (`USE32` segment) or `CX` (`USE16` segment).

### Flags Affected

None

### Exceptions by Mode

#### Protected

#GP(0) for an illegal memory operand effective address in the CS, DS, ES, FS, or GS segments; #SS(0) for an illegal address in the SS segment; #PF(fault-code) for a page fault

#### Real Address

Interrupt 13 if any part of the operand would lie outside the effective address space from 0 to 0FFFFH

#### Virtual 8086

Same as Real Address Mode; #PF(fault-code) for a page fault

## LOOP/LOOPcond Loop Control with (E)CX Counter

| Opcode       | Instruction        | Clocks | Description                                       |
|--------------|--------------------|--------|---------------------------------------------------|
| E2 <i>cb</i> | LOOP <i>rel8</i>   | 11+m   | DEC count; jump short if count NOT = 0            |
| E1 <i>cb</i> | LOOPE <i>rel8</i>  | 11+m   | DEC count; jump short if count NOT = 0 and ZF = 1 |
| E1 <i>cb</i> | LOOPZ <i>rel8</i>  | 11+m   | DEC count; jump short if count NOT = 0 and ZF = 1 |
| E0 <i>cb</i> | LOOPNE <i>rel8</i> | 11+m   | DEC count; jump short if count NOT = 0 and ZF = 0 |
| E0 <i>cb</i> | LOOPNZ <i>rel8</i> | 11+m   | DEC count; jump short if count NOT = 0 and ZF = 0 |

### Operation

```

IF AddressSize = 16 THEN
    CountReg := CX;
ELSE
    CountReg := ECX;
CountReg := CountReg - 1;
IF instruction = LOOP THEN
    BranchCond := CountReg NOT = 0;
ELSE
    IF instruction = LOOPE OR LOOPZ THEN
        BranchCond := (ZF = 1) AND (CountReg NOT = 0);
    IF instruction = LOOPNE or LOOPNZ THEN
        BranchCond := (ZF = 0) AND (CountReg NOT = 0);
ENDIFELSE; (*determine BranchCond*)
IF BranchCond THEN
    IF OperandSize = 16 THEN
        IP := IP + SignExtend(rel8);
    ELSE (*OperandSize = 32*)
        EIP := EIP + SignExtend(rel8);

```

### Discussion

LOOP decrements the count register without changing any of the flags. Conditions are then checked for the form of LOOP being used. If the conditions are met, a short jump is made to the label specified as the LOOP operand.

The LOOP operand must be a label in the range from 128 (decimal) bytes before the instruction to 127 bytes ahead of the instruction.

Otherwise, the assembler cannot generate the 1-byte signed displacement required by the instruction format.

The USE attribute of the segment determines the address size attribute. If the address size attribute is 16-bits, the CX register is used as the count register; otherwise the ECX register is used.

The LOOP instructions not only provide iteration control; they combine loop index management with conditional branching. Use these instructions by loading an unsigned iteration count into the count register, then code the LOOP at the end of a series of instructions to be iterated. The destination of LOOP is a label that points to the beginning of the iteration.

### Flags Affected

None

### Exceptions by Mode

#### Protected

#GP(0) if the offset jumped to is beyond the limits of the current code segment

#### Real Address

None

#### Virtual 8086

None

**LSL** Load Segment Limit

| Opcode   | Instruction          | Clocks           | Description                                                              |
|----------|----------------------|------------------|--------------------------------------------------------------------------|
| 0F 03 /r | LSL <i>r16,r/m16</i> | <i>pm</i> =20/21 | Load: <i>r16</i> := segment limit, selector <i>r/m16</i> (byte granular) |
| 0F 03 /r | LSL <i>r32,r/m32</i> | <i>pm</i> =20/21 | Load: <i>r32</i> := segment limit, selector <i>r/m32</i> (byte granular) |
| 0F 03 /r | LSL <i>r16,r/m16</i> | <i>pm</i> =25/26 | Load: <i>r16</i> := segment limit, selector <i>r/m16</i> (page granular) |
| 0F 03 /r | LSL <i>r32,r/m32</i> | <i>pm</i> =25/26 | Load: <i>r32</i> := segment limit, selector <i>r/m32</i> (page granular) |

**Operation**

```

IF selector index NOT within its table limits
OR ((descriptor (*selected by Src*) does
    NOT indicate conforming code segment)
    AND (CPL > DPL (*of selected descriptor*)
        OR RPL (*of Src*) > DPL) )
OR
    descriptor (*selected by Src*) is Invalid
    (*see Table 6-22*)
THEN
    ZF := 0;
ELSE
    ZF := 1;
temp := ZeroExtend(limit); (*of descriptor selected by Src*)
(*Convert page granularity to byte granularity*)
IF G(*granularity bit of descriptor*) = 1 THEN
    temp := (ShiftLeft(temp,12) ) OR 0FFFH;
IF OperandSize = 32 THEN
    Dest := temp;
ELSE
    Dest := Truncate(temp);

```

## Discussion

LSL loads a segment limit (second operand) into a register; this operand should be a selector.

LSL clears ZF if:

- The selector (second operand) index is outside its table limits.
- The associated descriptor does not indicate a conforming code segment, and the current privilege level or the selector's privilege level does not permit access to the descriptor.
- The access rights (AR) of the descriptor has an invalid type field value (see Table 6-22).

Otherwise, LSL sets ZF and loads the byte-granular segment limits from the descriptor. Code and data segment descriptors are valid for LSL. The valid/invalid system descriptor types for LSL are:

**Table 6-22. System Descriptor Types for LSL**

| Type | Valid/Invalid | Name                                  |
|------|---------------|---------------------------------------|
| 0    | Invalid       | Invalid                               |
| 1    | Valid         | Available Intel286 processor TSS      |
| 2    | Valid         | LDT                                   |
| 3    | Valid         | Busy Intel286 processor TSS           |
| 4    | Invalid       | Intel286 processor call gate          |
| 5    | Invalid       | Intel286/Intel386 processor task gate |
| 6    | Invalid       | Intel286 processor trap gate          |
| 7    | Invalid       | Intel286 processor interrupt gate     |
| 8    | Invalid       | Invalid                               |
| 9    | Valid         | Available Intel386 processor TSS      |
| A    | Invalid       | Invalid                               |
| B    | Valid         | Busy Intel386 processor TSS           |
| C    | Invalid       | Intel386 processor call gate          |
| D    | Invalid       | Invalid                               |
| E    | Invalid       | Intel386 processor trap gate          |
| F    | Invalid       | Intel386 processor interrupt gate     |

LSL always loads the segment limit as a byte granular value. If the descriptor has a page-granular segment limit, LSL will translate it to a byte-granular limit before loading it in the destination register by shifting left 12 the 20-bit raw limit from the descriptor, then ORing it with 00000FFFH.

## Flags Affected

ZF as described in the Discussion section

## Exceptions by Mode

### Protected

#GP(0) for an illegal memory operand effective address in the CS, DS, ES, FS, or GS segments; #SS(0) for an illegal address in the SS segments; #PF(fault-code) for a page fault

### Real Address

Interrupt 6; LSL is not recognized in Real Address Mode

### Virtual 8086

Same as Real Address Mode

## LTR Load Task Register

| Opcode   | Instruction      | Clocks          | Description                                          |
|----------|------------------|-----------------|------------------------------------------------------|
| 0F 00 /3 | LTR <i>r/m16</i> | <i>pm=23/27</i> | Load <i>r/m</i> effective address into task register |

### Operation

```
IF TI (*table index field of Src selector*) = 1 THEN
    #GP(selector);
IF selector index NOT within GDT limits THEN #GP(selector);
IF descriptor (*selected by Src*) NOT TSS or
    descriptor marked busy THEN #GP(selector);
IF B (*in descriptor*) = 1 THEN #GP(selector);
IF TSS NOT PRESENT THEN #NP(selector);
TR := r/m16;
B (*in descriptor*) := 1;
Load TSS descriptor into TR cache;
```

### Discussion

LTR loads the task register from the source register or memory location specified by the operand. The operand is a selector for a TSS descriptor. The associated TSS descriptor in the GDT is then marked busy. A task switch does not occur. LTR is a privileged (level 0) instruction used only in operating system software. The operand size attribute has no effect on this instruction.

### Flags Affected

None

### Exceptions by Mode

#### Protected

#GP(0) for an illegal memory operand effective address in the CS, DS, ES, FS, or GS segments; #SS(0) for an illegal address in the SS segment; #GP(0) if the current privilege level is not 0; #GP(selector) if the object named by the source selector is not a TSS or is already busy; #NP(selector) if the TSS is marked not present; #PF(fault-code) for a page fault

**Real Address**

Interrupt 6; LTR is not recognized in Real Address Mode

**Virtual 8086**

Same as Real Address Mode

**MOV** Move Data

| Opcode        | Instruction     | Clocks           | Description                       |
|---------------|-----------------|------------------|-----------------------------------|
| 88 /r         | MOV r/m8,r8     | 2/2              | Move byte register to r/m byte    |
| 89 /r         | MOV r/m16,r16   | 2/2              | Move word register to r/m word    |
| 89 /r         | MOV r/m32,r32   | 2/2              | Move dword register to r/m dword  |
| 8A /r         | MOV r8,r/m8     | 2/4              | Move r/m byte to byte register    |
| 8B /r         | MOV r16,r/m16   | 2/4              | Move r/m word to word register    |
| 8B /r         | MOV r32,r/m32   | 2/4              | Move r/m dword to dword register  |
| 8C /r         | MOV r/m16,Sreg  | 2/2              | Move segment register to r/m word |
| 8E /r         | MOV Sreg,r/m16  | 2/5,<br>pm=18/19 | Move r/m word to segment register |
| A0            | MOV AL,moffs8   | 4                | Move byte at (seg:offset) to AL   |
| A1            | MOV AX,moffs16  | 4                | Move word at (seg:offset) to AX   |
| A1            | MOV EAX,moffs32 | 4                | Move dword at (seg:offset) to EAX |
| A2            | MOV moffs8,AL   | 2                | Move AL to (seg:offset)           |
| A3            | MOV moffs16,AX  | 2                | Move AX to (seg:offset)           |
| A3            | MOV moffs32,EAX | 2                | Move EAX to (seg:offset)          |
| B0 + rb<br>ib | MOV reg8,imm8   | 2                | Move immediate byte to register   |
| B8 + rw<br>iw | MOV reg16,imm16 | 2                | Move immediate word to register   |
| B8 + rd<br>id | MOV reg32,imm32 | 2                | Move immediate dword to register  |
| C6 ib         | MOV r/m8,imm8   | 2/2              | Move immediate byte to r/m byte   |
| C7 iw         | MOV r/m16,imm16 | 2/2              | Move immediate word to r/m word   |
| C7 id         | MOV r/m32,imm32 | 2/2              | Move immediate dword to r/m dword |

**NOTE:** *moffs8*, *moffs16*, and *moffs32* all consist of a simple offset relative to the segment base. The 8, 16, and 32 refer to the size of the data. The address size attribute of the instruction determines the size of the offset, either 16- or 32-bits. Sreg is one of SS, DS, ES, FS, or GS.

## Operation

```

IF Dest NOT Sreg THEN
    Dest := Src;
ELSE
    IF mode NOT = protected THEN
        Sreg := r/m16;
    ELSE
        GOTO CHECK_SREG_LOAD;
CHECK_SREG_LOAD:
    IF Sreg = SS THEN
        IF selector is null THEN #GP(0);
        IF selector index NOT within its descriptor table limits THEN
            #GP(selector);
        IF selector RPL NOT = CPL THEN #GP(selector);
        AR must indicate writable data segment
            ELSE #GP(selector);
        IF DPL (*in AR*) NOT = CPL THEN #GP(selector);
        IF segment NOT PRESENT THEN #NP(selector);
        (*Disable interrupts until end of following instruction*)
        GOTO LOAD_SREG;
    (*END checks protected mode, load SS*)
    IF Sreg = DS OR ES OR FS OR GS THEN
        IF selector index NOT within its descriptor table limits
            THEN #GP(selector);
        AR must indicate data or readable code segment
            ELSE #GP(selector);
        IF data or nonconforming code segment AND
            RPL > DPL (*in AR*) OR CPL > DPL THEN
            #GP(selector);
        IF segment NOT PRESENT THEN #NP(selector);
        GOTO LOAD_SREG;
    (*END checks protected mode, load DS, ES, FS, or GS*)
LOAD_SREG:
    Sreg := r/m16;
    Load Sreg cache with descriptor;

```

## Discussion

MOV copies the second operand to the first operand.

In protected mode when the destination operand is a segment register (SS, DS, ES, etc.), then the associated register cache is also loaded. The data for the cache is obtained from the descriptor table entry for the selector. A null selector (values 0000-0003) can be loaded into the DS, ES, FS, or GS registers without causing an exception. However, the #GP(0) exception is raised by any subsequent attempt to access a segment whose corresponding segment register has a null selector. (No memory reference occurs.)

A MOV into SS inhibits all interrupts until after the execution of the next instruction (presumably a MOV into (E)SP).

## Flags Affected

None

## Exceptions by Mode

### Protected

#GP, #SS, and #NP for an invalid load into a segment register, as described in the Operation section; #GP(0) if the destination is a nonwritable segment; #GP(0) for an illegal memory operand effective address in the CS, DS, ES, FS, or GS segments; #SS(0) for an illegal address in the SS segment; #PF(fault-code) for a page fault

### Real Address

Interrupt 13 if any part of the operand would lie outside the effective address space from 0 to 0FFFFH

### Virtual 8086

Same as Real Address Mode; #PF(fault-code) for a page fault

**MOV** Move to/from Special Registers

| Opcode   | Instruction             | Clocks | Description                                                                        |
|----------|-------------------------|--------|------------------------------------------------------------------------------------|
| 0F 20 /r | MOV r32,CR0/<br>CR2/CR3 | 6      | Move control register to register                                                  |
| 0F 22 /r | MOV CR0/CR2/<br>CR3,r32 | 10/4/5 | Move register to control register                                                  |
| 0F 21 /r | MOV r32,<br>DR0-DR3     | 22     | Move debug register to register                                                    |
| 0F 21 /r | MOV r32,<br>DR6/DR7     | 14     | Move debug register to register                                                    |
| 0F 23 /r | MOV DR0-DR3,r32         | 22     | Move register to debug register                                                    |
| 0F23 /r  | MOV DR6/DR7,r32         | 16     | Move register to debug register                                                    |
| 0F 24 /r | MOV r32,TR3/<br>TR4/TR5 | —      | Move test register to register<br>(not available on Intel386 or 376<br>processors) |
| 0F 24 /r | MOV r32,TR6/TR7         | 12     | Move test register to register                                                     |
| 0F 26 /r | MOV TR3/TR4/<br>TR5,r32 | —      | Move register to test register (not<br>available on Intel386 or 376 processors)    |
| 0F 26 /r | MOV TR6/TR7,r32         | 12     | Move register to test register                                                     |

**Operation**

Dest := Src;

**Discussion**

These forms of MOV store or load the following special registers into or from a general purpose register:

- Control registers CR0, CR2, and CR3
- Debug registers DR0, DR1, DR2, DR3, DR6, and DR7
- Test registers TR3, TR4, and TR5 (not available on Intel386 or 376 processors)
- Test registers TR6 and TR7

32-bit operands are always used with these instructions, regardless of the operand size attribute. These MOVs must be executed at privilege level 0 or in real address mode; otherwise, a protection exception will be raised.

## MOV

---

The `reg` field within the `ModRM` byte specifies which of the special registers in each category is involved; the `reg` field value is identical to the integer suffix of the special register name. The two bits in the `mod` field are always 11. The `r/m` field specifies the general register involved.

### Flags Affected

OF, SF, ZF, AF, PF, and CF are undefined

### Exceptions by Mode

#### Protected

#GP(0) if the current privilege level is not 0

#### Real Address

None

#### Virtual 8086

#GP(0) if instruction execution is attempted

## MOVS/MOVS<sub>B</sub>/MOVS<sub>W</sub>/MOVS<sub>D</sub> Move String to String

| Opcode | Instruction         | Clocks | Description                           |
|--------|---------------------|--------|---------------------------------------|
| A4     | MOVS <i>m8,m8</i>   | 7      | Move byte [ (E)SI] to ES:[ (E)DI]     |
| A5     | MOVS <i>m16,m16</i> | 7      | Move word [ (E)SI] to ES:[ (E)DI]     |
| A5     | MOVS <i>m32,m32</i> | 7      | Move dword [ (E)SI] to ES:[ (E)DI]    |
| A4     | MOVS <sub>B</sub>   | 7      | Move byte DS:[ (E)SI] to ES:[ (E)DI]  |
| A5     | MOVS <sub>W</sub>   | 7      | Move word DS:[ (E)SI] to ES:[ (E)DI]  |
| A5     | MOVS <sub>D</sub>   | 7      | Move dword DS:[ (E)SI] to ES:[ (E)DI] |

### Operation

```

IF (instruction = MOVSD) OR (instruction has dword operands) THEN
    OperandSize := 32; (*Assembler action*)
ELSE
    OperandSize := 16;
IF AddressSize = 16 THEN
    Use SI for SrcIndex and DI for DestIndex;
ELSE (*AddressSize = 32*)
    Use ESI for SrcIndex and EDI for DestIndex;
IF byte type of instruction THEN
    [DestIndex] := [SrcIndex];
    IF DF = 0 THEN IncDec := 1 ELSE IncDec := -1;
ELSE
    [DestIndex] := [SrcIndex];
    IF OperandSize = 16 THEN
        IF DF = 0 THEN IncDec := 2 ELSE IncDec := -2;
    ELSE (*OperandSize = 32*)
        IF DF = 0 THEN IncDec := 4 ELSE IncDec := -4;
SrcIndex := SrcIndex + IncDec;
DestIndex := DestIndex + IncDec;

```

### Discussion

`MOVS` copies the byte, word, or dword at `[(E)SI]` to the byte, word, or dword at `ES:[(E)DI]`. The destination operand must be addressable from the ES register; no segment override is possible for the destination. A segment override can be used for the source operand; the default is DS.

The contents of `(E)SI` and `(E)DI` determine the source and destination addresses, not the `MOVS` operands. The purpose of the operands is to validate segment addressability and to determine the data type. Load the correct index values into `(E)SI` and `(E)DI` before executing the `MOVS` instruction.

`MOVSB`, `MOVSW`, and `MOVSD` are synonyms for the byte, word, and dword `MOVS` instructions. They are simpler, but they provide no type checking and no way to override the DS segment for the SI source location.

After the data is moved, both `(E)SI` and `(E)DI` advance automatically. If the direction flag is 0 (`CLD` was executed), the registers increment; if the direction flag is 1 (`STD` was executed), the registers decrement. `(E)SI` and `(E)DI` are incremented or decremented by 1 if a byte was moved, by 2 if a word was moved, or by 4 if a dword was moved.

`MOVS` can be preceded by the `REP` prefix for block movement of `(E)CX` bytes or words. (See the `REP` reference page for more information.) For 32-bit operands where strings overlap, the `REP MOV` will not overlap destructively only if:

$$\begin{aligned} &\text{Addr}(\text{Src}) \geq \text{Addr}(\text{Dest}) \text{ AND } \text{DF} = 0 \\ &\text{OR } \text{Addr}(\text{Src}) \leq \text{Addr}(\text{Dest}) \text{ AND } \text{DF} = 1. \end{aligned}$$

Use an 8- or 16-bit operand for overlapped strings that must be moved in a predictable way with `REP MOVS`.

### Flags Affected

None

### Exceptions by Mode

#### Protected

`#GP(0)` if the destination is in a nonwritable segment; `#GP(0)` for an illegal memory operand effective address in the CS, DS, ES, FS, or GS segments; `#SS(0)` for an illegal address in the SS segment; `#PF(fault-code)` for a page fault

### Real Address

Interrupt 13 if any part of the operand would lie outside the effective address space from 0 to 0FFFFH

### Virtual 8086

Same as Real Address Mode; #PF(fault-code) for a page fault

## MOV SX Move with Sign-Extend

| Opcode   | Instruction      | Clocks | Description                               |
|----------|------------------|--------|-------------------------------------------|
| 0F BE /r | MOV SX r16,r/m8  | 3/6    | Move sign-extended byte to word register  |
| 0F BE /r | MOV SX r32,r/m8  | 3/6    | Move sign-extended byte to dword register |
| 0F BF /r | MOV SX r32,r/m16 | 3/6    | Move sign-extended word to dword register |

### Operation

```
Dest := SignExtend(Src);
```

### Discussion

MOV SX reads the contents of the effective address or register as a byte or a word. It sign-extends the value to the operand size attribute of the instruction (16- or 32-bits). Then, MOV SX stores the result in the destination register.

### Flags Affected

None

### Exceptions by Mode

#### Protected

#GP(0) for an illegal memory operand effective address in the CS, DS, ES, FS, or GS segments; #SS(0) for an illegal address in the SS segment; #PF(fault-code) for a page fault

#### Real Address

Interrupt 13 if any part of the operand would lie outside the effective address space from 0 to 0FFFFH

#### Virtual 8086

Same as Real Address Mode; #PF(fault-code) for a page fault

**MOVZX** Move with Zero-Extend

| Opcode   | Instruction            | Clocks | Description                               |
|----------|------------------------|--------|-------------------------------------------|
| 0F B6 /r | MOVZX <i>r16,r/m8</i>  | 3/6    | Move zero-extended byte to word register  |
| 0F B6 /r | MOVZX <i>r32,r/m8</i>  | 3/6    | Move zero-extended byte to dword register |
| 0F B7 /r | MOVZX <i>r32,r/m16</i> | 3/6    | Move zero-extended word to dword register |

**Operation**

```
Dest := ZeroExtend(Src);
```

**Discussion**

MOVZX reads the contents of the effective address or register as a byte or a word. It zero-extends the value to the operand size attribute of the instruction (16- or 32-bits). Then, MOVZX stores the result in the destination register.

**Flags Affected**

None

**Exceptions by Mode****Protected**

#GP(0) for an illegal memory operand effective address in the CS, DS, ES, FS, or GS segments; #SS(0) for an illegal address in the SS segment; #PF(fault-code) for a page fault

**Real Address**

Interrupt 13 if any part of the operand would lie outside of the effective address space from 0 to 0FFFFH

**Virtual 8086**

Same as Real Address Mode; #PF(fault-code) for a page fault

## MUL Unsigned Multiplication of AL, AX or EAX

| Opcode | Instruction      | Clocks     | Description                                           |
|--------|------------------|------------|-------------------------------------------------------|
| F6 /4  | MUL <i>r/m8</i>  | 9-14/12-17 | Unsigned multiply (AX := AL * <i>r/m</i> byte)        |
| F7 /4  | MUL <i>r/m16</i> | 9-22/12-25 | Unsigned multiply (DX:AX := AX * <i>r/m</i> word)     |
| F7 /4  | MUL <i>r/m32</i> | 9-38/12-41 | Unsigned multiply (EDX:EAX := EAX * <i>r/m</i> dword) |

**NOTE:** The processor uses an early-out multiply algorithm. The actual number of clocks depends on the position of the most significant bit in the multiplier. Optimization occurs for both positive and negative multiplier values. Because of the early-out algorithm, clock counts given are minimum to maximum. To calculate the actual clocks, use the following formula:

```
IF m = 0 THEN ActualClock := 9;
ELSE ActualClock := max( ceiling(log2 |m|), 3) = 6 clocks;
where m is the multiplier.
```

## Operation

```
IF byte-size operation THEN
    AX := AL * r/m8;
ELSE (*word or dword operation*)
    IF OperandSize = 16 THEN
        DX:AX := AX * r/m16;
    ELSE (*OperandSize = 32*)
        EDX:EAX := EAX * r/m32;
```

## Discussion

MUL performs unsigned multiplication. Its actions depend on the size of its operand, as follows:

- A byte operand is multiplied with AL; the result is left in AX. MUL clears the carry and overflow flags (CF and OF) if AH is 0; otherwise, it sets CF and OF.
- A word operand is multiplied with AX; the result is left in DX:AX. DX contains the high-order 16-bits of the product. MUL clears CF and OF if DX is 0; otherwise, it sets CF and OF.
- A dword operand is multiplied with EAX and the result is left in EDX:EAX. EDX contains the high-order 32-bits of the product. MUL clears CF and OF if EDX is 0; otherwise, it sets CF and OF.

## Flags Affected

OF and CF as described in the Discussion section; SF, ZF, AF, and PF are undefined

## Exceptions by Mode

### Protected

#GP(0) for an illegal memory operand effective address in the CS, DS, ES, FS, or GS segments; #SS(0) for an illegal address in the SS segment; #PF(fault-code) for a page fault

### Real Address

Interrupt 13 if any part of the operand would lie outside the effective address space from 0 to 0FFFFH

### Virtual 8086

Same as Real Address Mode; #PF(fault-code) for a page fault

## NEG Two's Complement Negation

| Opcode | Instruction       | Clocks | Description                              |
|--------|-------------------|--------|------------------------------------------|
| F6 /3  | NEG <i>r/m</i> 8  | 2/6    | Two's complement negate <i>r/m</i> byte  |
| F7 /3  | NEG <i>r/m</i> 16 | 2/6    | Two's complement negate <i>r/m</i> word  |
| F7 /3  | NEG <i>r/m</i> 32 | 2/6    | Two's complement negate <i>r/m</i> dword |

### Operation

```
IF r/m = 0 THEN
    CF := 0;
ELSE
    CF := 1;
r/m := -r/m;
```

### Discussion

NEG replaces the value of a register or memory operand with its two's complement. If the operand is 0, NEG clears the carry flag; otherwise, NEG sets CF.

### Flags Affected

CF as described; OF, SF, ZF, and PF as described in Appendix A

### Exceptions by Mode

#### Protected

#GP(0) if the result is in a nonwritable segment; #GP(0) for an illegal memory operand effective address in the CS, DS, ES, FS, or GS segments; #SS(0) for an illegal address in the SS segment; #PF(fault-code) for a page fault

#### Real Address

Interrupt 13 if any part of the operand would lie outside the effective address space from 0 to 0FFFFH

#### Virtual 8086

Same as Real Address Mode; #PF(fault-code) for a page fault

**NOP** No Operation

| Opcode | Instruction | Clocks | Description  |
|--------|-------------|--------|--------------|
| 90     | NOP         | 3      | No operation |

**Discussion**

NOP performs no operation. NOP is a one-byte instruction that affects none of the machine context except that (E)IP increments.

NOP is an alias mnemonic for the XCHG (E)AX, (E)AX instruction.

**Flags Affected**

None

**Exceptions by Mode****Protected**

None

**Real Address**

None

**Virtual 8086**

None

# NOT

---

## NOT One's Complement Negation

| Opcode | Instruction      | Clocks | Description                          |
|--------|------------------|--------|--------------------------------------|
| F6 /2  | NOT <i>r/m8</i>  | 2/6    | Reverse each bit of <i>r/m</i> byte  |
| F7 /2  | NOT <i>r/m16</i> | 2/6    | Reverse each bit of <i>r/m</i> word  |
| F7 /2  | NOT <i>r/m32</i> | 2/6    | Reverse each bit of <i>r/m</i> dword |

## Operation

$r/m := \text{NOT } r/m;$

## Discussion

NOT inverts the operand. Every 1 becomes a 0, and vice versa.

## Flags Affected

None

## Exceptions by Mode

### Protected

#GP(0) if the result is in a nonwritable segment; #GP(0) for an illegal memory operand effective address in the CS, DS, ES, FS, or GS segments; #SS(0) for an illegal address in the SS segment; #PF(fault-code) for a page fault

### Real Address

Interrupt 13 if any part of the operand would lie outside the effective address space from 0 to 0FFFFH

### Virtual 8086

Same as Real Address Mode; #PF(fault-code) for a page fault

**OR** Logical Inclusive OR

| Opcode          | Instruction                    | Clocks | Description                                         |
|-----------------|--------------------------------|--------|-----------------------------------------------------|
| 0C <i>ib</i>    | OR AL, <i>imm8</i>             | 2      | OR immediate byte to AL                             |
| 0D <i>iw</i>    | OR AX, <i>imm16</i>            | 2      | OR immediate word to AX                             |
| 0D <i>id</i>    | OR EAX, <i>imm32</i>           | 2      | OR immediate dword to EAX                           |
| 80 /1 <i>ib</i> | OR <i>r/m8</i> , <i>imm8</i>   | 2/7    | OR immediate byte to <i>r/m</i> byte                |
| 81 /1 <i>iw</i> | OR <i>r/m16</i> , <i>imm16</i> | 2/7    | OR immediate word to <i>r/m</i> word                |
| 81 /1 <i>id</i> | OR <i>r/m32</i> , <i>imm32</i> | 2/7    | OR immediate dword to <i>r/m</i> dword              |
| 83 /1 <i>ib</i> | OR <i>r/m16</i> , <i>imm8</i>  | 2/7    | OR sign-extended immediate byte to <i>r/m</i> word  |
| 83 /1 <i>ib</i> | OR <i>r/m32</i> , <i>imm8</i>  | 2/7    | OR sign-extended immediate byte to <i>r/m</i> dword |
| 08 / <i>r</i>   | OR <i>r/m8</i> , <i>r8</i>     | 2/6    | OR byte register to <i>r/m</i> byte                 |
| 09 / <i>r</i>   | OR <i>r/m16</i> , <i>r16</i>   | 2/6    | OR word register to <i>r/m</i> word                 |
| 09 / <i>r</i>   | OR <i>r/m32</i> , <i>r32</i>   | 2/6    | OR dword register to <i>r/m</i> dword               |
| 0A / <i>r</i>   | OR <i>r8</i> , <i>r/m8</i>     | 2/7    | OR <i>r/m</i> byte to byte register                 |
| 0B / <i>r</i>   | OR <i>r16</i> , <i>r/m16</i>   | 2/7    | OR <i>r/m</i> word to word register                 |
| 0B / <i>r</i>   | OR <i>r32</i> , <i>r/m32</i>   | 2/7    | OR <i>r/m</i> dword to dword register               |

**Operation**

```

Dest := Dest OR Src;
CF := 0;
OF := 0;

```

**Discussion**

A corresponding result bit is 0 if both corresponding bits of the operands are 0; otherwise, the result bit is 1.

**Flags Affected**

OR clears OF and CF; SF, ZF, and PF as described in Appendix A; AF is undefined

**Exceptions by Mode****Protected**

#GP(0) if the result is in a nonwritable segment; #GP(0) for an illegal memory operand effective address in the CS, DS, ES, FS, or GS segments; #SS(0) for an illegal address in the SS segment; #PF(fault-code) for a page fault

**Real Address**

Interrupt 13 if any part of the operand would lie outside the effective address space from 0 to 0FFFFH

**Virtual 8086**

Same as Real Address Mode; #PF(fault-code) for a page fault

**OUT** Output to Port

| Opcode       | Instruction          | Clocks                                         | Description                               |
|--------------|----------------------|------------------------------------------------|-------------------------------------------|
| E6 <i>ib</i> | OUT <i>imm8</i> ,AL  | 10, <i>pm</i> =4 <sup>†</sup> /24 <sup>‡</sup> | Output byte AL to immediate port number   |
| E7 <i>ib</i> | OUT <i>imm8</i> ,AX  | 10, <i>pm</i> =4 <sup>†</sup> /24 <sup>‡</sup> | Output word AX to immediate port number   |
| E7 <i>ib</i> | OUT <i>imm8</i> ,EAX | 10, <i>pm</i> =4 <sup>†</sup> /24 <sup>‡</sup> | Output dword EAX to immediate port number |
| EE           | OUT DX,AL            | 11, <i>pm</i> =5 <sup>†</sup> /25 <sup>‡</sup> | Output byte AL to port number in DX       |
| EF           | OUT DX,AX            | 11, <i>pm</i> =5 <sup>†</sup> /25 <sup>‡</sup> | Output word AX to port number in DX       |
| EF           | OUT DX,EAX           | 11, <i>pm</i> =5 <sup>†</sup> /25 <sup>‡</sup> | Output dword EAX to port number in DX     |

<sup>†</sup> If CPL ≤ IOPL

<sup>‡</sup> If CPL > IOPL or if in virtual 8086 mode

**Operation**

```
IF (PE = 1 AND ( (VM = 1) OR (CPL > IOPL) ) THEN
(*virtual 8086 mode, or protected mode with CPL > IOPL*)
    IF NOT IOPermission(Dest, width(Dest) ) THEN #GP(0);
[Dest] := Src; (*I/O address space used*)
```

**Discussion**

OUT transfers data from the register (AL, AX, or EAX) given as the second operand to the output port numbered by the first operand. Output to any port from 0 to 65535 is performed by placing the port number in the DX register and then using an OUT instruction with DX as the first operand. If the instruction contains an eight-bit port ID, the value is zero-extended to 16-bits.

If executed in virtual 8086 mode or in protected mode with CPL greater than IOPL:

- OUT cannot access any given byte unless the I/O permission bit map has a corresponding clear bit.
- OUT also cannot access a dword or word unless it can access every byte in the dword or word.

**Flags Affected**

None

## OUT

---

### Exceptions by Mode

#### Protected

#GP(0) if the current privilege level is higher (has less privilege) than `IOPL` and any of the corresponding I/O permission bits in `TSS` equals 1

#### Real Address

None

#### Virtual 8086

#GP(0) if any of the corresponding I/O permission bits in `TSS` equals 1

**OUTS/OUTSB/OUTSW/OUTSD** Output String to Port

| Opcode | Instruction            | Clocks                                         | Description                            |
|--------|------------------------|------------------------------------------------|----------------------------------------|
| 6E     | OUTS DX, <i>r/m</i> 8  | 14, <i>pm</i> =8 <sup>†</sup> /28 <sup>‡</sup> | Output byte [ (E)SI] to port in DX     |
| 6F     | OUTS DX, <i>r/m</i> 16 | 14, <i>pm</i> =8 <sup>†</sup> /28 <sup>‡</sup> | Output word [ (E)SI] to port in DX     |
| 6F     | OUTS DX, <i>r/m</i> 32 | 14, <i>pm</i> =8 <sup>†</sup> /28 <sup>‡</sup> | Output dword [ (E)SI] to port in DX    |
| 6E     | OUTSB                  | 14, <i>pm</i> =8 <sup>†</sup> /28 <sup>‡</sup> | Output byte DS:[ (E)SI] to port in DX  |
| 6F     | OUTSW                  | 14, <i>pm</i> =8 <sup>†</sup> /28 <sup>‡</sup> | Output word DS:[ (E)SI] to port in DX  |
| 6F     | OUTSD                  | 14, <i>pm</i> =8 <sup>†</sup> /28 <sup>‡</sup> | Output dword DS:[ (E)SI] to port in DX |

<sup>†</sup> If CPL ≤ IOPL

<sup>‡</sup> If CPL > IOPL or if in virtual 8086 mode

**Operation**

```

IF AddressSize = 16 THEN
    Use SI for SrcIndex;
ELSE (* AddressSize = 32 *)
    Use ESI for SrcIndex;
IF (PE = 1) AND ( (VM = 1) OR (CPL > IOPL) ) THEN
    (*virtual 8086 mode, or protected mode with CPL > IOPL*)
    IF NOT IOPermission(Dest, width(Dest) ) THEN #GP(0);
IF byte type instruction THEN
    [DX] := [SrcIndex]; (*writes at DX I/O address*)
    IF DF = 0 THEN IncDec := 1 ELSE IncDec := -1;
ELSE (*word or dword operand*)
    [DX] := [SrcIndex];
    IF OperandSize = 16 THEN
        IF DF = 0 THEN IncDec := 2 ELSE IncDec := -2;
    ELSE (*OperandSize = 32*)
        IF DF = 0 THEN IncDec := 4 ELSE IncDec := -4;
SrcIndex := SrcIndex + IncDec;

```

**Discussion**

OUTS transfers data from the memory byte, word, or dword at the source index register to the output port numbered by DX. ESI is the source index register if the address size attribute is 32-bits; SI is the source index register if the address size attribute is 16-bits.

OUTS does not allow specification of the port number as an immediate value. The port must be addressed through the DX register. Load the correct value into DX before executing OUTS.

The source data address is determined by the contents of ESI or SI, not by the second operand. Load the correct index value into (E)SI before executing `OUTS`. The second operand determines:

- The data type: whether a byte, word, or dword is transferred
- Segment addressability: whether a segment override byte is produced, or whether the default segment register (DS) is used

After the transfer, (E)SI advances automatically. If the direction flag is 0 (CLD was executed), (E)SI increments; if the direction flag is 1 (STD was executed), (E)SI decrements. (E)SI increments or decrements by 1 if a byte is output, by 2 if a word is output, or by 4 if a dword is output.

`OUTSB`, `OUTSW`, and `OUTSD` are synonyms for the byte, word, and dword `OUTS` instructions. They are simpler, but they provide no type or segment checking.

If executed in virtual 8086 mode or in protected mode with `CPL` greater than `IOPL`:

- `OUTS` cannot access any given byte unless the I/O permission bit map has a corresponding clear bit.
- `OUTS` also cannot access a dword or word unless it can access every byte in the dword or word.

`OUTS` can be preceded by the `REP` prefix for block output of (E)CX bytes or words. See the `REP` instruction for details on this operation.

### Flags Affected

None

### Exceptions by Mode

#### Protected

#GP(0) if `CPL` is greater than `IOPL` and any of the corresponding I/O permission bits in TSS equals 1; #GP(0) for an illegal memory operand effective address in the CS, DS, or ES segments; #SS(0) for an illegal address in the SS segment; #PF(fault-code) for a page fault

**Real Address**

Interrupt 13 if any part of the operand would lie outside the effective address space from 0 to 0FFFFH

**Virtual 8086**

#GP(0) if any of the corresponding I/O permission bits in TSS equals 1; #PF(fault-code) for a page fault

**POP** Pop Stack Top

| Opcode         | Instruction    | Clocks           | Description                          |
|----------------|----------------|------------------|--------------------------------------|
| 8F /0          | POP <i>m16</i> | 5                | Pop top of stack into memory word    |
| 8F /0          | POP <i>m32</i> | 5                | Pop top of stack into memory dword   |
| 58 + <i>rw</i> | POP <i>r16</i> | 4                | Pop top of stack into word register  |
| 58 + <i>rd</i> | POP <i>r32</i> | 4                | Pop top of stack into dword register |
| 1F             | POP DS         | 7, <i>pm</i> =21 | Pop top of stack into DS             |
| 07             | POP ES         | 7, <i>pm</i> =21 | Pop top of stack into ES             |
| 0F A1          | POP FS         | 7, <i>pm</i> =21 | Pop top of stack into FS             |
| 0F A9          | POP GS         | 7, <i>pm</i> =21 | Pop top of stack into GS             |
| 17             | POP SS         | 7, <i>pm</i> =21 | Pop top of stack into SS             |

**Operation**

```

IF Dest = Sreg AND mode = protected THEN
    GOTO CHECK_SREG;
ELSE
    GOTO POP_FROM_STACK;
CHECK_SREG:
    IF Sreg = SS THEN
        IF selector is null THEN #GP(0);
        IF selector index NOT within its descriptor table limits THEN
            #GP(selector);
        IF selector RPL NOT = CPL THEN #GP(selector);
        AR must indicate writable data segment
        ELSE #GP(selector);
        IF DPL (*in AR*) NOT = CPL THEN #GP(selector);
        IF segment NOT PRESENT THEN #NP(selector);
        (*Disable interrupts until end of following instruction*)
        GOTO POP_FROM_STACK;
        (*END checks protected mode, load SS*)
    IF Sreg = DS OR ES OR FS OR GS THEN
        IF selector index NOT within its descriptor table limits THEN
            #GP(selector);
        AR must indicate data or readable code segment
        ELSE #GP(selector);
        IF data or nonconforming code segment AND

```

```

RPL > DPL (*in AR*) OR CPL > DPL THEN
    #GP(selector);
IF segment NOT PRESENT THEN #NP(selector);
GOTO POP_FROM_STACK;
(*END checks protected mode, load DS, ES, FS, or GS*)

POP_FROM_STACK:
    IF StackAddrSize = 16 THEN
        SP is StackPtr;
    ELSE
        ESP is StackPtr;
    Dest := SS:[StackPtr];
    IF Dest is Sreg AND mode = protected THEN
        Load Sreg cache with descriptor;
    StackPtr := StackPtr + (OperandSize / 8);

```

## Discussion

POP copies the top of the processor stack into its memory, register, or segment register operand. The stack pointer (E)SP is incremented by 2 for a 16-bit operand or by 4 for a 32-bit operand. SS:(E)SP then points to the new top of stack.

If the value popped was PUSHED as an immediate operand in a USE32 segment, its operand size was a full 32-bits. Only the PUSH of a 16-bit register decrements (E)SP by 2 in a USE32 segment.

If the destination operand is another segment register (DS, ES, FS, GS, or SS), the value popped must be a selector. In protected mode, loading the selector initiates automatic loading of the descriptor associated with that selector into the segment register cache. Loading DS, ES, FS, GS, or SS also initiates validation of both the selector and the descriptor information.

A null value (0000-0003) can be popped into DS, ES, FS, or GS without causing a protection exception. However, the #GP(0) exception is raised by any subsequent attempt to access a segment whose corresponding segment register has a null selector. (No memory reference occurs.)

POP SS inhibits all interrupts, including NMI (non-maskable interrupt), until after execution of the next instruction. This allows sequential execution of POP SS and POP (E)SP without danger of having an invalid stack during an interrupt. However, the LSS instruction is the preferred method of loading the SS and (E)SP registers.

POP CS causes the assembler to issue an error message. Use RET to pop from the stack into CS; RET pops both IP and CS (operand size attribute of 16-bits) or both EIP and CS (operand size attribute of 32-bits).

## POP

---

### Flags Affected

None

### Exceptions by Mode

#### Protected

#GP, #SS, and #NP if a segment register is being loaded; #SS(0) if the current top of stack is not within the stack segment; #GP(0) if the result is in a nonwritable segment; #GP(0) for an illegal memory operand effective address in the CS, DS, ES, FS, or GS segments; #SS(0) for an illegal address in the SS segment; #PF(fault-code) for a page fault

#### Real Address

Interrupt 13 if any part of the operand would lie outside the effective address space from 0 to 0FFFFH

#### Virtual 8086

Same as Real Address Mode; #PF(fault-code) for a page fault

## POPA/POPAD Pop All General Registers

| Opcode | Instruction | Clocks | Description                          |
|--------|-------------|--------|--------------------------------------|
| 61     | POPA        | 24     | Pop DI, SI, BP, BX, DX, CX, and AX   |
| 61     | POPAD       | 24     | Pop EDI, ESI, EBP, EDX, ECX, and EAX |

### Operation

```
IF OperandSize = 16 (*instruction = POPA*) THEN
    DI := Pop( );
    SI := Pop( );
    BP := Pop( );
    throwaway := Pop ( ); (* Skip SP *)
    BX := Pop( );
    DX := Pop( );
    CX := Pop( );
    AX := Pop( );
ELSE (*OperandSize = 32; instruction = POPAD*)
    EDI := Pop( );
    ESI := Pop( );
    EBP := Pop( );
    throwaway := Pop ( ); (* Skip ESP *)
    EBX := Pop( );
    EDX := Pop( );
    ECX := Pop( );
    EAX := Pop( );
```

### Discussion

POPA pops the eight 16-bit general registers and discards the SP value. POPA reverses the preceding PUSHA, restoring the general registers to their values before PUSHA was executed. DI is the first register popped.

POPAD pops the eight 32-bit general registers and discards the ESP value. POPAD reverses the preceding PUSHAD, restoring the general registers to their values before PUSHAD was executed. EDI is the first register popped.

### Flags Affected

None

### Exceptions by Mode

#### Protected

#SS(0) if the starting or ending stack address is not within the stack segment;  
#PF(fault-code) for a page fault

#### Real Address

Interrupt 13 if any part of the operand would lie outside the effective address space from 0 to 0FFFFH

#### Virtual 8086

Same as Real Address Mode; #PF(fault-code) for a page fault

## POPF/POPF Pop Stack into FLAGS or EFLAGS Register

| Opcode | Instruction | Clocks | Description                  |
|--------|-------------|--------|------------------------------|
| 9D     | POPF        | 5      | Pop top of stack into FLAGS  |
| 9D     | POPF        | 5      | Pop top of stack into EFLAGS |

### Operation

```

IF StackA
  ddrSize = 16 THEN
    SP is StackPtr;
  ELSE
    ESP is StackPtr;
  IF OperandSize = 16 THEN
    FLAGS := Pop( );
    StackPtr := StackPtr + 2;
  ELSE (*OperandSize = 32*)
    EFLAGS := Pop( );
    StackPtr := StackPtr + 4;

```

### Discussion

POPF/POPF pops the word or dword on the top of the stack and stores the value in the flags register. If the operand size attribute of the instruction is 16-bits, POPF pops a word and stores the value in FLAGS. If the operand size attribute is 32-bits, POPF pops a dword and stores the value in EFLAGS.

The EFLAGS bits 16 and 17 (VM and RF, respectively) are not affected by POPF or POPF. POPF/POPF changes the I/O privilege level only if the current privilege level is 0. Real address mode is equivalent to privilege level 0. POPF/POPF change the interrupt flag only if the current privilege level is at least as privileged as IOPL. If a POPF instruction is executed with insufficient privilege, an exception does not occur, but the privileged bits do not change.

See also: (E) FLAGS registers, Appendix A

### Flags Affected

All except VM and RF

### Exceptions by Mode

#### Protected

#SS(0) if the top of stack is not within the stack segment

#### Real Address

Interrupt 13 if any part of the operand would lie outside the effective address space from 0 to 0FFFFH

#### Virtual 8086

#GP(0) if IOPL is less than 3, to permit emulation

**PUSH** Push Operand onto the Stack

| Opcode        | Instruction       | Clocks | Description          |
|---------------|-------------------|--------|----------------------|
| FF /6         | PUSH <i>m16</i>   | 5      | Push memory word     |
| FF /6         | PUSH <i>m32</i>   | 5      | Push memory dword    |
| 50+/ <i>r</i> | PUSH <i>r16</i>   | 2      | Push register word   |
| 50+/ <i>r</i> | PUSH <i>r32</i>   | 2      | Push register dword  |
| 6A            | PUSH <i>imm8</i>  | 2      | Push immediate byte  |
| 68            | PUSH <i>imm16</i> | 2      | Push immediate word  |
| 68            | PUSH <i>imm32</i> | 2      | Push immediate dword |
| 0E            | PUSH CS           | 2      | Push CS              |
| 1E            | PUSH DS           | 2      | Push DS              |
| 06            | PUSH ES           | 2      | Push ES              |
| 0F A0         | PUSH FS           | 2      | Push FS              |
| 0F A8         | PUSH GS           | 2      | Push GS              |
| 16            | PUSH SS           | 2      | Push SS              |

**Operation**

```

IF StackAddrSize = 16 THEN
    SP is StackPtr;
ELSE
    ESP is StackPtr;
IF imm operand THEN
    IF USE32 segment THEN
        OperandSize = 32;
    ELSE (*USE16 segment*)
        OperandSize = 16;
IF Sreg operand (*CS,DS,ES,FS,GS, SS*) and USE32 segment THEN
    OperandSize = 32;
StackPtr := StackPtr - (OperandSize / 8);
SS:[StackPtr] := (Src);

```

## Discussion

`PUSH` decrements the stack pointer (`E`)`SP` and copies the operand onto the top of the stack.

In `USE16` segments, `PUSH` decrements the stack pointer by 2 if the operand size attribute of the instruction is 16-bits; otherwise, it decrements the stack pointer by 4.

In `USE32` segments, `PUSH` decrements the stack pointer by 2 if the operand is a 16-bit general register; otherwise, it decrements the stack pointer by 4.

`PUSH (E)SP` pushes the current value of the stack pointer. The 8086 `PUSH SP` instruction pushes the decremented (by 2) value of `SP`.

## Flags Affected

None

## Exceptions by Mode

### Protected

`#SS(0)` if the new value of (`E`)`SP` is outside the stack segment limit; `#GP(0)` for an illegal memory operand effective address in the `CS`, `DS`, `ES`, `FS`, or `GS` segments; `#SS(0)` for an illegal address in the `SS` segment; `#PF(fault-code)` for a page fault

### Real Address

None; if (`E`)`SP` is 1, the processor shuts down due to a lack of stack space

### Virtual 8086

Same as Real Address Mode; `#PF(fault-code)` for a page fault

## PUSHA/PUSHAD Push all General Registers

| Opcode | Instruction | Clocks | Description                                              |
|--------|-------------|--------|----------------------------------------------------------|
| 60     | PUSHA       | 18     | Push AX, CX, DX, BX, original SP, BP, SI, and DI         |
| 60     | PUSHAD      | 18     | Push EAX, ECX, EDX, EBX, original ESP, EBP, ESI, and EDI |

### Operation

```

IF OperandSize = 16 (*PUSHA instruction*) THEN
    Temp := (SP);
    Push (AX);
    Push (CX);
    Push (DX);
    Push (BX);
    Push (Temp);
    Push (BP);
    Push (SI);
    Push (DI);
    (*SP := SP - 16*)
ELSE (*OperandSize = 32, PUSHAD instruction*)
    Temp := (ESP);
    Push (EAX);
    Push (ECX);
    Push (EDX);
    Push (EBX);
    Push (Temp);
    Push (EBP);
    Push (ESI);
    Push (EDI);
    (*ESP := ESP - 32*)

```

### Discussion

PUSHA and PUSHAD save the 16-bit or 32-bit general registers, respectively, on the processor stack. PUSHA decrements the stack pointer by 16 to hold the 8 word values. PUSHAD decrements the stack pointer by 32 to hold 8 dword values.

PUSHA/PUSHAD push the registers onto the stack in the order listed in the Operation section. Therefore, they appear in the 16 or 32 new stack bytes in reverse order.

## **PUSHA/PUSHAD**

---

### **Flags Affected**

None

### **Exceptions by Mode**

#### **Protected**

#SS(0) if the starting or ending stack address is outside the stack segment limit;  
#PF(fault-code) for a page fault

#### **Real Address**

The processor shuts down before executing `PUSHA` or `PUSHAD` if (E)SP equals 1, 3, or 5; Interrupt 13 if (E)SP equals 7, 9, 11, 13, or 15

#### **Virtual 8086**

Same as Real Address Mode; #PF(fault-code) for a page fault

## PUSHF/PUSHFD Push Flags Register onto the Stack

| Opcode | Instruction | Clocks | Description |
|--------|-------------|--------|-------------|
| 9C     | PUSHF       | 4      | Push FLAGS  |
| 9C     | PUSHFD      | 4      | Push EFLAGS |

### Operation

```

IF StackAddrSize = 16 THEN
    SP is StackPtr;
ELSE
    ESP is StackPtr;
IF OperandSize = 16 THEN
    StackPtr := StackPtr - 2;
    Push(FLAGS);
ELSE (*OperandSize = 32*)
    StackPtr := StackPtr - 4;
    Push(EFLAGS);

```

### Discussion

PUSHF decrements the stack pointer by 2; PUSHFD decrements the stack pointer by 4. Then PUSHF/PUSHFD copies (E)FLAGS to the new top of stack (pointed to by SS:(E)SP).

See also: (E)FLAGS register, Appendix A

### Flags Affected

None

### Exceptions by Mode

#### Protected

#SS(0) if the new value of (E)SP is outside the stack segment boundaries

#### Real Address

None; the processor shuts down due to insufficient stack space

#### Virtual 8086

#GP(0) if IOPL is less than 3, to permit emulation

**RCL/RCR/ROL/ROR** Rotate

| Opcode          | Instruction                    | Clocks | Description                                                   |
|-----------------|--------------------------------|--------|---------------------------------------------------------------|
| D0 /2           | RCL <i>r/m8</i> ,1             | 9/10   | Rotate 9-bits (CF, <i>r/m</i> byte) left once                 |
| D2 /2           | RCL <i>r/m8</i> ,CL            | 9/10   | Rotate 9-bits (CF, <i>r/m</i> byte) left CL times             |
| C0 /2 <i>ib</i> | RCL <i>r/m8</i> , <i>imm8</i>  | 9/10   | Rotate 9-bits (CF, <i>r/m</i> byte) left <i>imm8</i> times    |
| D1 /2           | RCL <i>r/m16</i> ,1            | 9/10   | Rotate 17-bits (CF, <i>r/m</i> word) left once                |
| D3 /2           | RCL <i>r/m16</i> ,CL           | 9/10   | Rotate 17-bits (CF, <i>r/m</i> word) left CL times            |
| C1 /2 <i>ib</i> | RCL <i>r/m16</i> , <i>imm8</i> | 9/10   | Rotate 17-bits (CF, <i>r/m</i> word) left <i>imm8</i> times   |
| D1 /2           | RCL <i>r/m32</i> ,1            | 9/10   | Rotate 33-bits (CF, <i>r/m</i> dword) left once               |
| D3 /2           | RCL <i>r/m32</i> ,CL           | 9/10   | Rotate 33-bits (CF, <i>r/m</i> dword) left CL times           |
| C1 /2 <i>ib</i> | RCL <i>r/m32</i> , <i>imm8</i> | 9/10   | Rotate 33-bits (CF, <i>r/m</i> dword) left <i>imm8</i> times  |
| D0 /3           | RCR <i>r/m8</i> ,1             | 9/10   | Rotate 9-bits (CF, <i>r/m</i> byte) right once                |
| D2 /3           | RCR <i>r/m8</i> ,CL            | 9/10   | Rotate 9-bits (CF, <i>r/m</i> byte) right CL times            |
| C0 /3 <i>ib</i> | RCR <i>r/m8</i> , <i>imm8</i>  | 9/10   | Rotate 9-bits (CF, <i>r/m</i> byte) right <i>imm8</i> times   |
| D1 /3           | RCR <i>r/m16</i> ,1            | 9/10   | Rotate 17-bits (CF, <i>r/m</i> word) right once               |
| D3 /3           | RCR <i>r/m16</i> ,CL           | 9/10   | Rotate 17-bits (CF, <i>r/m</i> word) right CL times           |
| C1 /3 <i>ib</i> | RCR <i>r/m16</i> , <i>imm8</i> | 9/10   | Rotate 17-bits (CF, <i>r/m</i> word) right <i>imm8</i> times  |
| D1 /3           | RCR <i>r/m32</i> ,1            | 9/10   | Rotate 33-bits (CF, <i>r/m</i> dword) right once              |
| D3 /3           | RCR <i>r/m32</i> ,CL           | 9/10   | Rotate 33-bits (CF, <i>r/m</i> dword) right CL times          |
| C1 /3 <i>ib</i> | RCR <i>r/m32</i> , <i>imm8</i> | 9/10   | Rotate 33-bits (CF, <i>r/m</i> dword) right <i>imm8</i> times |
| D0 /0           | ROL <i>r/m8</i> ,1             | 3/7    | Rotate 8-bits <i>r/m</i> byte left once                       |
| D2 /0           | ROL <i>r/m8</i> ,CL            | 3/7    | Rotate 8-bits <i>r/m</i> byte left CL times                   |
| C0 /0 <i>ib</i> | ROL <i>r/m8</i> , <i>imm8</i>  | 3/7    | Rotate 8-bits <i>r/m</i> byte left <i>imm8</i> times          |
| D1 /0           | ROL <i>r/m16</i> ,1            | 3/7    | Rotate 16-bits <i>r/m</i> word left once                      |
| D3 /0           | ROL <i>r/m16</i> ,CL           | 3/7    | Rotate 16-bits <i>r/m</i> word left CL times                  |
| C1 /0 <i>ib</i> | ROL <i>r/m16</i> , <i>imm8</i> | 3/7    | Rotate 16-bits <i>r/m</i> word left <i>imm8</i> times         |
| D1 /0           | ROL <i>r/m32</i> ,1            | 3/7    | Rotate 32-bits <i>r/m</i> dword left once                     |
| D3 /0           | ROL <i>r/m32</i> ,CL           | 3/7    | Rotate 32-bits <i>r/m</i> dword left CL times                 |

| Opcode          | Instruction           | Clocks | Description                                             |
|-----------------|-----------------------|--------|---------------------------------------------------------|
| C1 /0 <i>ib</i> | ROL <i>r/m32,imm8</i> | 3/7    | Rotate 32-bits <i>r/m</i> dword left <i>imm8</i> times  |
| D0 /1           | ROR <i>r/m8,1</i>     | 3/7    | Rotate 8-bits <i>r/m</i> byte right once                |
| D2 /1           | ROR <i>r/m8,CL</i>    | 3/7    | Rotate 8-bits <i>r/m</i> byte right CL times            |
| C0 /1 <i>ib</i> | ROR <i>r/m8,imm8</i>  | 3/7    | Rotate 8-bits <i>r/m</i> word right <i>imm8</i> times   |
| D1 /1           | ROR <i>r/m16,1</i>    | 3/7    | Rotate 16-bits <i>r/m</i> word right once               |
| D3 /1           | ROR <i>r/m16,CL</i>   | 3/7    | Rotate 16-bits <i>r/m</i> word right CL times           |
| C1 /1 <i>ib</i> | ROR <i>r/m16,imm8</i> | 3/7    | Rotate 16-bits <i>r/m</i> word right <i>imm8</i> times  |
| D1 /1           | ROR <i>r/m32,1</i>    | 3/7    | Rotate 32-bits <i>r/m</i> dword right once              |
| D3 /1           | ROR <i>r/m32,CL</i>   | 3/7    | Rotate 32-bits <i>r/m</i> dword right CL times          |
| C1 /1 <i>ib</i> | ROR <i>r/m32,imm8</i> | 3/7    | Rotate 32-bits <i>r/m</i> dword right <i>imm8</i> times |

## Operation

```
(*RCL - Rotate through Carry Flag Left*)
temp := Count;
WHILE (temp NOT = 0) DO
    tmpCF := high-order bit of (r/m);
    r/m := r/m * 2 + CF;
    CF := tmpCF;
    temp := temp - 1;
ENDWHILE;
IF Count = 1 THEN
    IF high-order bit of r/m NOT = CF THEN
        OF := 1;
    ELSE
        OF := 0;
    ENDIF
ELSE (*Count NOT = 1*)
    OF := undefined;
(*ROL - Rotate Left*)
temp := Count;
WHILE (temp NOT = 0) DO
    tmpCF := high-order bit of (r/m);
    r/m := r/m * 2 + (tmpCF);
    temp := temp - 1;
ENDWHILE;
CF := tmpCF;
```

```
IF Count = 1 THEN
  IF high-order bit of  $r/m$  NOT = CF THEN
    OF := 1;
  ELSE
    OF := 0;
ELSE (*Count NOT = 1*)
  OF := undefined;

(*RCR - Rotate through Carry Flag Right*)
temp := Count;
WHILE (temp NOT = 0 ) DO
  tmpCF := low-order bit of ( $r/m$ );
   $r/m$  :=  $r/m$  / 2 + (CF * 2width( $r/m$ ));
  CF := tmpCF;
  temp := temp - 1;
ENDWHILE;
IF COUNT = 1 THEN
  IF (high-order bit) NOT = (next bit) (*in  $r/m$ *) THEN
    OF := 1;
  ELSE
    OF := 0;
ELSE (*Count NOT = 1*)
  OF := undefined;

(*ROR - Rotate Right*)
temp := Count;
WHILE (temp NOT = 0 ) DO
  tmpCF := low-order bit of ( $r/m$ );
   $r/m$  :=  $r/m$  / 2 + (tmpCF * 2width( $r/m$ ));
  temp := temp - 1;
ENDWHILE;
CF := tmpCF;
IF COUNT = 1 THEN
  IF (high-order bit) NOT = (next bit) (*in  $r/m$ *) THEN
    OF := 1;
  ELSE
    OF := 0;
ELSE (*Count NOT = 1*)
  OF := undefined;
```

## Discussion

RCL/RCL/ROL/ROR shift the bits of the register or memory operand.

RCL shifts all bits left, copying the carry flag (CF) into the LSB and the top bit into CF. RCL shifts all the bits downward, copying CF into the MSB and the bottom bit into CF.

ROL (left rotate) shifts all the bits upward and copies the top bit into the LSB. ROR (right rotate) shifts the bits downward and copies the bottom bit into the MSB. The original value of the carry flag is not a part of the result, but the carry flag receives a copy of the bit that was shifted from one end to the other.

The second operand is a rotation count, either the contents of CL or an immediate number in the range 1..31. The overflow flag is defined only if the second operand equals 1; otherwise, OF is undefined. After left shifts or rotates, the CF bit is XORed with the high-order result bit. After right shifts or rotates, the high-order two bits of the result are XORed to get OF. If a rotation count value is greater than 31, only the bottom five bits are used. In virtual 8086 mode, the processor masks rotation counts. The 8086 does not.

## Flags Affected

OF only for single rotates; OF is undefined for multi-bit rotates; CF as described in the Discussion section

## Exceptions by Mode

### Protected

#GP(0) if the result is in a nonwritable segment; #GP(0) for an illegal memory operand effective address in the CS, DS, ES, FS, or GS segments; #SS(0) for an illegal address in the SS segment; #PF(fault-code) for a page fault

### Real Address

Interrupt 13 if any part of the operand would lie outside the effective address space from 0 to 0FFFFH

### Virtual 8086

Same as Real Address Mode; #PF(fault-code) for a page fault

**REP/REPE/REPZ/REPNE/REPZ** Repeat String Operation

| Opcode | Instruction                  | Clocks                                             | Description                                      |
|--------|------------------------------|----------------------------------------------------|--------------------------------------------------|
| F3 6C  | REP INS <i>r/m8</i> ,DX      | 13+6*(E)CX,<br>$pm=7+6*(E)CX^1/$<br>$27+6*(E)CX^2$ | Input (E)CX bytes from port DX into ES:[ (E)DI]  |
| F3 6D  | REP INS <i>r/m16</i> ,DX     | 13+6*(E)CX,<br>$pm=7+6*(E)CX^1/$<br>$27+6*(E)CX^2$ | Input (E)CX words from port DX into ES:[ (E)DI]  |
| F3 6D  | REP INS <i>r/m32</i> ,DX     | 13+6*(E)CX,<br>$pm=7+6*(E)CX^1/$<br>$27+6*(E)CX^2$ | Input (E)CX dwords from port DX into ES:[ (E)DI] |
| F3 6C  | REP INSB                     | 13+6*(E)CX,<br>$pm=7+6*(E)CX^1/$<br>$27+6*(E)CX^2$ | Input (E)CX bytes from port DX into ES:[ (E)DI]  |
| F3 6D  | REP INSW                     | 13+6*(E)CX,<br>$27+6*(E)CX^2$                      | Input (E)CX words ES:[ (E)DI]                    |
| F3 6D  | REP INSD                     | 13+6*(E)CX,<br>$pm=7+6*(E)CX^1/$<br>$27+6*(E)CX^2$ | Input (E)CX dwords from port DX into ES:[ (E)DI] |
| F3 6E  | REP OUTS<br>DX, <i>r/m8</i>  | 5+12*(E)CX,<br>$pm=6+5*(E)CX^1/$                   | Output (E)CX bytes from [ (E)SI] to port DX      |
| F3 6F  | REP OUTS DX,<br><i>r/m16</i> | 5+12*(E)CX,<br>$pm=6+5*(E)CX^1/$<br>$26+5*(E)CX^2$ | Output (E)CX words from [ (E)SI] to DX           |
| F3 6F  | REP OUTS DX,<br><i>r/m32</i> | 5+12*(E)CX,<br>$pm=6+5*(E)CX^1/$<br>$26+5*(E)CX^2$ | Output (E)CX dwords from [ (E)SI] to port DX     |
| F3 6E  | REP OUTSB                    | 5+12*(E)CX,<br>$pm=6+5*(E)CX^1/$<br>$26+5*(E)CX^2$ | Output (E)CX bytes from DS:[ (E)SI] to port DX   |
| F3 6F  | REP OUTSW                    | 5+12*(E)CX,<br>$pm=6+5*(E)CX^1/$<br>$26+5*(E)CX^2$ | Output (E)CX words from DS:[ (E)SI] to port DX   |
| F3 6F  | REP OUTSD                    | 5+12*(E)CX,<br>$pm=6+5*(E)CX^1/$<br>$26+5*(E)CX^2$ | Output (E)CX dwords from DS:[ (E)SI] to port DX  |

<sup>1</sup> If CPL <= IOPL

<sup>2</sup> If CPL > IOPL or in virtual 8086 mode

| <b>Opcode</b> | <b>Instruction</b>         | <b>Clocks</b>      | <b>Description</b>                                  |
|---------------|----------------------------|--------------------|-----------------------------------------------------|
| F3 A4         | REP MOVS <i>m8,m8</i>      | 5+4*(E)CX          | Move (E)CX bytes from [ (E)SI]u to ES:[ (E)DI]      |
| F3 A5         | REP MOVS <i>m16, m16</i>   | 5+4*(E)CX          | Move (E)CX words from [ (E)SI] to ES:[ (E)DI]       |
| F3 A5         | REP MOVS <i>m32, m32</i>   | 5+4*(E)CX          | Move (E)CX dwords from [ (E)SI] to ES:[ (E)DI]      |
| F3 A4         | REP MOVSB                  | 5+4*(E)CX          | Move (E)CX bytes from DS: [ (E)SI] to ES:[ (E)DI]   |
| F3 A5         | REP MOVSW                  | 5+4*(E)CX          | Move (E)CX words from DS: [ (E)SI] to ES:[ (E)DI]   |
| F3 A5         | REP MOVSD                  | 5+4*(E)CX          | Move (E)CX dwords from DS: [ (E)SI] to ES:[ (E)DI]  |
| F3 AA         | REP STOS <i>m8</i>         | 5+5*(E)CX          | Fill (E)CX bytes at ES:[ (E)DI] with AL             |
| F3 AB         | REP STOS <i>m16</i>        | 5+5*(E)CX          | Fill (E)CX words at ES:[ (E)DI] with AX             |
| F3 AB         | REP STOS <i>m32</i>        | 5+5*(E)CX          | Fill (E)CX dwords at ES:[ (E)DI] with EAX           |
| F3 AA         | REP STOSB                  | 5+5*(E)CX          | Fill (E)CX bytes at ES:[ (E)DI] with AL             |
| F3 AB         | REP STOSW                  | 5+5*(E)CX          | Fill (E)CX words at ES:[ (E)DI] with AX             |
| F3 AB         | REP STOSD                  | 5+5*(E)CX          | Fill (E)CX dwords at ES:[ (E)DI] with EAX           |
| F3 A6         | REPE/Z CMPS <i>m8,m8</i>   | 5+9*N <sup>3</sup> | Find nonmatching bytes in ES:[ (E)DI] and [ (E)SI]  |
| F3 A7         | REPE/Z CMPS <i>m16,m16</i> | 5+9*N <sup>3</sup> | Find nonmatching words in ES:[ (E)DI] and [ (E)SI]  |
| F3 A7         | REPE/Z CMPS <i>m32,m32</i> | 5+9*N <sup>3</sup> | Find nonmatching dwords in ES:[ (E)DI] and [ (E)SI] |
| F3 A6         | REPE/Z CMPSB               | 5+9*N <sup>3</sup> | Find nonmatching bytes in ES: [ (E)DI] and [ (E)SI] |
| F3 A7         | REPE/Z CMPSW               | 5+9*N <sup>3</sup> | Find nonmatching words in ES:[ (E)DI] and [ (E)SI]  |
| F3 A7         | REPE/Z CMPSD               | 5+9*N <sup>3</sup> | Find nonmatching words in ES:[ (E)DI] and [ (E)SI]  |

<sup>3</sup> N denotes the number of iterations actually executed. These clock counts correspond to (E)CX iterations.

| Opcode | Instruction                     | Clocks    | Description                                       |
|--------|---------------------------------|-----------|---------------------------------------------------|
| F3 AE  | REPE/Z SCAS <i>m8</i>           | $5+8*N^3$ | Find non-AL byte starting at ES:[ (E)DI]          |
| F3 AF  | REPE/Z SCAS <i>m16</i>          | $5+8*N^3$ | Find non-AX word starting at ES:[ (E)DI]          |
| F3 AF  | REPE/Z SCAS <i>m32</i>          | $5+8*N^3$ | Find non-EAX dword starting at ES:[ (E)DI]        |
| F3 AE  | REPE/Z SCASB                    | $5+8*N^3$ | Find non-AL byte starting at ES:[ (E)DI]          |
| F3 AF  | REPE/Z SCASW                    | $5+8*N^3$ | Find non-AX word starting at ES:[ (E)DI]          |
| F3 AF  | REPE/Z SCASD                    | $5+8*N^3$ | Find non-EAX dword starting at ES:[ (E)DI]        |
| F2 A6  | REPNE/NZ CMPS<br><i>m8,m8</i>   | $5+9*N^3$ | Find matching bytes in ES:[ (E)DI] and [ (E)SI]   |
| F2 A7  | REPNE/NZ CMPS<br><i>m16,m16</i> | $5+9*N^3$ | Find matching words in ES: [ (E)DI] and [ (E)SI]  |
| F2 A7  | REPNE/NZ CMPS<br><i>m32,m32</i> | $5+9*N^3$ | Find matching dwords in ES: [ (E)DI] and [ (E)SI] |
| F2 A6  | REPNE/NZ CMPSB                  | $5+9*N^3$ | Find matching bytes in ES: [ (E)DI] and [ (E)SI]  |
| F2 A7  | REPNE/NZ<br>CMPSW               | $5+9*N^3$ | Find matching words in ES: [ (E)DI] and [ (E)SI]  |
| F2 A7  | REPNE/NZ CMPSD                  | $5+9*N^3$ | Find matching dwords in ES: [ (E)DI] and [ (E)SI] |
| F2 AE  | REPNE/NZ<br>SCAS <i>m8</i>      | $5+8*N^3$ | Find AL byte starting at ES:[ (E)DI]              |
| F2 AF  | REPNE/NZ<br>SCAS <i>m16</i>     | $5+8*N^3$ | Find AX word starting at ES: [ (E)DI]             |
| F2 AF  | REPNE/NZ<br>SCAS <i>m32</i>     | $5+8*N^3$ | Find EAX dword starting at ES:[ (E)DI]            |
| F2 AE  | REPNE/NZ SCASB                  | $5+8*N^3$ | Find AL byte starting at ES: [ (E)DI]             |
| F2 AF  | REPNE/NZ SCASW                  | $5+8*N^3$ | Find AX word starting at ES: [ (E)DI]             |
| F2 AF  | REPNE/NZ SCASD                  | $5+8*N^3$ | Find EAX dword starting at ES:[ (E)DI]            |

<sup>3</sup> *N* denotes the number of iterations actually executed. These clock counts correspond to (E)CX iterations.

## Operation

```
IF AddressSize = 16 THEN
    Use CX for CountReg;
ELSE (*AddressSize = 32*)
    Use ECX for CountReg;
WHILE CountReg NOT = 0 DO
    service pending interrupts (*if any*);
    execute primitive string instruction;
    CountReg := CountReg - 1;
    IF primitive instruction = CMPSB OR CMPSW OR CMPSD OR
    SCASB OR SCASW OR SCASD THEN
        IF (instruction is REPE OR REPZ) AND (ZF=1) THEN
            exit WHILE loop;
        IF (instruction is REPNE OR REPNZ) AND (ZF=0) THEN
            exit WHILE loop;
ENDWHILE;
```

## Discussion

REP, REPE (repeat while equal), and REPNE (repeat while not equal) prefix a string instruction. REP causes the following string instruction to repeat the number of times indicated in the count register (E)CX. REPE and REPNE cause the string instruction to repeat until the indicated condition in the zero flag is no longer met. REPZ and REPNZ are synonyms for REPE and REPNE, respectively.

REP/REPE/REPZ/REPNE/REPNZ affect only a single string instruction. Use the LOOP instruction or another looping construct to repeat a block of string instructions.

The precise action for each iteration of REP/REPE/REPZ/REPNE/REPNZ is as follows:

1. If the address size attribute is 16-bits, use CX for the count register; if the address size attribute is 32-bits, use ECX for the count register.
2. Check (E)CX. If it is zero, exit the iteration, and move to the next instruction.
3. Acknowledge any pending interrupts.
4. Perform the string operation once.
5. Decrement CX or ECX by 1; no flags are modified.

6. Check the zero flag if the string operation is `SCAS` or `CMPS`. If the repeat condition does not hold, exit the iteration and move to the next instruction. Exit the iteration if the prefix is `REPE` and `ZF` is 0 (the last comparison was not equal), or if the prefix is `REPNE` and `ZF` is 1 (the last comparison was equal).
7. Return to step 1 for the next iteration.

Repeated `CMPS` and `SCAS` instructions can be exited if the count is exhausted or if the zero flag fails the repeat condition. These two cases can be distinguished either by using the `JECXZ/JCXZ` instruction, or by using the conditional jumps that test the zero flag (`JZ`, `JNZ`, and `JNE`).

Not all input/output ports can handle the rate at which the `REP IN`s and `REP OUT`s instructions execute.

### Flags Affected

`ZF` by `REP CMPS` and `REP SCAS` as indicated in the Operation section

### Exceptions by Mode

#### Protected

#UD if `REP` is used with any instruction (except `LODS`) not listed in the preceding table; further exceptions can be generated when the string operation is executed.

See also: `LODS` and other string instructions, in this chapter

#### Real Address

Interrupt 6 if `REP` is used with any instruction (except `LODS`) not listed in the preceding table; further exceptions can be generated when the string operation is executed.

#### Virtual 8086

#UD if `REP` is used with any instruction (except `LODS`) not listed in the preceding table; further exceptions can be generated when the string operation is executed.

**RET** Return from Procedure

| Opcode | Instruction | Clocks       | Description                                     |
|--------|-------------|--------------|-------------------------------------------------|
| C3     | RET         | 10+m         | Return (near) to caller                         |
| CB     | RET         | 18+m,pm=32+m | Return (far) to caller, same privilege          |
| CB     | RET         | pm=68        | Return (far), lesser privilege, switch stacks   |
| C2 iw  | RET imm16   | 10+m         | Return (near), pop imm16 bytes of parameters    |
| CA iw  | RET imm16   | 18+m,pm=32+m | Return (far), same privilege, pop imm16 bytes   |
| CA iw  | RET imm16   | pm=68        | Return (far), lesser privilege, pop imm16 bytes |

**Operation**

```

IF instruction = near RET THEN
  IF OperandSize = 16 THEN
    IP := Pop( );
    EIP := EIP AND 0000FFFFH;
  ELSE (*OperandSize = 32*)
    EIP := Pop( );
  IF instruction has immediate operand THEN
    (E)SP := (E)SP + imm16;
ENDIF; (*near RET*)

IF (PE = 0 OR (PE = 1 AND VM = 1) ) AND instruction = far RET
THEN
  (*PE in CR0; VM in EFLAGS; real address or virtual 8086 mode*)
  IF OperandSize = 16 THEN
    IP := Pop( );
    EIP := EIP AND 0000FFFFH;
    CS := Pop( ); (*16-bit pop*)
  ELSE (*OperandSize = 32*)
    EIP := Pop( );
    CS := Pop( ); (*32-bit pop, high-order 16-bits discarded*)
  IF instruction has immediate operand THEN
    (E)SP := (E)SP + imm16;

```

```
ENDIF; (*far RET in real address or virtual 8086 mode*)
IF (PE = 1 AND VM = 0) AND instruction = far RET THEN
(*protected mode*)
    IF OperandSize = 32 THEN
        IF third word on stack NOT within stack limits THEN #SS(0);
    ELSE
        IF second word on stack NOT within stack limits THEN
            #SS(0);
    IF return selector RPL < CPL THEN #GP(return selector);
    IF return selector RPL = CPL THEN
        GOTO SAME_PRIVILEGE;
    ELSE
        GOTO LESS_PRIVILEGED;

SAME_PRIVILEGE:
    IF return selector is null THEN #GP(0);
    IF selector index NOT within its descriptor table limits THEN
        #GP(selector);
    IF descriptor AR indicates non-code segment THEN
        #GP(selector);
    IF nonconforming AND
    code segment DPL NOT = CPL THEN
        #GP(selector);
    IF conforming AND code segment DPL > CPL THEN
        #GP(selector);
    IF code segment NOT PRESENT THEN #NP(selector);
    IF top word on stack NOT with stack limits THEN #SS(0);
    IF return_offset NOT within code segment limit THEN
        #GP(0);
    IF OperandSize = 32 THEN
        Load CS:EIP from stack;
        Load CS cache with descriptor;
        ESP := ESP + (8 + immediate offset (*if any*) );
    ELSE (*OperandSize = 16*)
        Load CS:IP from stack;
        Load CS cache with descriptor;
        SP := SP + (4 + immediate offset (*if any*) );

LESS_PRIVILEGED:
    IF OperandSize = 32 AND top (16 + immediate) bytes
    on stack NOT within stack limits THEN
        #SS(0);
```

```
ELSE
    IF top (8 + immediate) bytes on stack
        NOT within stack limits THEN
            #SS(0);
ENDIFELSE; (*check top stack bytes*)
(*Examine return CS selector and associated descriptor: *)
    IF selector is null THEN #GP(0);
    IF selector index NOT within its descriptor table limits
THEN
        #GP(selector);
    Descriptor AR must indicate code segment
        ELSE #GP(selector);
    IF nonconforming AND code segment DPL NOT =
return selector RPL THEN
        #GP(selector);
    IF conforming AND code segment DPL >
return selector RPL THEN
        #GP(selector);
    IF segment NOT PRESENT THEN #NP(selector);
(*END examine return CS selector and descriptor*)
(*Examine return SS selector and associated descriptor: *)
    IF selector is null THEN #GP(0);
    IF selector index NOT within
its descriptor table limits THEN
        #GP(selector);
    IF selector RPL NOT =
RPL of return CS selector THEN
        #GP(selector);
    Descriptor AR must indicate writable data segment
        ELSE #GP(selector);
    IF descriptor DPL NOT = RPL
of return CS selector THEN
        #GP(selector);
    IF segment NOT PRESENT THEN #NP(selector);
(*END examine return SS selector and descriptor*)
    IF return_offset NOT within code segment limit THEN
        #GP(0);
    CPL := RPL of return CS selector;
    IF OperandSize = 32 THEN
        Load CS:EIP from stack;
        (*CS*) RPL := CPL;
        ESP := ESP + (16 + immediate offset (*if any*) );
        Load SS:ESP from stack;
```

```
ELSE (*OperandSize = 16*)
    Load CS:IP from stack;
    (*CS*) RPL := CPL;
    SP := SP + (8 + immediate offset (*if any*) );
    Load SS:SP from stack;
ENDIFELSE; (*OperandSize = 32 or 16*)
Load CS cache with return CS descriptor;
Load SS cache with return SS descriptor;
FOR each of ES, FS, GS, and DS DO
    IF current register setting NOT
    valid for calling routine THEN
        register := null; (*selector and AR := 0*)
        (*To be valid, register setting must satisfy:
        Selector index must be within its
        descriptor table limits;
        Descriptor AR must indicate data
        or readable code segment;
        For data or nonconforming code segment,
        DPL must be >= either CPL or RPL*)
    ENDFOR;
```

## Discussion

RET transfers control to a return address located on the stack. The address is usually placed on the stack by a CALL instruction, and the return is made to the instruction that follows the CALL.

RET's optional numeric operand specifies the number of stack bytes to be released after the return address is popped. The bytes released were input parameters to the procedure called.

An intrasegment (NEAR) RET pops the 4- or 2-byte segment offset address on the stack into (E)IP. The CS register is unchanged. For an intersegment (FAR) RET, the address on the stack is a 4-byte (operand size attribute is 16-bits) or 6-byte (operand size attribute is 32-bits) long pointer, stored on the stack in 8 bytes. RET pops the offset first, followed by the selector.

The assembler distinguishes between NEAR and FAR RETs via the PROC-ENDP context of the instruction. If RET is coded in a NEAR procedure, the near form is used; if RET is in a FAR procedure, the far form is used.

---

In real address mode, `RET` loads `CS` and `IP` directly. In protected mode, an intersegment `RET` causes the processor to check the descriptor addressed by the return selector. The access rights (`AR`) of the descriptor must indicate a code segment of equal or lesser privilege (equal or greater numeric value) than the current privilege level. Returns to a lesser privilege level cause the stack from that level to be restored with parameters removed if an immediate operand is specified.

`RET` can zero the `DS`, `ES`, `FS`, and `GS` segment registers during an interlevel transfer. If these registers refer to segments that cannot be used by the new privilege level, they are set to 0 to prevent unauthorized access.

## Flags Affected

None

## Exceptions by Mode

### Protected

#GP, #NP, or #SS, as described in the Operation section; #PF(fault-code) for a page fault

### Real Address

Interrupt 13 if any part of the operand would be outside the effective address space from 0 to 0FFFFH

### Virtual 8086

Same as Real Address Mode; #PF(fault-code) for a page fault

## SAHF Store AH into Flags

| Opcode | Instruction | Clocks | Description                                 |
|--------|-------------|--------|---------------------------------------------|
| 9E     | SAHF        | 3      | Store AH into flags SF ZF xx AF xx PF xx CF |

### Operation

$(SF) : (ZF) : xx : (AF) : xx : (PF) : xx : (CF) := (AH) ;$

### Discussion

SAHF loads bits 7, 6, 4, 2, and 0 from the AH register into the SF, ZF, AF, PF, and CF flags of the (E) FLAGS register.

### Flags Affected

SF, ZF, AF, PF, and CF

### Exceptions by Mode

#### Protected

None

#### Real Address

None

#### Virtual 8086

None

**SAL/SAR/SHL/SHR** Shift

| Opcode          | Instruction                     | Clocks | Description                                                          |
|-----------------|---------------------------------|--------|----------------------------------------------------------------------|
| D0 /4           | SAL <i>r/m</i> ,1               | 3/7    | Multiply <i>r/m</i> byte by 2, once                                  |
| D2 /4           | SAL <i>r/m</i> ,CL              | 3/7    | Multiply <i>r/m</i> byte by 2, CL times                              |
| C0 /4 <i>ib</i> | SAL <i>r/m</i> , <i>imm</i> 8   | 3/7    | Multiply <i>r/m</i> byte by 2, <i>imm</i> 8 times                    |
| D1 /4           | SAL <i>r/m</i> 16,1             | 3/7    | Multiply <i>r/m</i> word by 2, once                                  |
| D3 /4           | SAL <i>r/m</i> 16,CL            | 3/7    | Multiply <i>r/m</i> word by 2, CL times                              |
| C1 /4 <i>ib</i> | SAL <i>r/m</i> 16, <i>imm</i> 8 | 3/7    | Multiply <i>r/m</i> word by 2, <i>imm</i> 8 times                    |
| D1 /4           | SAL <i>r/m</i> 32,1             | 3/7    | Multiply <i>r/m</i> dword by 2, once                                 |
| D3 /4           | SAL <i>r/m</i> 32,CL            | 3/7    | Multiply <i>r/m</i> dword by 2, CL times                             |
| C1 /4 <i>ib</i> | SAL <i>r/m</i> 32, <i>imm</i> 8 | 3/7    | Multiply <i>r/m</i> dword by 2, <i>imm</i> 8 times                   |
| D0 /7           | SAR <i>r/m</i> ,1               | 3/7    | Signed divide <sup>†</sup> <i>r/m</i> byte by 2, once                |
| D2 /7           | SAR <i>r/m</i> ,CL              | 3/7    | Signed divide <sup>†</sup> <i>r/m</i> byte by 2, CL times            |
| C0 /7 <i>ib</i> | SAR <i>r/m</i> , <i>imm</i> 8   | 3/7    | Signed divide <sup>†</sup> <i>r/m</i> byte by 2, <i>imm</i> 8 times  |
| D1 /7           | SAR <i>r/m</i> 16,1             | 3/7    | Signed divide <sup>†</sup> <i>r/m</i> word by 2, once                |
| D3 /7           | SAR <i>r/m</i> 16,CL            | 3/7    | Signed divide <sup>†</sup> <i>r/m</i> word by 2, CL times            |
| C1 /7 <i>ib</i> | SAR <i>r/m</i> 16, <i>imm</i> 8 | 3/7    | Signed divide <sup>†</sup> <i>r/m</i> word by 2, <i>imm</i> 8 times  |
| D1 /7           | SAR <i>r/m</i> 32,1             | 3/7    | Signed divide <sup>†</sup> <i>r/m</i> dword by 2, once               |
| D3 /7           | SAR <i>r/m</i> 32,CL            | 3/7    | Signed divide <sup>†</sup> <i>r/m</i> dword by 2, CL times           |
| C1 /7 <i>ib</i> | SAR <i>r/m</i> 32, <i>imm</i> 8 | 3/7    | Signed divide <sup>†</sup> <i>r/m</i> dword by 2, <i>imm</i> 8 times |
| D0 /4           | SHL <i>r/m</i> ,1               | 3/7    | Unsigned multiply <i>r/m</i> byte by 2, once                         |
| D2 /4           | SHL <i>r/m</i> ,CL              | 3/7    | Unsigned multiply <i>r/m</i> byte by 2, CL times                     |
| C0 /4 <i>ib</i> | SHL <i>r/m</i> , <i>imm</i> 8   | 3/7    | Unsigned multiply <i>r/m</i> byte by 2, <i>imm</i> 8 times           |
| D1 /4           | SHL <i>r/m</i> 16,1             | 3/7    | Unsigned multiply <i>r/m</i> word by 2, once                         |
| D3 /4           | SHL <i>r/m</i> 16,CL            | 3/7    | Unsigned multiply <i>r/m</i> word by 2, CL times                     |

<sup>†</sup> Rounding is toward negative infinity

| Opcode          | Instruction           | Clocks | Description                                         |
|-----------------|-----------------------|--------|-----------------------------------------------------|
| C1 /4 <i>ib</i> | SHL <i>r/m16,imm8</i> | 3/7    | Unsigned multiply <i>r/m</i> word by 2, imm8 times  |
| D1 /4           | SHL <i>r/m32,1</i>    | 3/7    | Unsigned multiply <i>r/m</i> dword by 2, once       |
| D3 /4           | SHL <i>r/m32,CL</i>   | 3/7    | Unsigned multiply <i>r/m</i> dword by 2, CL times   |
| C1 /4 <i>ib</i> | SHL <i>r/m32,imm8</i> | 3/7    | Unsigned multiply <i>r/m</i> dword by 2, imm8 times |
| D0 /5           | SHR <i>r/m8,1</i>     | 3/7    | Unsigned divide <i>r/m</i> byte by 2, once          |
| D2 /5           | SHR <i>r/m8,CL</i>    | 3/7    | Unsigned divide <i>r/m</i> byte by 2, CL times      |
| C0 /5 <i>ib</i> | SHR <i>r/m8,imm8</i>  | 3/7    | Unsigned divide <i>r/m</i> byte by 2, imm8 times    |
| D1 /5           | SHR <i>r/m16,1</i>    | 3/7    | Unsigned divide <i>r/m</i> word by 2, once          |
| D3 /5           | SHR <i>r/m16,CL</i>   | 3/7    | Unsigned divide <i>r/m</i> word by 2, CL times      |
| C1 /5 <i>ib</i> | SHR <i>r/m16,imm8</i> | 3/7    | Unsigned divide <i>r/m</i> word by 2, imm8 times    |
| D1 /5           | SHR <i>r/m32,1</i>    | 3/7    | Unsigned divide <i>r/m</i> dword by 2, once         |
| D3 /5           | SHR <i>r/m32,CL</i>   | 3/7    | Unsigned divide <i>r/m</i> dword by 2, CL times     |
| C1 /5 <i>ib</i> | SHR <i>r/m32,imm8</i> | 3/7    | Unsigned divide <i>r/m</i> dword by 2, imm8 times   |

## Operation

```
(*Count is the second operand*)
temp := Count;
WHILE (temp NOT = 0) DO
    IF instruction = SAL OR SHL THEN
        CF := high-order bit of r/m;
        r/m := r/m * 2;
    ELSE (*instruction is SAR or SHR*)
        CF := low-order bit of r/m;
    IF instruction = SAR THEN
        r/m := r/m / 2; (*signed divide; round toward -∞*)
    ELSE (*instruction is SHR*)
        r/m := r/m / 2; (*unsigned divide*);
    temp := temp - 1;
ENDWHILE;
IF Count = 1 THEN (*Determine overflow*)
    IF instruction is SAL or SHL THEN
        IF high-order bit of r/m NOT = (CF) THEN
            OF := 1;
```

```

ELSE
    OF := 0;
IF instruction is SAR THEN
    OF := 0;
IF instruction is SHR THEN
    OF := high-order bit of operand;
ELSE (*Count NOT = 1*)      OF := UNDEFINED;

```

## Discussion

SAL/SAR/SHL/SHR shift the bits of the register or memory operand. SAL/SHL shift the bits upward, copying the high-order bit into the carry flag and clearing the low-order bit (0). SAR/SHR shift the bits downward, copying the low-order bit into the carry flag; the effect is to divide the operand by 2. SAR performs a signed divide by 2 with rounding toward negative infinity (not like IDIV); the high-order bit remains the same. SHR performs an unsigned divide; the high-order bit is cleared.

The second operand is a shift count in the range 1..31; the operand is either an immediate number or the contents of CL. For a shift count value greater than 31, the processor uses only its low-order 5-bits. (The 8086 uses all 8-bits of the shift count.)

The overflow flag is defined only if the second operand is 1; otherwise, it is undefined. SAL/SHL clear OF (to 0) if the high bit of the answer is the same as the result of the carry flag (i.e., the top two bits of the original operand are the same); OF is set to 1 if they are different. SAR clears OF for all single shifts. SHR sets OF to the high-order bit of the original operand.

## Flags Affected

CF and OF for single shifts as indicated in the Discussion section; OF is undefined for shift counts greater than 1; ZF, PF, and SF as described in Appendix A

## Exceptions by Mode

### Protected

#GP(0) if the result is in a nonwritable segment; #GP(0) for an illegal memory operand effective address in the CS, DS, ES, FS, or GS segments; #SS(0) for an illegal address in the SS segment; #PF(fault-code) for a page fault

### Real Address

Interrupt 13 if any part of the operand would lie outside the effective address space from 0 to 0FFFFH

### Virtual 8086

Same as Real Address Mode; #PF(fault-code) for a page fault

**SBB** Integer Subtraction with Borrow

| Opcode          | Instruction            | Clocks | Description                                                             |
|-----------------|------------------------|--------|-------------------------------------------------------------------------|
| 1C <i>ib</i>    | SBB AL, <i>imm8</i>    | 2      | Subtract with borrow immediate byte from AL                             |
| 1D <i>iw</i>    | SBB AX, <i>imm16</i>   | 2      | Subtract with borrow immediate word from AX                             |
| 1D <i>id</i>    | SBB EAX, <i>imm32</i>  | 2      | Subtract with borrow immediate dword from EAX                           |
| 80 /3 <i>ib</i> | SBB <i>r/m8,imm8</i>   | 2/7    | Subtract with borrow immediate byte from <i>r/m</i> byte                |
| 81 /3 <i>iw</i> | SBB <i>r/m16,imm16</i> | 2/7    | Subtract with borrow immediate word from <i>r/m</i> word                |
| 81 /3 <i>id</i> | SBB <i>r/m32,imm32</i> | 2/7    | Subtract with borrow immediate dword from <i>r/m</i> dword              |
| 83 /3 <i>ib</i> | SBB <i>r/m16,imm8</i>  | 2/7    | Subtract with borrow sign-extended immediate byte from <i>r/m</i> word  |
| 83 /3 <i>ib</i> | SBB <i>r/m32,imm8</i>  | 2/7    | Subtract with borrow sign-extended immediate byte from <i>r/m</i> dword |
| 18 / <i>r</i>   | SBB <i>r/m8,r8</i>     | 2/6    | Subtract with borrow byte register from <i>r/m</i> byte                 |
| 19 / <i>r</i>   | SBB <i>r/m16,r16</i>   | 2/6    | Subtract with borrow word register from <i>r/m</i> word                 |
| 19 / <i>r</i>   | SBB <i>r/m32,r32</i>   | 2/6    | Subtract with borrow dword register from <i>r/m</i> dword               |
| 1A / <i>r</i>   | SBB <i>r8,r/m8</i>     | 2/7    | Subtract with borrow <i>r/m</i> byte from byte register                 |
| 1B / <i>r</i>   | SBB <i>r16,r/m16</i>   | 2/7    | Subtract with borrow <i>r/m</i> word from word register                 |
| 1B / <i>r</i>   | SBB <i>r32,r/m32</i>   | 2/7    | Subtract with borrow <i>r/m</i> dword from dword register               |

**Operation**

```

IF Src is byte AND Dest is word OR dword THEN
    Dest = Dest - (SignExtend(Src) + CF);
ELSE
    Dest := Dest - (Src + CF);

```

## Discussion

SBB adds the second operand to the carry flag (CF) and subtracts the result from the first operand. Then SBB copies the result to the first operand, and sets the flags accordingly.

When SBB subtracts an immediate byte value from a word or dword operand, it sign-extends the immediate value before the subtraction.

## Flags Affected

OF, SF, ZF, AF, PF, and CF as described in Appendix A

## Exceptions by Mode

### Protected

#GP(0) if the result is in a nonwritable segment; #GP(0) for an illegal memory operand effective address in the CS, DS, ES, FS, or GS segments; #SS(0) for an illegal address in the SS segment; #PF(fault-code) for a page fault

### Real Address

Interrupt 13 if any part of the operand would lie outside the effective address space from 0 to 0FFFFH

### Virtual 8086

Same as Real Address Mode; #PF(fault-code) for a page fault

**SCAS/SCASB/SCASW/SCASD** Compare String Data

| Opcode | Instruction     | Clocks | Description                                    |
|--------|-----------------|--------|------------------------------------------------|
| AE     | SCAS <i>m8</i>  | 7      | Compare bytes AL - ES:[ (E)DI], update (E)DI   |
| AF     | SCAS <i>m16</i> | 7      | Compare words AX - ES:[ (E)DI], update (E)DI   |
| AF     | SCAS <i>m32</i> | 7      | Compare dwords EAX - ES:[ (E)DI], update (E)DI |
| AE     | SCASB           | 7      | Compare bytes AL - ES:[ (E)DI], update (E)DI   |
| AF     | SCASW           | 7      | Compare words AX - ES:[ (E)DI], update (E)DI   |
| AF     | SCASD           | 7      | Compare dwords EAX - ES:[ (E)DI], update (E)DI |

**Operation**

```

IF AddressSize = 16 THEN
    Use DI for DestIndex;
ELSE (*AddressSize = 32*)
    Use EDI for DestIndex;
IF byte type of instruction THEN
    AL - [DestIndex]; (*compare byte in AL with destination*)
    IF DF = 0 THEN IncDec := 1 ELSE IncDec := -1;
ELSE
    IF OperandSize = 16 THEN
        (*compare word in AX with destination*)
        AX - [DestIndex];
        IF DF = 0 THEN IncDec := 2 ELSE IncDec := -2;
    ELSE (*OperandSize = 32*)
        (*compare dword in EAX with destination*)
        EAX - [DestIndex];
        IF DF = 0 THEN IncDec := 4 ELSE IncDec := -4;
    DestIndex := DestIndex + IncDec;

```

### Discussion

SCAS subtracts the memory byte, word, or dword at the destination register from the AL, AX or EAX register. SCAS discards the result; only the flags are set. The operand must be addressable from the ES segment; no segment override is possible.

If the address size attribute for this instruction is 16-bits, DI is used as the destination index register; otherwise, the address size attribute is 32-bits and EDI is used.

The address of memory data is determined solely by the contents of the destination index register, not by the SCAS operand. Load the correct index value into (E)DI before executing SCAS.

The SCAS operand validates ES segment addressability and determines the data type. After the comparison is made, the destination register is automatically updated. If the direction flag is 0 (CLD was executed), the destination index register is incremented; if the direction flag is 1 (STD was executed), it is decremented. SCAS increments or decrements the destination by 1 if it compares bytes, by 2 if it compares words, or by 4 if it compares dwords.

SCASB, SCASW, and SCASD are synonyms for the byte, word and dword SCAS instructions. They are simpler, but they provide no type or segment checking.

SCAS can be preceded by the REPE or REPNE prefix for a block search of (E)CX bytes, words, or dwords. See the REP prefix for details of this operation.

### Flags Affected

OF, SF, ZF, AF, PF, and CF as described in Appendix A

### Exceptions by Mode

#### Protected

#GP(0) for an illegal memory operand effective address in the CS, DS, ES, FS, or GS segments; #SS(0) for an illegal address in the SS segment; #PF(fault-code) for a page fault

#### Real Address

Interrupt 13 if any part of the operand would lie outside the effective address space from 0 to 0FFFFH

#### Virtual 8086

Same as Real Address Mode; #PF(fault-code) for a page fault

**SETcc** Byte Set on Condition

| Opcode | Instruction        | Clocks | Description                                         |
|--------|--------------------|--------|-----------------------------------------------------|
| 0F 97  | SETA <i>r/m8</i>   | 4/5    | Set byte if above (CF=0 and ZF=0)                   |
| 0F 93  | SETAE <i>r/m8</i>  | 4/5    | Set byte if above or equal (CF=0)                   |
| 0F 92  | SETB <i>r/m8</i>   | 4/5    | Set byte if below (CF=1)                            |
| 0F 96  | SETBE <i>r/m8</i>  | 4/5    | Set byte if below or equal (CF=1 or ZF=1)           |
| 0F 92  | SETC <i>r/m8</i>   | 4/5    | Set if carry (CF=1)                                 |
| 0F 94  | SETE <i>r/m8</i>   | 4/5    | Set byte if equal (ZF=1)                            |
| 0F 9F  | SETG <i>r/m8</i>   | 4/5    | Set byte if greater (ZF=0 and SF=OF)                |
| 0F 9D  | SETGE <i>r/m8</i>  | 4/5    | Set byte if greater or equal (SF=OF)                |
| 0F 9C  | SETL <i>r/m8</i>   | 4/5    | Set byte if less (SF NOT = OF)                      |
| 0F 9E  | SETLE <i>r/m8</i>  | 4/5    | Set byte if less or equal (ZF=1 or SF NOT = OF)     |
| 0F 96  | SETNA <i>r/m8</i>  | 4/5    | Set byte if not above (CF=1 or ZF = 1)              |
| 0F 92  | SETNAE <i>r/m8</i> | 4/5    | Set byte if not above and not equal (CF=1)          |
| 0F 93  | SETNB <i>r/m8</i>  | 4/5    | Set byte if not below (CF=0)                        |
| 0F 97  | SETNBE <i>r/m8</i> | 4/5    | Set byte if not below and not equal (CF=0 and ZF=0) |
| 0F 93  | SETNC <i>r/m8</i>  | 4/5    | Set byte if not carry (CF=0)                        |
| 0F 95  | SETNE <i>r/m8</i>  | 4/5    | Set byte if not equal (ZF=0)                        |
| 0F 9E  | SETNG <i>r/m8</i>  | 4/5    | Set byte if not greater (ZF=1 or SF NOT = OF)       |
| 0F 9C  | SETNGE <i>r/m8</i> | 4/5    | Set byte if not greater and not equal (SF NOT = OF) |
| 0F 9D  | SETNL <i>r/m8</i>  | 4/5    | Set byte if not less (SF=OF)                        |
| 0F 9F  | SETNLE <i>r/m8</i> | 4/5    | Set byte if not less and not equal (ZF=1 and SF=OF) |
| 0F 91  | SETNO <i>r/m8</i>  | 4/5    | Set byte if not overflow (OF=0)                     |
| 0F 9B  | SETNP <i>r/m8</i>  | 4/5    | Set byte if not parity (PF=0)                       |
| 0F 99  | SETNS <i>r/m8</i>  | 4/5    | Set byte if not sign (SF=0)                         |
| 0F 95  | SETNZ <i>r/m8</i>  | 4/5    | Set byte if not zero (ZF=0)                         |
| 0F 90  | SETO <i>r/m8</i>   | 4/5    | Set byte if overflow (OF=1)                         |
| 0F 9A  | SETP <i>r/m8</i>   | 4/5    | Set byte if parity (PF=1)                           |

| Opcode | Instruction       | Clocks | Description                    |
|--------|-------------------|--------|--------------------------------|
| 0F 9A  | SETPE <i>r/m8</i> | 4/5    | Set byte if parity even (PF=1) |
| 0F 9B  | SETPO <i>r/m8</i> | 4/5    | Set byte if parity odd (PF=0)  |
| 0F 98  | SETS <i>r/m8</i>  | 4/5    | Set byte if sign (SF=1)        |
| 0F 94  | SETZ <i>r/m8</i>  | 4/5    | Set byte if zero (ZF=1)        |

### Operation

```
IF condition THEN
    r/m8 := 1;
ELSE
    r/m8 := 0;
```

### Discussion

SETcc stores a byte value at the destination specified by the memory effective address or register. SETcc stores a 1 if the condition is met; it stores 0 if the condition is not met.

### Flags Affected

None

### Exceptions by Mode

#### Protected

#GP(0) if the result is in a non-writable segment; #GP(0) for an illegal memory operand effective address in the CS, DS, ES, FS, or GS segments; #SS(0) for an illegal address in the SS segment; #PF(fault-code) for a page fault

#### Real Address

Interrupt 13 if any part of the operand would lie outside the effective address space from 0 to 0FFFFH

#### Virtual 8086

Same as Real Address Mode; #PF(fault-code) for a page fault

## SGDT/SIDT Store Global/Interrupt Descriptor Table Register

| Opcode   | Instruction   | Clocks | Description            |
|----------|---------------|--------|------------------------|
| 0F 01 /0 | SGDT <i>m</i> | 9      | Store GDTR to <i>m</i> |
| 0F 01 /1 | SIDT <i>m</i> | 9      | Store IDTR to <i>m</i> |

### Operation

Dest := 48-bit BASE/LIMIT register contents;

### Discussion

SGDT/SIDT copies the contents of the descriptor table register to the 6 bytes of memory specified by the operand. SGDT/SIDT assign the limit field of the register to the low-order word at the effective address.

If the operand size attribute is 32-bits, SGDT/SIDT assign the 32-bit base field of the register to the next 4 bytes. If the register was loaded with operand size attribute of 16-bits, these instructions assign the base field of the register to the next 3 memory bytes and zero to the high-order byte.

The 16-bit forms of the SGDT/SIDT instructions are compatible with the 286 processor SGDT/SIDT if the value in the high-order 8-bits is not referenced.

### Flags Affected

None

### Exceptions by Mode

#### Protected

#UD if the destination operand is a register; #GP(0) if the destination is in a nonwritable segment; #GP(0) for an illegal memory operand effective address in the CS, DS, ES, FS, or GS segments; #SS(0) for an illegal address in the SS segment; #PF(fault-code) for a page fault

### Real Address

Interrupt 6 if the destination operand is a register; Interrupt 13 if any part of the operand would lie outside the effective address space from 0 to 0FFFFH

### Virtual 8086

Same as Real Address Mode; #PF(fault-code) for a page fault

## SGDTW/SGDTD/SIDTW/SIDTD

Store Global/Interrupt Descriptor Table Register with WORD/DWORD Operand

| Opcode   | Instruction      | Clocks | Description               |
|----------|------------------|--------|---------------------------|
| 0F 01 /0 | SGDTW <i>m16</i> | 9      | Load <i>m16</i> into GDTR |
| 0F 01 /0 | SGDTD <i>m32</i> | 9      | Load <i>m32</i> into GDTR |
| 0F 01 /1 | SIDTW <i>m16</i> | 9      | Load <i>m16</i> into IDTR |
| 0F 01 /1 | SIDTD <i>m32</i> | 9      | Load <i>m32</i> into IDTR |

### Operation

DEST := 48-bit BASE/LIMIT register contents;

### Discussion

The SGDTW, SGDTD, SIDTW, and SIDTD instructions are variants of the SGDT and SIDT instructions. They copy the contents of the descriptor table register to the 6 bytes of memory specified by the operand.

These variants allow the 16-bit or 32-bit form of the instructions to be used without hard-coding address and operand prefixes to override the USE attribute currently in effect.

The variants automatically generate any operand or address prefixes that are necessary as follows:

| Instruction | USE16          | USE16          | USE32          | USE32          |
|-------------|----------------|----------------|----------------|----------------|
|             | Operand Prefix | Address Prefix | Operand Prefix | Address Prefix |
| SGDTW/SIDTW | NO             | NO             | YES            | YES            |
| SGDTD/SIDTD | YES            | YES            | NO             | NO             |

See also: SGDT/SIDT instructions for further discussion, flags affected, and exceptions, in this chapter

**SHLD** Double Precision Shift Left

| Opcode      | Instruction                            | Clocks | Description                                                        |
|-------------|----------------------------------------|--------|--------------------------------------------------------------------|
| 0F A4 /r ib | SHLD <i>r/m16</i> ,<br><i>r16,imm8</i> | 3/7    | <i>r/m16</i> gets SHL of <i>r/m16</i> concatenated with <i>r16</i> |
| 0F A4 /r ib | SHLD <i>r/m32</i> ,<br><i>r32,imm8</i> | 3/7    | <i>r/m32</i> gets SHL of <i>r/m32</i> concatenated with <i>r32</i> |
| 0F A5 /r    | SHLD <i>r/m16</i> ,<br><i>r16,CL</i>   | 3/7    | <i>r/m16</i> gets SHL of <i>r/m16</i> concatenated with <i>r16</i> |
| 0F A5 /r    | SHLD <i>r/m32</i> ,<br><i>r32,CL</i>   | 3/7    | <i>r/m32</i> gets SHL of <i>r/m32</i> concatenated with <i>r32</i> |

**Operation**

(\*Count is an unsigned integer corresponding to the last operand of the instruction, either an immediate byte or the byte in register CL\*)  
 ShiftAmt := Count MOD 32; (\*Count = third operand\*)

IF ShiftAmt = 0 THEN

    NOP;

ELSE

    IF *ShiftAmt* >= *OperandSize* THEN (\*bad parameters\*)

*r/m* := UNDEFINED;

        Flags := UNDEFINED; (\*CF, OF, SF, ZF, AF, and PF\*)

    ELSE (\*do the shift; allow overlapped operands\*)

*inBits* := *r16/32*; (\*second operand\*)

        Base := Dest;

        CF := BIT[Base, (*OperandSize* - *ShiftAmt*) ];

        (\*last bit shifted out on exit\*)

        FOR *i* := (*OperandSize* - 1) DOWNTO *ShiftAmt* DO

            BIT[Base, *i*] := BIT[Base, *i* - *ShiftAmt*];

        ENDFOR;

        FOR *i* := (*ShiftAmt* - 1) DOWNTO 0 DO

            BIT[Base, *i*] := BIT[*inBits*, *i* - *ShiftAmt* + *OperandSize*];

        ENDFOR;

        (\*SF, ZF, PF, OF are set according to the result value\*)

        Set SF, ZF, PF, (*r/m*);

        IF BIT[Base, *OperandSize* - 1] NOT = CF THEN

            OF := 1;

        ELSE

            OF := 0;

        AF := UNDEFINED;

---

## Discussion

SHLD shifts the r/m first operand to the left as many bits as specified by the count (third operand) modulo 32. The second operand (r16 or r32) provides the bits to shift in from the right, starting with the bit (OperandSize - ShiftAmount). The result is stored back into the r/m operand. The second operand is unchanged.

The count is either an immediate byte or the contents of the CL register. Its value is taken modulo 32 to yield a shift amount in the range 0..31. The shift amount must be less than the operand size, or SHLD does nothing.

SHLD sets SF, ZF and PF according to the value of the result. It sets CF to the value of the last bit shifted out and OF to 1 if this bit caused an overflow. AF is undefined.

## Flags Affected

OF, SF, ZF, PF, and CF as described in the Discussion section; AF is undefined

## Exceptions by Mode

### Protected

#GP(0) if the result is in a nonwritable segment; #GP(0) for an illegal memory operand effective address in the CS, DS, ES, FS, or GS segments; #SS(0) for an illegal address in the SS segment; #PF(fault-code) for a page fault

### Real Address

Interrupt 13 if any part of the operand would lie outside the effective address space from 0 to 0FFFFH

### Virtual 8086

Same as Real Address Mode; #PF(fault-code) for a page fault

**SHRD** Double Precision Shift Right

| Opcode      | Instruction          | Clocks | Description                                      |
|-------------|----------------------|--------|--------------------------------------------------|
| 0F AC /r ib | SHRD r/m16, r16,imm8 | 3/7    | r/m16 gets SHR of r16 concatenated with r16,imm8 |
| 0F AC /r ib | SHRD r/m32, r32,imm8 | 3/7    | r/m32 gets SHR of r32 concatenated with r32,imm8 |
| 0F AD /r    | SHRD r/m16, r16,CL   | 3/7    | r/m16 gets SHR of r16 concatenated with r16,CL   |
| 0F AD /r    | SHRD r/m32, r32,CL   | 3/7    | r/m32 gets SHR of r32 concatenated with r32,CL   |

**Operation**

```

(*Count is an unsigned integer corresponding to the last operand of
the instruction, either an immediate byte or the byte in register CL*)
ShiftAmt := Count MOD 32;
IF ShiftAmt = 0 THEN
    NOP;
ELSE
    IF ShiftAmt >= OperandSize THEN (*bad parameters*)
        r/m := UNDEFINED;
        Flags := UNDEFINED; (*CF,OF,SF,ZF,AF, and PF*)
    ELSE (*do the shift; allow overlapped operands*)
        inBits := r16/32; (*second operand*)
        Base := Dest;
        CF := BIT[Base, ShiftAmt - 1];
        (*last bit shifted out on exit*)
        FOR i := 0 TO (OperandSize - 1 - ShiftAmt) DO
            BIT[Base, i] := BIT[Base, i + ShiftAmt];
        ENDFOR;
        FOR i := (OperandSize - ShiftAmt) TO (OperandSize - 1) DO
            BIT[Base,i] := BIT[inBits, i + ShiftAmt - OperandSize];
        ENDFOR;
        (*SF, ZF, PF, and OF are set according to the result value*)
        Set SF, ZF, PF (r/m);
    
```

```

IF BIT[Base, OperandSize - 1]
NOT = BIT[Base, OperandSize - 2] THEN
    OF := 1;
ELSE
    OF := 0;
AF := UNDEFINED;

```

## Discussion

SHRD shifts the r/m first operand to the right as many bits as specified by the count (third operand) modulo 32. The second operand (r16 or r32) provides the bits to shift in from the left, starting with bit 0. The result is stored back into the r/m operand. The second operand is unchanged.

The count is either an immediate byte or the contents of the CL register. Its value is taken modulo 32 to yield a shift amount in the range 0..31. The shift amount must be less than the operand size, or SHRD does nothing.

SHRD sets SF, ZF and PF according to the value of the result. It sets CF to the value of the last bit shifted out and sets OF if the 2 most significant bits differ. AF is undefined.

## Flags Affected

SF, ZF, PF, CF and OF as described in the Discussion section; AF is undefined

## Exceptions by Mode

### Protected

#GP(0) if the result is in a nonwritable segment; #GP(0) for an illegal memory operand effective address in the CS, DS, ES, FS, or GS segments; #SS(0) for an illegal address in the SS segment; #PF(fault-code) for a page fault

### Real Address

Interrupt 13 if any part of the operand would lie outside the effective address space from 0 to 0FFFFH

### Virtual 8086

Same as Real Address Mode; #PF(fault-code) for a page fault

## SLDT Store Local Descriptor Table Register

| Opcode   | Instruction       | Clocks        | Description                |
|----------|-------------------|---------------|----------------------------|
| 0F 00 /0 | SLDT <i>r/m16</i> | <i>pm=2/2</i> | Store LDTR to <i>r/m16</i> |

### Operation

*r/m16* := LDTR;

### Discussion

SLDT stores the Local Descriptor Table Register (LDTR) in the operand, a 2-byte register or memory location. The operand size attribute has no effect on SLDT's operation.

LDTR is a selector that points to the LDT descriptor in the Global Descriptor Table.

### Flags Affected

None

### Exceptions by Mode

#### Protected

#GP(0) if the result is in a nonwritable segment; #GP(0) for an illegal memory operand effective address in the CS, DS, ES, FS, or GS segments; #SS(0) for an illegal address in the SS segment; #PF(fault-code) for a page fault

#### Real Address

Interrupt 6; SLDT is not recognized in Real Address Mode

#### Virtual 8086

Same as Real Address Mode

**SMSW** Store Machine Status Word

| Opcode   | Instruction       | Clocks              | Description                               |
|----------|-------------------|---------------------|-------------------------------------------|
| 0F 01 /4 | SMSW <i>r/m16</i> | 2/3, <i>pm</i> =2/2 | Store machine status word to <i>r/m16</i> |

**Operation**

*r/m16* := MSW;

**Discussion**

SMSW stores the machine status word of CR0 in the 2-byte register or memory location specified by its operand.

**Flags Affected**

None

**Exceptions by Mode****Protected**

#GP(0) if the result is in a nonwritable segment; #GP(0) for an illegal memory operand effective address in the CS, DS, ES, FS, or GS segments; #SS(0) for an illegal address in the SS segment; #PF(fault-code) for a page fault

**Real Address**

Interrupt 13 if any part of the operand would lie outside the effective address space from 0 to 0FFFFH

**Virtual 8086**

Same as Real Address Mode; #PF(fault-code) for a page fault

# STC

---

## STC Set Carry Flag

| Opcode | Instruction | Clocks | Description    |
|--------|-------------|--------|----------------|
| F9     | STC         | 2      | Set carry flag |

### Operation

CF := 1;

### Discussion

STC sets the carry flag to 1.

### Flags Affected

CF = 1

### Exceptions by Mode

#### Protected

None

#### Real Address

None

#### Virtual 8086

None

**STD** Set Direction Flag

| Opcode | Instruction | Clocks | Description                                        |
|--------|-------------|--------|----------------------------------------------------|
| FD     | STD         | 2      | Set direction flag so (E)SI and/or (E)DI decrement |

**Operation**

```
DF := 1;
```

**Discussion**

STD sets the direction flag to 1, causing all subsequent string operations to decrement the index registers, (E)SI and/or (E)DI.

**Flags Affected**

```
DF = 1
```

**Exceptions by Mode****Protected**

```
None
```

**Real Address**

```
None
```

**Virtual 8086**

```
None
```

## STI Set Interrupt Flag

| Opcode | Instruction | Clocks | Description                                                               |
|--------|-------------|--------|---------------------------------------------------------------------------|
| FB     | STI         | 3      | Set interrupt flag; interrupts enabled at the end of the next instruction |

### Operation

```
IF CPL > IOPL THEN
    #GP(0);
ELSE
    IF (*interrupt flag*) := 1;
```

### Discussion

STI sets the interrupt flag in the (E)FLAGS register. The processor then responds to external interrupts after executing the next instruction (if this instruction allows the interrupt flag to remain enabled). If external interrupts are disabled:

- STI, CLI has no effect except that it uses clocks. CLI clears the interrupt flag set by STI; external interrupts are not recognized after this instruction sequence.
- STI, RET (at the end of a subroutine) allows RET to execute before external interrupts are recognized.

### Flags Affected

IF = 1

### Exceptions by Mode

#### Protected

#GP(0) if the current privilege level (CPL) is greater (has less privilege) than IOPL

#### Real Address

None

#### Virtual 8086

#GP(0) to allow emulation

## STOS/STOSB/STOSW/STOSD Store String Data

| Opcode | Instruction     | Clocks | Description                                  |
|--------|-----------------|--------|----------------------------------------------|
| AA     | STOS <i>m8</i>  | 4      | Store AL in byte ES:[ (E)DI], update (E)DI   |
| AB     | STOS <i>m16</i> | 4      | Store AX in word ES:[ (E)DI], update (E)DI   |
| AB     | STOS <i>m32</i> | 4      | Store EAX in dword ES:[ (E)DI], update (E)DI |
| AA     | STOSB           | 4      | Store AL in byte ES:[ (E)DI], update (E)DI   |
| AB     | STOSW           | 4      | Store AX in word ES:[ (E)DI], update (E)DI   |
| AB     | STOSD           | 4      | Store EAX in dword ES:[ (E)DI], update (E)DI |

### Operation

```

IF AddressSize = 16 THEN
    Use ES:DI for DestReg;
ELSE (*AddressSize = 32*)
    Use ES:EDI for DestReg;
IF byte type of instruction THEN
    (ES:DestReg) := AL;
    IF DF = 0 THEN IncDec := 1 ELSE IncDec := -1;
ELSE (*word or dword instruction*)
    IF OperandSize = 16 THEN
        (ES:DestReg) := AX;
        IF DF = 0 THEN IncDec := 2 ELSE IncDec := -2;
    ELSE (*OperandSize = 32*)
        (ES:DestReg) := EAX;
        IF DF = 0 THEN IncDec := 4 ELSE IncDec := -4;
DestReg := DestReg + IncDec;

```

### Discussion

STOS transfers the contents of AL, AX, or EAX register to the memory byte, word or dword accessed by ES:(E)DI. The destination register is DI for an address size attribute of 16-bits or EDI for an address size attribute of 32-bits. The destination operand must be addressable from the ES register. No segment override is possible.

The address of the destination is determined by the contents of (E)DI, not by the STOS operand. This operand is used only to validate ES segment addressability and to determine the data type. Load the correct index value into (E)DI before executing STOS.

## STOS/STOSB/STOSW/STOSD

---

STOSB, STOSW, and STOSD are synonyms for the byte, word, and dword STOS instructions. They are simpler, but they provide no type or segment checking.

After the transfer is made, (E)DI is automatically updated. If the direction flag is 0 (CLD was executed), the destination register is incremented; if the direction flag is 1 (STD was executed), (E)DI is decremented. (E)DI is incremented or decremented by 1 if a byte is stored, by 2 if a word is stored, or by 4 if a dword is stored.

STOS can be preceded by the REP prefix for a block fill of (E)CX bytes, words, or dwords. See the REP reference for details of this operation.

### Flags Affected

None

### Exceptions by Mode

#### Protected

#GP(0) if the result is in a nonwritable segment; #GP(0) for an illegal memory operand effective address in the CS, DS, ES, FS, or GS segments; #SS(0) for an illegal address in the SS segment; #PF(fault-code) for a page fault

#### Real Address

Interrupt 13 if any part of the operand would lie outside the effective address space from 0 to 0FFFFH

#### Virtual 8086

Same as Real Address Mode; #PF(fault-code) for a page fault

**STR** Store Task Register

| Opcode   | Instruction      | Clocks          | Description                              |
|----------|------------------|-----------------|------------------------------------------|
| 0F 00 /1 | STR <i>r/m16</i> | <i>pm=23/27</i> | Store task register into <i>r/m</i> word |

**Operation**

```
r/m16 := task register;
```

**Discussion**

STR copies the contents of the task register into the 2-byte register or memory location specified by the operand.

The operand size attribute has no effect on this instruction.

**Flags Affected**

None

**Exceptions by Mode****Protected**

#GP(0) if the result is in a nonwritable segment; #GP(0) for an illegal memory operand effective address in the CS, DS, ES, FS, or GS segments; #SS(0) for an illegal address in the SS segment; #PF(fault-code) for a page fault

**Real Address**

Interrupt 6; STR is not recognized in Real Address Mode

**Virtual 8086**

Same as Real Address Mode

**SUB** Integer Subtraction

| Opcode          | Instruction                     | Clocks | Description                                                                |
|-----------------|---------------------------------|--------|----------------------------------------------------------------------------|
| 2C <i>ib</i>    | SUB AL, <i>imm8</i>             | 2      | Subtract immediate byte from AL                                            |
| 2D <i>iw</i>    | SUB AX, <i>imm16</i>            | 2      | Subtract immediate word from AX                                            |
| 2D <i>id</i>    | SUB EAX, <i>imm32</i>           | 2      | Subtract immediate dword from EAX                                          |
| 80 /5 <i>ib</i> | SUB <i>r/m8</i> , <i>imm8</i>   | 2/7    | Subtract immediate byte from <i>r/m</i> byte                               |
| 81 /5 <i>iw</i> | SUB <i>r/m16</i> , <i>imm16</i> | 2/7    | Subtract immediate word from <i>r/m</i> word                               |
| 81 /5 <i>id</i> | SUB <i>r/m32</i> , <i>imm32</i> | 2/7    | Subtract immediate dword from <i>r/m</i> dword                             |
| 83 /5 <i>ib</i> | SUB <i>r/m16</i> , <i>imm8</i>  | 2/7    | Subtract sign-extended immediate byte from <i>r/m</i> word                 |
| 83 /5 <i>ib</i> | SUB <i>r/m32</i> , <i>imm8</i>  | 2/7    | Subtract sign-extended immediate byte from <i>r/m</i> dword                |
| 28 / <i>r</i>   | SUB <i>r/m8</i> , <i>r8</i>     | 2/6    | Subtract byte register from <i>r/m</i> byte                                |
| 29 / <i>r</i>   | SUB <i>r/m16</i> , <i>r16</i>   | 2/6    | Subtract word register from <i>r/m</i> word register from <i>r/m</i> dword |
| 2A / <i>r</i>   | SUB <i>r8</i> , <i>r/m8</i>     | 2/7    | Subtract <i>r/m</i> byte from byte register                                |
| 2B / <i>r</i>   | SUB <i>r16</i> , <i>r/m16</i>   | 2/7    | Subtract <i>r/m</i> word from word register                                |
| 2B / <i>r</i>   | SUB <i>r32</i> , <i>r/m32</i>   | 2/7    | Subtract <i>r/m</i> dword from dword register                              |

**Operation**

```
IF Src is byte AND Dest is word OR dword THEN
    SignExtend(Src);
Dest := Dest - Src;
```

**Discussion**

SUB subtracts the second operand from the first operand, assigns the result to the first operand (Dest), and sets the flags accordingly.

When an immediate byte value is subtracted from a word or dword operand, the immediate value is first sign-extended to the size of the destination operand.

**Flags Affected**

OF, SF, ZF, AF, PF, and CF as described in Appendix A

## Exceptions by Mode

### Protected

#GP(0) if the result is in a nonwritable segment; #GP(0) for an illegal memory operand effective address in the CS, DS, ES, FS, or GS segments; #SS(0) for an illegal address in the SS segment; #PF(fault-code) for a page fault

### Real Address

Interrupt 13 if any part of the operand would lie outside the effective address space from 0 to 0FFFFH

### Virtual 8086

Same as Real Address Mode; #PF(fault-code) for a page fault

## TEST Logical Compare

| Opcode          | Instruction                      | Clocks | Description                               |
|-----------------|----------------------------------|--------|-------------------------------------------|
| A8 <i>ib</i>    | TEST AL, <i>imm8</i>             | 2      | AND immediate byte with AL                |
| A9 <i>iw</i>    | TEST AX, <i>imm16</i>            | 2      | AND immediate word with AX                |
| A9 <i>id</i>    | TEST EAX, <i>imm32</i>           | 2      | AND immediate dword with EAX              |
| F6 /0 <i>ib</i> | TEST <i>r/m8</i> , <i>imm8</i>   | 2/5    | AND immediate byte with <i>r/m</i> byte   |
| F7 /0 <i>iw</i> | TEST <i>r/m16</i> , <i>imm16</i> | 2/5    | AND immediate word with <i>r/m</i> word   |
| F7 /0 <i>id</i> | TEST <i>r/m32</i> , <i>imm32</i> | 2/5    | AND immediate dword with <i>r/m</i> dword |
| 84 / <i>r</i>   | TEST <i>r/m8</i> , <i>r8</i>     | 2/5    | AND byte register with <i>r/m</i> byte    |
| 85 / <i>r</i>   | TEST <i>r/m16</i> , <i>r16</i>   | 2/5    | AND word register with <i>r/m</i> word    |
| 85 / <i>r</i>   | TEST <i>r/m32</i> , <i>r32</i>   | 2/5    | AND dword register with <i>r/m</i> dword  |
| 84 / <i>r</i>   | TEST <i>r8</i> , <i>r/m8</i>     | 2/5    | AND <i>r/m</i> byte with byte register    |
| 85 / <i>r</i>   | TEST <i>r16</i> , <i>r/m16</i>   | 2/5    | AND <i>r/m</i> word with word register    |
| 85 / <i>r</i>   | TEST <i>r32</i> , <i>r/m32</i>   | 2/5    | AND <i>r/m</i> dword with dword register  |

## Operation

```

Dest AND RightSrc;
(*Set SF, ZF, and PF according to AND result*)
CF := 0;
OF := 0;

```

## Discussion

TEST does a bit-wise logical AND of its two operands. A corresponding AND result bit is 1 if both operands' corresponding bits are 1; otherwise, the result bit is 0.

TEST discards the AND result; its purpose is to assign values to the ZF, SF, and PF flags, and to clear CF and OF. For example:

```

TEST AL,1    ; AND AL bottom bit with 1;
              ; assign to ZF, SF, PF
JNZ FINISH   ; jump to FINISH if AL's
              ; LSB is set

```

See the `Jcc` and `SETcc` instructions for more information about the SF, ZF, and PF tests. TEST clears CF and OF.

## Flags Affected

OF = 0, CF = 0; SF, ZF, and PF as described in Appendix A

## Exceptions by Mode

### Protected

#GP(0) for an illegal memory operand effective address in the CS, DS, ES, FS, or GS segments; #SS(0) for an illegal address in the SS segment; #PF(fault-code) for a page fault

### Real Address

Interrupt 13 if any part of the operand would lie outside the effective address space from 0 to 0FFFFH

### Virtual 8086

Same as Real Address Mode; #PF(fault-code) for a page fault

### VERR/VERW Verify a Segment for Reading or Writing

| Opcode   | Instruction       | Clocks           | Description                                                  |
|----------|-------------------|------------------|--------------------------------------------------------------|
| 0F 00 /4 | VERR <i>r/m16</i> | <i>pm</i> =10/11 | Set ZF=1 if segment can be read, selector in <i>r/m16</i>    |
| 0F 00 /5 | VERW <i>r/m16</i> | <i>pm</i> =15/16 | Set ZF=1 if segment can be written, selector in <i>r/m16</i> |

### Operation

```
IF segment (*selector at (r/m)*) accessible with CPL
AND ((segment is readable for VERR)
OR (segment is writable for VERW)) THEN
    ZF := 1;
ELSE
    ZF := 0;
```

### Discussion

VERR/VERW's 2-byte register or memory operand contains the value of a selector. These instructions determine whether the segment denoted by the selector is accessible from the current privilege level and whether the segment is readable (VERR) or writable (VERW). The zero flag is set if the segment is accessible; otherwise, ZF is cleared. VERR/VERW set ZF only if:

- The selector denotes a descriptor within the bounds of the global/local descriptor table (GDT or LDT). (The selector must be defined.)
- The selector denotes the descriptor of a code or data segment (not that of a task state segment, LDT, or gate).
- The segment is readable for VERR, or writable for VERW.
- If the code segment is readable and conforming, the descriptor privilege level (DPL) can be any value for VERR. Otherwise, the DPL must be greater than or equal to (have less or the same privilege as) both the current privilege level (CPL) and the selector's RPL (requesting privilege level).

VERR/VERW perform the same segment validation checks as the LGS/LDS/LES/LFS instructions. (See the LGS/LSS/LDS/LES/LFS Operation section for details). However, VERR/VERW never raise a protection exception because the operand's selector is not loaded into a segment register. VERR/VERW validate the segment's accessibility, check its readability/writability, and then set ZF accordingly. Thus, ZF can be tested before a segment access problem occurs.

**Flags Affected**

ZF as described in the Discussion section

**Exceptions by Mode****Protected**

#GP(0) for an illegal memory operand effective address in the CS, DS, ES, FS, or GS segments; #SS(0) for an illegal address in the SS segment; #PF(fault-code) for a page fault

**Real Address**

Interrupt 6; `VERR` and `VERW` are not recognized in Real Address Mode

**Virtual 8086**

Same as Real Address Mode

## WAIT

---

**WAIT** Wait until BUSY# Pin is Inactive (HIGH)

| Opcode | Instruction | Clocks | Description                             |
|--------|-------------|--------|-----------------------------------------|
| 9B     | WAIT        | min. 6 | Wait until BUSY# pin is inactive (HIGH) |

### Discussion

WAIT suspends execution of processor instructions until the BUSY# pin is inactive (high). The BUSY# pin is driven by the floating-point coprocessor.

WAIT allows a check to be made for pending unmasked floating-point errors before the next floating-point coprocessor instruction executes.

See also: FWAIT instruction, Chapter 7

WAIT also synchronizes the processor with an Intel287 coprocessor.

### Flags Affected

None

### Exceptions by Mode

#### Protected

#NM if the task-switched flag is set in the machine status word (the lower 16-bits of register CR0); #MF if the ERROR# input pin is asserted (i.e., the floating-point coprocessor has detected an unmasked numeric error)

#### Real Address

Same as Protected Mode

#### Virtual 8086

Same as Protected Mode

**WBINVD** Write Back And Invalidate Data Cache  
(not available on Intel386 or 376 processors)

| Opcode | Instruction | Clocks | Description                      |
|--------|-------------|--------|----------------------------------|
| 0F 09  | WBINVD      | —      | Write back then flush data cache |

## Operation

```
FOR ALL CacheEntries DO
  WriteBack(CacheEntry);
  Bit[CacheEntry,Valid] := 0;
```

## Discussion

WBINVD writes back and invalidates (flushes) all entries in the data cache. The entries are flushed by resetting their valid bits. This instruction takes no operand.

## Flags Affected

None

## Exceptions by Mode

### Protected

None

### Real Address

None

### Virtual 8086

None

## XADD Exchange Add (not available on Intel386 or 376 processors)

| Opcode   | Instruction           | Clocks | Description                                                                                      |
|----------|-----------------------|--------|--------------------------------------------------------------------------------------------------|
| 0F C0 /r | XADD <i>r/m8,r8</i>   | —      | Exchanges values of <i>r/m8</i> and <i>r8</i> , adds them, and moves the sum into <i>r/m8</i>    |
| 0F C1 /r | XADD <i>r/m16,r16</i> | —      | Exchanges values of <i>r/m16</i> and <i>r16</i> , adds them, and moves the sum into <i>r/m16</i> |
| 0F C1 /r | XADD <i>r/m32,r32</i> | —      | Exchanges values of <i>r/m32</i> and <i>r32</i> , adds them, and moves the sum into <i>r/m32</i> |

## Operation

```
IF OperandSize = 8 (*r/m8, r8*) THEN
    temp := r/m8;
    r/m8 := r8 + temp;
    r8 := temp;
IF OperandSize = 16 (*r/m16, r16*) THEN
    temp := r/m16;
    r/m16 := r16 + temp;
    r16 := temp;
IF OperandSize = 32 (*r/m32, r32*) THEN
    temp := r/m32;
    r/m32 := r32 + temp;
    r32 := temp;
```

## Discussion

XADD exchanges the contents of the first operand with the second operand, adds them, copies their sum into the first operand, and sets the flags accordingly.

The LOCK prefix is only valid for the forms of XADD which involve memory operands.

## Flags Affected

OF, SF, ZF, AF, PF, and CF as described in Appendix A

## Exceptions by Mode

### Protected

#GP(0) if either operand is in a nonwritable segment; #GP(0) for an illegal memory operand effective address in the CS, DS, ES, FS, or GS segments; #SS(0) for an illegal address in the SS segment; #PF(fault-code) for a page fault

### Real Address

Interrupt 13 if any part of the operand would lie outside the effective address space from 0 to 0FFFFH

### Virtual 8086

Same as Real Address Mode; #PF(fault-code) for a page fault

## XCHG Exchange Register/Memory with Register

| Opcode        | Instruction                    | Clocks | Description                                   |
|---------------|--------------------------------|--------|-----------------------------------------------|
| 90+ <i>r</i>  | XCHG AX, <i>r16</i>            | 3      | Exchange word register with AX                |
| 90+ <i>r</i>  | XCHG <i>r16</i> ,AX            | 3      | Exchange word register with AX                |
| 90+ <i>r</i>  | XCHG EAX, <i>r32</i>           | 3      | Exchange dword register with EAX              |
| 90+ <i>r</i>  | XCHG <i>r32</i> ,EAX           | 3      | Exchange dword register with EAX              |
| 86 / <i>r</i> | XCHG <i>r/m8</i> , <i>r8</i>   | 3      | Exchange <i>r/m</i> byte with byte register   |
| 86 / <i>r</i> | XCHG <i>r8</i> , <i>r/m8</i>   | 3/5    | Exchange byte register with <i>r/m</i> byte   |
| 87 / <i>r</i> | XCHG <i>r/m16</i> , <i>r16</i> | 3      | Exchange <i>r/m</i> word with word register   |
| 87 / <i>r</i> | XCHG <i>r16</i> , <i>r/m16</i> | 3/5    | Exchange word register with <i>r/m</i> word   |
| 87 / <i>r</i> | XCHG <i>r/m32</i> , <i>r32</i> | 3      | Exchange <i>r/m</i> dword with dword register |
| 87 / <i>r</i> | XCHG <i>r32</i> , <i>r/m32</i> | 3/5    | Exchange dword register with <i>r/m</i> dword |

### Operation

```
temp := Dest;  
Dest := Src;  
Src := temp;
```

### Discussion

XCHG swaps two operands. For a memory operand, bus LOCK# is asserted for the duration of the exchange, regardless of the presence or absence of the LOCK prefix or of the value of IOPL.

### Flags Affected

None

### Exceptions by Mode

#### Protected

#GP(0) if either operand is in a nonwritable segment; #GP(0) for an illegal memory operand effective address in the CS, DS, ES, FS, or GS segments; #SS(0) for an illegal address in the SS segment; #PF(fault-code) for a page fault

**Real Address**

Interrupt 13 if any part of the operand would lie outside the effective address space from 0 to 0FFFFH

**Virtual 8086**

Same as Real Address Mode; #PF(fault-code) for a page fault

## XLAT/XLATB Table Look-up Translation

| Opcode | Instruction    | Clocks | Description                                     |
|--------|----------------|--------|-------------------------------------------------|
| D7     | XLAT <i>m8</i> | 5      | Set AL to memory byte DS:[ (E)BX + unsigned AL] |
| D7     | XLATB          | 5      | Set AL to memory byte DS:[ (E)BX + unsigned AL] |

### Operation

```
IF AddressSize = 16 THEN
    AL := [ (BX + ZeroExtend(AL) ) ];
ELSE (*AddressSize = 32*)
    AL := [ (EBX + ZeroExtend(AL) ) ];
```

### Discussion

XLAT changes the AL register from the table index to the table entry. AL should be the unsigned index into a table addressed by DS:BX (for an address size attribute of 16-bits) or DS:EBX (for an address size attribute of 32-bits).

XLAT allows a segment override. XLAT uses (E)BX even if its contents differ from the operand's offset. The offset should have been moved into (E)BX by a preceding instruction.

XLATB can be used only if the (E)BX table always resides in the DS segment.

### Flags Affected

None

### Exceptions by Mode

#### Protected

#GP(0) for an illegal memory operand effective address in the CS, DS, ES, FS, or GS segments; #SS(0) for an illegal address in the SS segment; #PF(fault-code) for a page fault

**Real Address**

Interrupt 13 if any part of the operand would lie outside the effective address space from 0 to 0FFFFH

**Virtual 8086**

Same as Real Address Mode; #PF(fault-code) for a page fault

## XOR Logical Exclusive OR

| Opcode          | Instruction                     | Clocks | Description                                          |
|-----------------|---------------------------------|--------|------------------------------------------------------|
| 34 <i>ib</i>    | XOR AL, <i>imm8</i>             | 2      | Exclusive-OR immediate byte to AL                    |
| 35 <i>iw</i>    | XOR AX, <i>imm16</i>            | 2      | Exclusive-OR immediate word to AX                    |
| 35 <i>id</i>    | XOR EAX, <i>imm32</i>           | 2      | Exclusive-OR immediate dword to EAX                  |
| 80 /6 <i>ib</i> | XOR <i>r/m8</i> , <i>imm8</i>   | 2/7    | Exclusive-OR immediate byte to <i>r/m</i> byte       |
| 81 /6 <i>iw</i> | XOR <i>r/m16</i> , <i>imm16</i> | 2/7    | Exclusive-OR immediate word to <i>r/m</i> word       |
| 81 /6 <i>id</i> | XOR <i>r/m32</i> , <i>imm32</i> | 2/7    | Exclusive-OR immediate dword to <i>r/m</i> dword     |
| 83 /6 <i>ib</i> | XOR <i>r/m16</i> , <i>imm8</i>  | 2/7    | XOR sign-extended immediate byte to <i>r/m</i> word  |
| 83 /6 <i>ib</i> | XOR <i>r/m32</i> , <i>imm8</i>  | 2/7    | XOR sign-extended immediate byte to <i>r/m</i> dword |
| 30 / <i>r</i>   | XOR <i>r/m8</i> , <i>r8</i>     | 2/6    | Exclusive-OR byte register to <i>r/m</i> byte        |
| 31 / <i>r</i>   | XOR <i>r/m16</i> , <i>r16</i>   | 2/6    | Exclusive-OR word register to <i>r/m</i> word        |
| 31 / <i>r</i>   | XOR <i>r/m32</i> , <i>r32</i>   | 2/6    | Exclusive-OR dword register to <i>r/m</i> dword      |
| 32 / <i>r</i>   | XOR <i>r8</i> , <i>r/m8</i>     | 2/7    | Exclusive-OR <i>r/m</i> byte to byte register        |
| 33 / <i>r</i>   | XOR <i>r16</i> , <i>r/m16</i>   | 2/7    | Exclusive-OR <i>r/m</i> word to word register        |
| 33 / <i>r</i>   | XOR <i>r32</i> , <i>r/m32</i>   | 2/7    | Exclusive-OR <i>r/m</i> dword to dword register      |

## Operation

```
Dest := LeftSrc XOR RightSrc;  
CF := 0;  
OF := 0;
```

## Discussion

XOR computes the exclusive OR of the two operands. A corresponding bit of the result is 1 if the corresponding bits of the operands are different; a bit is 0 if the corresponding bits are the same. The result replaces the first operand.

## Flags Affected

CF = 0, OF = 0; SF, ZF, and PF as described in Appendix A; AF is undefined

---

## Exceptions by Mode

### Protected

#GP(0) if the result is in a nonwritable segment; #GP(0) for an illegal memory operand effective address in the CS, DS, ES, FS, or GS segments; #SS(0) for an illegal address in the SS segment; #PF(fault-code) for a page fault

### Real Address

Interrupt 13 if any part of the operand would lie outside the effective address space from 0 to 0FFFFH

### Virtual 8086

Same as Real Address Mode; #PF(fault-code) for a page fault





This chapter contains four major sections:

- A summary discussion of the floating-point coprocessor architecture. This discussion applies to the built-in floating-point unit of the Intel486 processor, as well as the Intel287 and Intel387 floating-point coprocessors.
- A brief description of floating-point coprocessor operation as background in numeric processing and exception handling.
- An overview of the floating-point coprocessor instructions: their functional classifications and operands.
- An explanation of the notational conventions used in this chapter, followed by a detailed reference for each floating-point instruction.

See also: Floating-point coprocessor architecture and coprocessor operation, and writing exception handlers, *80387 Programmer's Reference* or *iAPX 286 Programmer's Reference*

## Floating-point Coprocessor Architecture

The programmer-accessible features of the floating-point coprocessor architecture are:

- Eight floating-point registers organized as a stack
- Environment: the floating-point coprocessor status, control and tag words, together with instruction and operand pointers
- Seven numeric data types: the word, short, and long integers, packed BCD integers, and the single, double, and extended precision reals

# Floating-point Stack

The floating-point coprocessor stack consists of eight registers divided into the fields shown in Figure 7-1 and accessed relative to the current stack top element ST(0). The format of the fields corresponds with the extended precision real data format used in all stack calculations.

See also: Data Formats, in this chapter

The TOP field of the floating-point coprocessor status word identifies the current stack top register. This floating-point stack element is an implicit or explicit operand of every floating-point coprocessor instruction; it is addressed as ST(0) or simply as ST. (In the rest of this chapter, the stack top element is called ST.) Every other stack element is addressed relative to the current stack top element. ST(1) is the first element below the current ST, ST(2) is the next element below ST(1), ..., and ST(7) is the bottom stack element.

But, as Figure 7-1 shows, ST is not necessarily stack\_register(0). If the TOP field of the status word indicates that stack\_register(3) is ST, then stack\_register(4) is ST(1). In other words, ST(1) corresponds to the stack\_register indexed by TOP + 1.

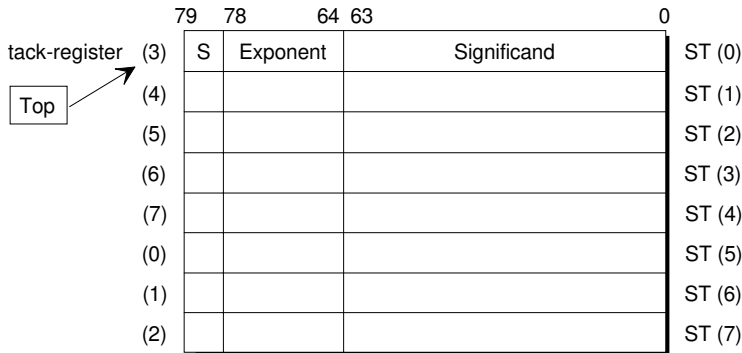

W-3426

**Figure 7-1. Floating-point Coprocessor Stack Fields**

A load (push) operation, such as FLDLN2, decrements TOP by 1 and loads a value (in this case log<sub>e</sub>2) into the new stack top element.

An operation that pops the floating-point stack increments `TOP` by 1. For example, the instruction `FADDP ST(i)`, `ST` adds the contents of the stack top register to the stack element designated by (*i*), stores the result in `ST(i)`, frees the top of stack, and increments `TOP` by 1. This makes the former `ST(1)` the new `ST`.

Elements of the floating-point stack can be addressed either implicitly or explicitly. As two examples of implicit addressing:

- `FST ST(3)` stores the contents of `ST` into the third stack element below `ST`.
- `FADD` adds the contents of `ST` to the contents of `ST(1)`, stores the result in `ST(1)`, and then pops the stack.

## Environment

The floating-point coprocessor environment consists of the control, status, and tag words, together with the current instruction and operand pointers. The `FSTENV` and `FSAVE` instructions store the floating-point coprocessor environment, while `FLDENV` and `FRSTOR` load an environment from memory. The size and layout of an environment depend on the `USE` attribute of the code segment in which the `FSTENV/FSAVE/FLDENV/FRSTOR` instruction appears. Figure 7-2 shows the floating-point coprocessor environments for the processor protected and real address modes when the `USE` attribute is `USE16`.

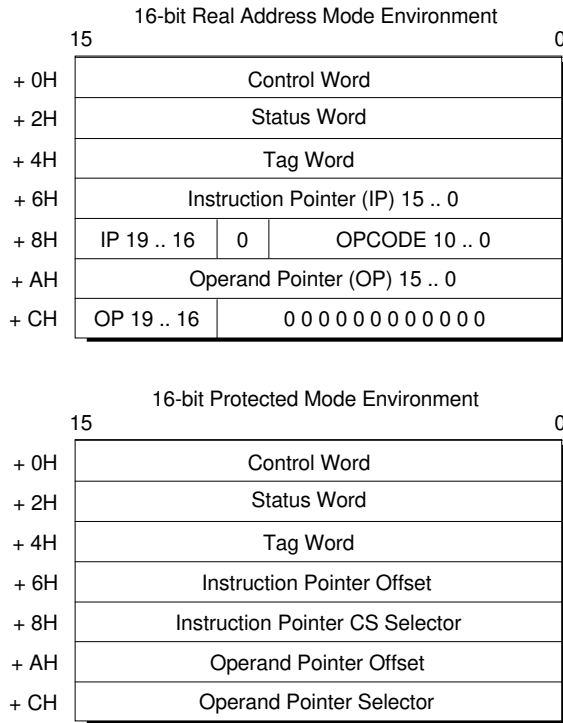

W-3427

**Figure 7-2. 16-bit Environments**

Figure 7-3 shows the environments when the `USE` attribute is `USE32`. Environments for virtual 8086 mode are identical to those of the real address mode.

In all floating-point coprocessor environments, the control word, the status word, and the tag word have the same meaning. The remaining components (IP and OP) identify the location of an instruction and its operand (if it has an operand).

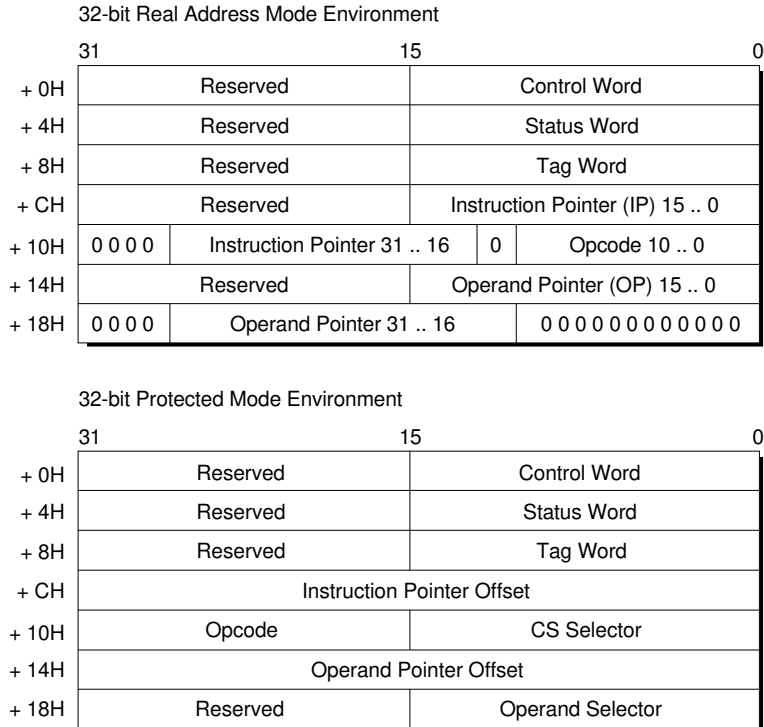

W-3428

**Figure 7-3. 32-bit Environments**

## Status Word

The status word reflects the overall condition of the floating-point co-processor. The floating-point coprocessor instructions `FSTSW AX/FNSTSW AX` transfer the status word into the processor `AX` register. Then, processor code can inspect the status word information and do conditional branching, pass control to exception handlers, etc.

The status word is divided into the exception flag fields and the status fields shown in Figure 7-4.

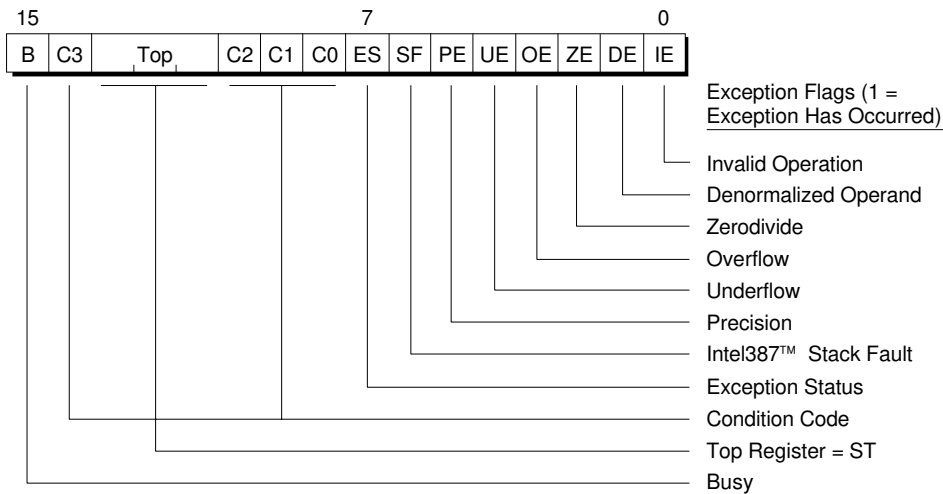

W-3429

**Figure 7-4. Status Word Format**

The low-order bits of the status word indicate which exceptions have occurred. Both the Intel287 and Intel387 coprocessors set bits 5..0 for precision (PE), underflow (UE), overflow (OE), zerodivide (ZE), denormalized (DE), and invalid (IE) operations.

See also: Exception masks, in the Control Word section of this chapter

The Intel387 coprocessor status word indicates an invalid operation due to stack overflow or underflow by setting the SF bit (6) along with the IE bit (0). When both SF and IE are set, the C1 condition code bit (9) indicates whether stack overflow (C1 = 1) or underflow (C1 = 0) has occurred.

The Intel287 coprocessor status word does not distinguish between invalid operations caused by stack overflow/underflow and those caused by illegal arithmetic operations. Bit 6 of the Intel287 coprocessor status word is reserved.

The exception status bit (7) of the floating-point coprocessor status word is set (1) if any unmasked exception bits are set and is clear (0) otherwise. If ES is set, the ERROR# signal is asserted.

The condition code bits (14 and 10..8) are set by several floating-point coprocessor instructions. The condition code is frequently used for conditional branching. For more information about the interpretation of these bits, see the following instructions later in this chapter: FCOM/FCOMP/FCOMPP, FUCOM/FUCOMP/FUCOMPP, FTST, FXAM, and FPREM/FPREML.

The TOP bits (13..11) of the status word indicate which floating-point coprocessor internal register is the current stack top. TOP can have the following binary values:

000 = stack\_register(0) is stack top  
001 = stack\_register(1) is stack top  
: :  
111 = stack\_register(7) is stack top

Pushing the stack with TOP equal to 000B sets the status word TOP bits to 111B; popping the stack with TOP equal to 111B sets the status word TOP bits to 000B.

The busy bit (15) of the status word:

- Reflects the contents of the Intel387 coprocessor ES bit (7), not the status of the BUSY# output of the Intel387 coprocessor
- Or, indicates whether the Intel287 coprocessor is idle (B = 0) or is currently executing an instruction or signaling an exception (B = 1).

## Control Word

The floating-point coprocessor control word consists of the exception masks and control fields as shown in Figure 7-5.

The high-order bits 12..8 of the control word have the following meanings:

PC (9..8) Precision Control specifies the significand length for FADD, FSUB(R), FMUL, FDIV(R), and SQRT operands as 64-bits, 53-bits, or 24-bits.

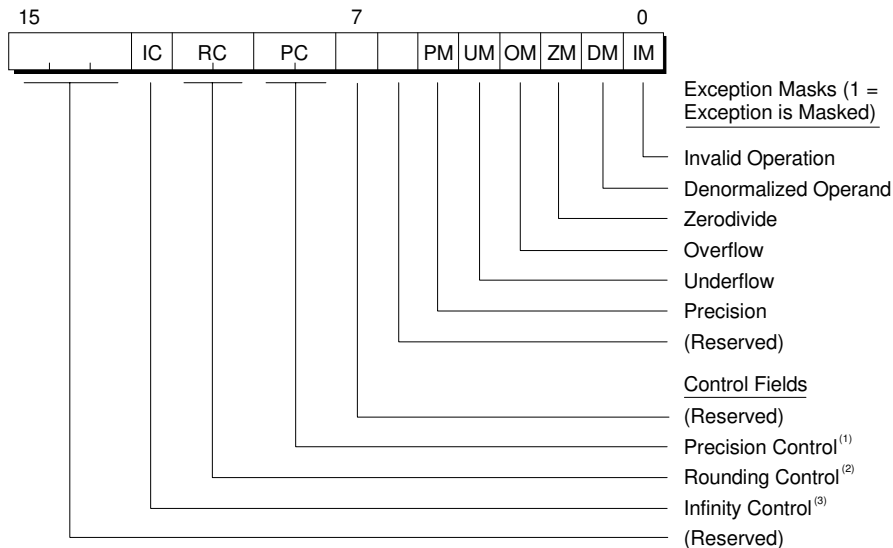

<sup>1</sup>Precision Control:

- 00 = 24 Bits
- 01 = (Reserved)
- 10 = 53 Bits
- 11 = 64 Bits

<sup>2</sup>Rounding Control:

- 00 = Round to Nearest or Even
- 01 = Round Down (Toward  $-\infty$ )
- 10 = Round Up (Toward  $+\infty$ )
- 11 = Chop (Truncate Toward Zero)

<sup>3</sup>Intel287™ Infinity Control:

- 0 = Projective
  - 1 = Affine
- 80387: 0 or 1 = Affine

W-3430

**Figure 7-5. Control Word Format**

- RC** (11..10) Rounding Control rounds results in one of four directions: unbiased round to nearest with even preferred, round toward  $+\infty$ , round toward  $-\infty$ , or round toward 0 (chop). This control determines the rounding method when an exact mathematical result requires more bits than the destination format has available.
- IC** (12) Intel287 coprocessor Infinity Control provides two types of Intel287 coprocessor infinity arithmetic, affine and projective. The Intel287 coprocessor default is projective. The Intel387 coprocessor has only affine (in compliance with the IEEE 754 standard).

The low-order bits 5..0 of the control word mask/unmask exceptions. When a floating-point coprocessor exception occurs, the corresponding exception flag is set to 1. If the exception is unmasked, the ES bit in the status word is also set to 1. The floating-point coprocessor then checks the appropriate mask in the control word to determine whether it should:

- Process the exception with its on-chip exception handling procedure (mask is 1: the exception is masked from software)
- Pass control to a software exception handler (mask is 0) by asserting the ERROR# line

During the execution of most instructions, the floating-point coprocessor checks for six classes of exception conditions:

1. Invalid exceptions are caused by programming errors such as:
  - Trying to load onto a floating-point stack element that is not empty,
  - Popping an operand from an element that is empty,
  - Using operands that cause indeterminate results (0/0, square root of a negative number, etc.).
2. Denormalized exceptions occur when an instruction attempts to operate on a denormalized number.
3. Zerodivide exceptions occur when an operation on finite operands will produce an infinite result.
4. Overflow exceptions occur when the exponent of the rounded result is too large for the format of the destination.
5. Intel387 coprocessor underflow exceptions depend on the UM value of the control word:
  - 0: If UM is clear (unmasked), underflow exceptions occur when a non-zero result (rounded as though its exponent range were unbound) would be too small for the format of the destination.
  - 1: If UM is set (masked), underflow exceptions occur when such a result (rounded to the destination format) is also inexact.

Intel287 coprocessor underflow exceptions occur when the true exponent is too small for the result format.
6. Precision exceptions occur when the exact mathematical result did not fit in the result format.

## Tag Word

The tag word, as shown in Figure 7-6, contains tags that classify the contents of the corresponding stack elements as valid, zero, invalid, or empty.



Tag Values:

- 00 = Valid (Normal or Unnormal)
- 01 = Zero (True)
- 10 = Invalid (or Special)
- 11 = Empty

W-3431

**Figure 7-6. Tag Word Format**

The Intel387 coprocessor generates exact values for these tags during execution of the `FSTENV` and `FSAVE` instructions. For all other instructions, the Intel387 coprocessor updates the tag word only to indicate whether a stack location is empty or not. After Intel387 coprocessor `FSTENV` or `FSAVE`, the tag values indicate whether each stack element contained one of the following:

- Valid        An extended precision real value
- Zero        +0.0 or -0.0
- Invalid     (or Special):  $+\infty$ ,  $-\infty$ , pseudoinfinity, NaN (not-a-number), pseudo-NaN, a denormal, or an unsupported format (including 8087/Intel287 coprocessor unnormals, pseudozeros, and pseudodenormals)
- Empty      No value

The Intel287 coprocessor tag values indicate that each stack element contains one of the following:

- Valid        An extended precision real value or an unnormal
- Zero        +0.0 or -0.0
- Invalid     (or Special):  $+\infty$ ,  $-\infty$ , NaN, denormal, or pseudodenormal
- Empty      No value

## Operation Locator Formats

The opcode, IP (instruction pointer), and OP (operand pointer) fields of the floating-point coprocessor environment support programmers who write software exception handlers. Whenever the processor decodes a floating-point coprocessor instruction, it saves the opcode and pointer(s) to the instruction and operand (if any). (The floating-point coprocessor `FLDENV`, `FSTENV`, `FSAVE`, and `FRSTOR` instructions access this data.)

Figures 7-7 and 7-8 illustrate these parts of the floating-point coprocessor environment.

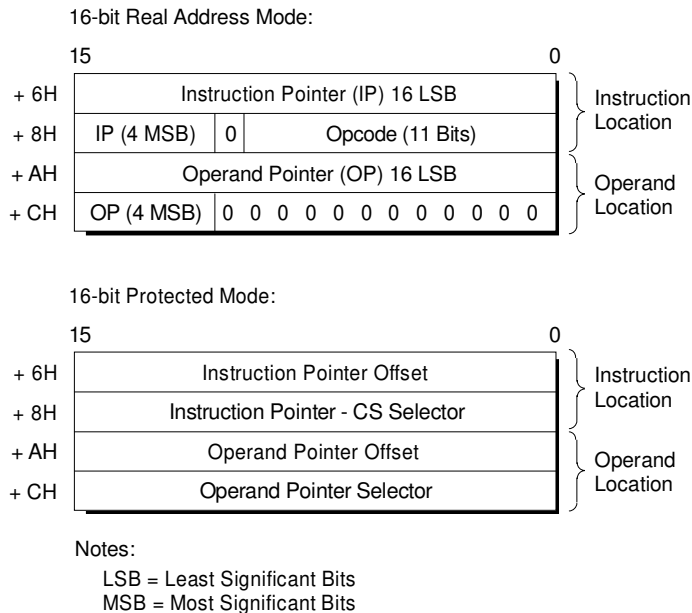

W-3432

**Figure 7-7. 16-bit Opcode, IP, and Op Environment Formats**

Exception handlers can be written to store these locations in memory and obtain information concerning the instruction that caused the error.

In the 32-bit real address (and virtual 8086) mode environment, the instruction pointer (IP) and operand pointer (OP) are formed by shifting the 16-bit segment left by four to form a 20-bit quantity, and then adding this quantity to the 32-bit offset.

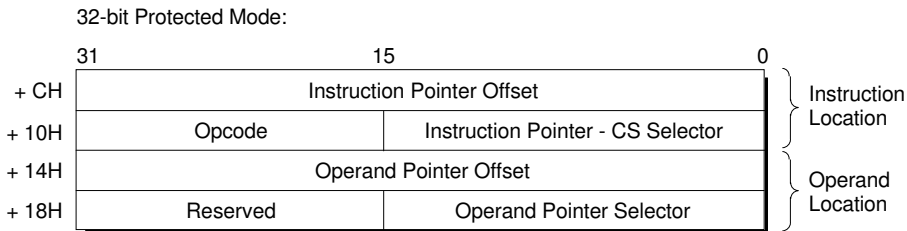
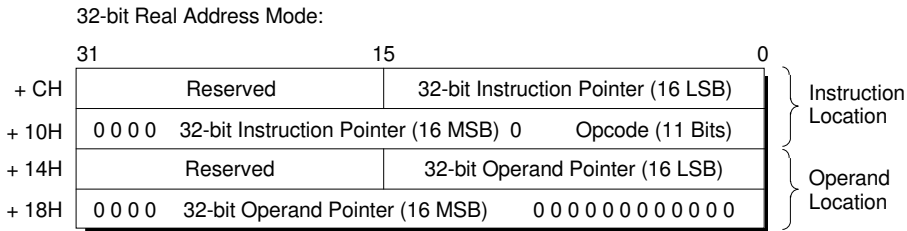

Notes:  
 LSB = Least Significant Bits  
 MSB = Most Significant Bits

W-3433

**Figure 7-8. 32-bit Opcode, IP, and OP Environment Formats**

## Floating-point Coprocessor Data Formats

The floating-point coprocessor accesses seven different data formats using all of the processor addressing modes. Figure 7-9 illustrates how these formats are stored in memory.

### ⇒ Note

Figure 7-9's terms for real formats, like the Intel387 coprocessor, comply with the IEEE 754 standard. The following Intel387 coprocessor and 8087/Intel287 coprocessor terms are equivalent:

| <b>Intel387 Coprocessor</b> | <b>8087/Intel287 Coprocessor</b> |
|-----------------------------|----------------------------------|
| single precision real       | = short real                     |
| double precision real       | = long real                      |
| extended precision real     | = temporary real                 |

| Data Formats       | Approx. Range   | Precision | MSB                                                                                                            |                 |                      |             |             |   |   |   |   |   | LSB |   |   |  |  |  |  |  |  |   |   |
|--------------------|-----------------|-----------|----------------------------------------------------------------------------------------------------------------|-----------------|----------------------|-------------|-------------|---|---|---|---|---|-----|---|---|--|--|--|--|--|--|---|---|
|                    |                 |           | 7                                                                                                              | 0               | 7                    | 0           | 7           | 0 | 7 | 0 | 7 | 0 |     | 7 | 0 |  |  |  |  |  |  |   |   |
| Word Integer       | $10^4$          | 16 Bits   | <div style="border: 1px solid black; width: 100%; height: 15px; margin-bottom: 5px;"></div> (Two's Complement) |                 |                      |             |             |   |   |   |   |   |     |   |   |  |  |  |  |  |  |   |   |
| Short Integer      | $10^9$          | 32 Bits   | <div style="border: 1px solid black; width: 100%; height: 15px; margin-bottom: 5px;"></div> (Two's Complement) |                 |                      |             |             |   |   |   |   |   |     |   |   |  |  |  |  |  |  |   |   |
| Long Integer       | $10^{19}$       | 64 Bits   | <div style="border: 1px solid black; width: 100%; height: 15px; margin-bottom: 5px;"></div> (Two's Complement) |                 |                      |             |             |   |   |   |   |   |     |   |   |  |  |  |  |  |  |   |   |
| Packed BCD         | $10^{18}$       | 18 Digits | S                                                                                                              | N               | Magnitude 18 Digits* |             |             |   |   |   |   |   |     |   | 0 |  |  |  |  |  |  |   |   |
| Single Precision   | $10^{\pm 38}$   | 24 Bits   | S                                                                                                              | Biased Exp.     |                      | Significand |             |   |   |   |   |   |     |   |   |  |  |  |  |  |  | 0 |   |
| Double Precision   | $10^{\pm 308}$  | 53 Bits   | S                                                                                                              | Biased Exponent |                      | Significand |             |   |   |   |   |   |     |   |   |  |  |  |  |  |  | 0 |   |
| Extended Precision | $10^{\pm 4932}$ | 64 Bits   | S                                                                                                              | Biased Exponent |                      | 1           | Significand |   |   |   |   |   |     |   |   |  |  |  |  |  |  |   | 0 |

S = Sign bit (0 = positive, 1 = negative)  
 \* = Decimal digit (two per byte)  
 N = If set, indicates BCD NaN indefinite  
 $\Delta$  = Position of implicit binary point  
 I = Integer bit of significand: explicit in extended precision  
     real, implicit in single and double precision  
 Exponent Bias (normalized values):  
 Single: 127 (7FH)  
 Double: 1023 (3FFH)  
 Extended Real: 16383 (3FFFH)  
 Packed BCD:  $(-1)^S (d_{17} \dots d_0)$   
 Real:  $(-1)^S (2^{E-BIAS})$  (significand bits)

W-3434

**Figure 7-9. Data Formats**

The integer, BCD, single precision real, and double precision real formats exist only in memory. The floating-point coprocessor converts each memory operand in one of these formats to extended precision real whenever such an operand is loaded onto the stack.

The three binary integer formats are identical except for length, which governs the range that can be accommodated in each format. Integers are represented in standard two's complement notation. The integer 0 is represented with all bits 0. The floating-point coprocessor word integer format corresponds to the 16-bit signed integer data type of the processor.

The floating-point coprocessor BCD integer format has two (binary coded) decimal digits packed into each byte: each nibble holds one decimal digit. Therefore, all BCD digits must be in the range 0H through 9H when the floating-point coprocessor loads such an operand from memory. Negative BCD integers are not stored in two's complement; they are distinguished from positive numbers only by the sign bit.

The floating-point coprocessor real formats resemble scientific notation. These numbers have a three-field binary format:

1. The number's significant bits are in the significand field.
2. The exponent field locates the binary point within the significand field.
3. The sign field indicates whether the number is positive or negative.

Negative real numbers differ from positive numbers only in their sign bits. Table 7-1 summarizes the format parameters for real numbers.

**Table 7-1. Summary of Real Format Parameters**

| Parameter                  | Real Number Format |        |          |
|----------------------------|--------------------|--------|----------|
|                            | Single             | Double | Extended |
| Format width in bits       | 32                 | 64     | 80       |
| P (bits of precision)      | 24                 | 53     | 64       |
| Exponent width in bits     | 8                  | 11     | 15       |
| E <sub>max</sub>           | +127               | +1023  | +16383   |
| E <sub>min</sub>           | -126               | -1022  | -16382   |
| Exponent bias (normalized) | +127               | +1023  | +16383   |

The floating-point coprocessor also recognizes certain special floating-point values, although they are not within the domain of normal floating-point arithmetic. These special values are listed here:

- Signed zero
- Signed infinity
- Indefinite values
- NaN values (Not-a-Number)
- Denormals and pseudodenormals
- Intel387 coprocessor unsupported format/Intel287 coprocessor unnormals, pseudozeros

For more information about these values, consult the Programmer's Reference for your coprocessor.

## Coprocessor Operation

The processor has a section of its opcode space dedicated to floating-point instructions. When the processor decodes a floating-point opcode, it transmits the necessary information (opcode and any memory address operands) to the floating-point coprocessor. The information is transmitted through the reserved I/O address 800000F8H for instructions and 800000FCH for data. The processor continues executing while the floating-point coprocessor processes the instruction in parallel.

If the floating-point coprocessor requires access to memory, it makes a request through a built-in data channel in the processor dedicated to coprocessor usage. If such a request violates processor protection rules, a processor exception is generated. This can happen at any time during processor instruction execution.

If the floating-point coprocessor detects an unmasked numeric exception, it sends a signal on its dedicated ERROR# line. The processor samples this line when executing `WAIT` or before most floating-point instructions and produces an exception (interrupt) at that time. Floating-point instructions that begin with `FN` (except `FNOP`) do not test for a pending numeric error.

No error status is transmitted to the processor when an exception is masked. However, the floating-point coprocessor status word's `ES` bit remains set until it is explicitly cleared. This can be done by the `FNCLEX`, `FNSAVE`, `FNSTENV` or `FNINIT` instructions.

## Numeric Processing

The Intel287 and Intel387 coprocessors have four rounding methods that can be set in the RC field of the control word. The rounding methods and their corresponding RC fields are shown in Table 7-2.

**Table 7-2. Rounding Methods**

| RC Field | Rounding Method                | Rounding Action †                                                                    |
|----------|--------------------------------|--------------------------------------------------------------------------------------|
| 00       | To nearest with even preferred | Closer to $b$ of $a$ or $c$ ; if equally close, select even number (with $LSB = 0$ ) |
| 01       | Down toward $-\infty$          | $a$                                                                                  |
| 10       | Up toward $+\infty$            | $c$                                                                                  |
| 11       | Chop toward 0                  | Smaller in magnitude of $a$ or $c$ .                                                 |

†  $a$  and  $c$  are successively representable numbers such that  $a < b < c$  where  $b$  is not a representable number.

Rounding occurs in arithmetic and store operations when the format of the destination cannot exactly represent the true result. Rounding introduces an error in the result; this error is less than one unit in the last place of the destination format.

Round to nearest with even preferred is the default method for both coprocessors. This is suitable for most applications.

See also: *Programmer's Reference* for your coprocessor for more information about the other rounding methods

The Intel287 and Intel387 coprocessors can calculate the precision of results to 64-, 53-, or 24-bits for addition, subtraction, multiplication, division, and square root. The PC field of the control word specifies the degree of precision. The default PC setting for both coprocessors is 64-bits. Specifying less precision allows the floating-point coprocessor to mimic calculations on a floating-point unit with less precision.

The Intel287 coprocessor's system of real numbers can be closed by either of two models of infinity. The IC bit in the Intel287 coprocessor control word specifies either projective or affine closure. The default is projective. Under this closure, the Intel287 coprocessor treats the special values  $+\infty$  and  $-\infty$  as a single, unsigned infinity.

The IEEE 754 system of real numbers is closed by the affine model of infinity. Although the IC bit of the Intel387 coprocessor control word can be set or cleared, the Intel387 coprocessor complies with the IEEE standard. For this reason, Intel287 coprocessor applications that use projective closure may produce unexpected Intel387 coprocessor results with respect to infinity.

It is important to remember that computer arithmetic on real numbers is inherently approximate. The floating-point coprocessor produce real arithmetic results that are as accurate as the destination format allows. The floating-point coprocessors perform exact arithmetic on their subset of the integers. An operation on two integers returns an exact integral result, provided that the true result is an integer and is in range.

The floating-point coprocessor can detect six exceptions. You can use the floating-point coprocessor on-chip exception-handling capability, or you can write your own exception handlers.

In either case, consult your coprocessor's Programmer's Reference manual for:

- Detailed information about the on-chip (default) exception handling of your coprocessor
- Information about how to write an exception handler, because exception handlers vary widely from one application to the next

See also: Exceptions, Environment section of this chapter

# Overview of the Floating-point Coprocessor Instruction Set

This section groups the floating-point coprocessor instructions according to their general functions. The Intel387 coprocessor executes all of the Intel287 coprocessor instructions. Intel387 coprocessor-only instructions are flagged in the tables of this section. For details of any particular instruction, see the reference pages at the end of this chapter.

## Data Transfer Instructions

The data transfer instructions move operands between stack elements or between the stack top and memory. These instructions are summarized in Table 7-3.

**Table 7-3. Data Transfer Instructions**

|       |                                   |
|-------|-----------------------------------|
| FLD   | Load real                         |
| FST   | Store real                        |
| FSTP  | Store real and pop                |
| FXCH  | Exchange stack elements           |
| FILD  | Load integer onto ST              |
| FIST  | Store integer                     |
| FISTP | Store integer and pop             |
| FBLD  | Load packed decimal (BCD) onto ST |
| FBSTP | Store packed decimal and pop      |

Any of the floating-point coprocessor data formats can be converted to extended precision real and loaded (pushed) onto the stack in a single operation. They also can be stored in memory in a single operation. The data transfer instructions automatically update the floating-point coprocessor tag word to reflect the stack contents following the instruction.

## Constant Instructions

Each of the instructions shown in Table 7-4 loads (pushes) a commonly used constant onto the stack.

**Table 7-4. Constant Instructions**

|        |                            |
|--------|----------------------------|
| FLDZ   | Load +0.0 onto ST          |
| FLD1   | Load +1.0 onto ST          |
| FLDPI  | Load $\pi$ onto ST         |
| FLDL2T | Load $\log_2 10$ onto ST   |
| FLDL2E | Load $\log_2 e$ onto ST    |
| FLDLG2 | Load $\log_{10} 2$ onto ST |
| FLDLN2 | Load $\log_e 2$ onto ST    |

The values have full extended precision (64-bits) and are accurate to approximately 19 decimal digits. The constant instructions are only 2 bytes long; they save storage (an extended precision real constant occupies 10 memory bytes) and improve execution speed.

## Algebraic Instructions

The floating-point coprocessor algebraic instructions provide many variations on the basic add, subtract, multiply, and divide operations, and a number of other useful functions. Table 7-5 gives a summary of these instructions.

**Table 7-5. Algebraic Instructions**

|         |                                                                              |
|---------|------------------------------------------------------------------------------|
| FADD    | Add real                                                                     |
| FADDP   | Add real and pop                                                             |
| FIADD   | Add integer                                                                  |
| FSUB    | Subtract real                                                                |
| FSUBP   | Subtract real and pop                                                        |
| FSUBR   | Subtract real reversed                                                       |
| FSUBRP  | Subtract real reversed and pop                                               |
| FISUB   | Subtract integer                                                             |
| FISUBR  | Subtract integer reversed                                                    |
| FMUL    | Multiply real                                                                |
| FMULP   | Multiply real and pop                                                        |
| FIMUL   | Multiply integer                                                             |
| FDIV    | Divide real                                                                  |
| FDIVP   | Divide real and pop                                                          |
| FDIVR   | Divide real reversed                                                         |
| FDIVRP  | Divide real reversed and pop                                                 |
| FIDIV   | Divide integer                                                               |
| FIDIVR  | Divide integer reversed                                                      |
| FSQRT   | Square root                                                                  |
| FSCALE  | Scale                                                                        |
| FPREM   | Partial remainder                                                            |
| FPREM1  | IEEE partial remainder(not available on Intel287 floating-point coprocessor) |
| FRNDINT | Round to integer                                                             |
| FXTRACT | Extract exponent and significand                                             |
| FABS    | Absolute value                                                               |
| FCHS    | Change sign                                                                  |

The two reversed instructions, `FSUBR` and `FDIVR`, make subtraction and division as symmetrical as addition and multiplication.

The floating-point coprocessor basic arithmetic instructions (addition, subtraction, multiplication, and division) either operate on two stack elements or on `ST` and a memory operand. The two-stack-element forms minimize memory references and make optimum use of the floating-point stack.

The other algebraic instructions operate on stack elements.

Table 7-6 summarizes the available operation/operand forms provided for basic arithmetic instructions.

**Table 7-6. Basic Arithmetic Instruction and Operand Forms**

| <b>Mnemonic Form</b>                                                                                                                                                         | <b>Operand(s) destination, source</b>                                   | <b>ASM386 Example</b>          | <b>Instruction Form</b>                |
|------------------------------------------------------------------------------------------------------------------------------------------------------------------------------|-------------------------------------------------------------------------|--------------------------------|----------------------------------------|
| <i>Fop</i>                                                                                                                                                                   | { <i>ST</i> (1), <i>ST</i> }                                            | FADD                           | Classical stack (includes pop)         |
| <i>FopP</i>                                                                                                                                                                  | { <i>ST</i> (1), <i>ST</i> }                                            | FADDP                          | Classical stack, extra pop             |
| <i>Fop</i>                                                                                                                                                                   | <i>ST</i> ( <i>i</i> ), <i>ST</i> or <i>ST</i> , <i>ST</i> ( <i>i</i> ) | FSUB <i>ST</i> , <i>ST</i> (3) | Stack element                          |
| <i>FopP</i>                                                                                                                                                                  | <i>ST</i> ( <i>i</i> ), <i>ST</i>                                       | FMULP <i>ST</i> (2), <i>ST</i> | Stack element with pop                 |
| <i>Fop</i>                                                                                                                                                                   | { <i>ST</i> ,} real                                                     | FDIV AZIMUTH                   | Memory single or double precision real |
| <i>Flop</i>                                                                                                                                                                  | { <i>ST</i> ,} integer                                                  | FIDIV NUM                      | Memory word or short integer           |
| Braces ({} ) surround implicit operands that are not coded; they are shown here for information only. <i>Fop</i> ( <i>P</i> ) is one of the following arithmetic operations: |                                                                         |                                |                                        |
|                                                                                                                                                                              | <i>op</i>                                                               |                                | <b>Operation</b>                       |
|                                                                                                                                                                              | ADD                                                                     |                                | destination := destination + source    |
|                                                                                                                                                                              | SUB                                                                     |                                | destination := destination - source    |
|                                                                                                                                                                              | SUBR                                                                    |                                | destination := source - destination    |
|                                                                                                                                                                              | MUL                                                                     |                                | destination := destination * source    |
|                                                                                                                                                                              | DIV                                                                     |                                | destination := destination / source    |
|                                                                                                                                                                              | DIVR                                                                    |                                | destination := source / destination    |

These instruction forms can be used across all six operations, as shown in Table 7-6:

- The classical stack form can be used to make the floating-point coprocessor operate like a classical stack machine. No operands are coded in this form; only the instruction mnemonic is coded. The floating-point coprocessor picks the source operand from the stack top and the destination from the next stack element. It then performs the operation, pops the stack, and returns the result to the new stack top.
- Often the stack top value is needed only for one operation. The stack element and pop form can be used to pick up the stack top as the source operand and then discard it by popping the floating-point stack. Coding operands ST(1),ST with a stack element pop mnemonic is equivalent to a classical stack operation: the top is popped and the result is left at the new top.
- The stack element forms are a generalization of the classical stack form: specify the stack top as one operand and any stack element as the other operand. Coding the stack top as the destination provides a convenient way to use a constant held elsewhere in the stack. Coding ST as the source operand provides a convenient way to add the top into a stack element used as an accumulator.
- The memory operand forms increase the flexibility of the arithmetic instructions. A number in memory can be used as a source operand directly when it is not used frequently enough to justify holding it in the floating-point stack.

## Comparison Instructions

Each comparison instruction in Table 7-7 analyzes the top stack element, often in relationship to another operand, and reports the result in the floating-point coprocessor status word condition code. The `FSTSW` (store status word) instruction can be used following a comparison to transfer the condition code to memory for later inspection. (See the instruction reference pages at the end of this chapter for the interpretation of the condition code bits.)

**Table 7-7. Comparison Instructions**

|                      |                                                                                                 |
|----------------------|-------------------------------------------------------------------------------------------------|
| <code>FCOM</code>    | Compare real                                                                                    |
| <code>FCOMP</code>   | Compare real and pop                                                                            |
| <code>FCOMPP</code>  | Compare real and pop twice                                                                      |
| <code>FUCOM</code>   | Unordered compare real (not available on the Intel287 floating-point coprocessor)               |
| <code>FUCOMP</code>  | Unordered compare real and pop (not available on the Intel287 floating-point coprocessor)       |
| <code>FUCOMPP</code> | Unordered compare real and pop twice (not available on the Intel287 floating-point coprocessor) |
| <code>FICOM</code>   | Compare integer                                                                                 |
| <code>FICOMP</code>  | Compare integer and pop                                                                         |
| <code>FTST</code>    | Test                                                                                            |
| <code>FXAM</code>    | Examine                                                                                         |

The basic operations are compare, test (compare with 0), and examine (report sign and classify operand). Special forms of the compare operation optimize algorithms by comparing `ST` directly with binary integers and real numbers in memory.

Many non-comparison floating-point coprocessor instructions also update the status word condition code bits. Use `FSTSW` immediately after a comparison to be sure that the status word is not changed unintentionally.

## Transcendental Instructions

The instructions summarized in Table 7-8 perform the core calculations for all common trigonometric, inverse trigonometric, logarithmic, and exponential functions.

**Table 7-8. Transcendental Instructions**

|         |                                                                            |
|---------|----------------------------------------------------------------------------|
| FSIN    | Sine (not available on the Intel287 floating-point coprocessor)            |
| FCOS    | Cosine (not available on the Intel287 floating-point coprocessor)          |
| FSINCOS | Sine and Cosine (not available on the Intel287 floating-point coprocessor) |
| FPTAN   | Partial tangent                                                            |
| FPATAN  | Partial arctangent                                                         |
| F2XM1   | $2^x - 1$                                                                  |
| FYL2X   | $Y * \log_2 X$                                                             |
| FYL2XP1 | $Y * \log_2(X + 1)$                                                        |

The transcendentals operate on the top one or two stack elements and they return their results to the stack. The instruction descriptions at the end of this chapter specify the operand range for each transcendental.

If a transcendental operand is invalid or out of range, the Intel287 coprocessor may produce an undefined result without signaling an exception. It is the programmer's responsibility to ensure that transcendental operands are valid and in range.

Prologue software can be used to reduce arguments to the range accepted by the transcendental instructions. Epilog software can be used to adjust transcendental results to correspond to the original arguments, *if* necessary, floating-point coprocessor `FPREM` or Intel387 coprocessor `FPREM1` can be used to bring an operand into range for the trigonometric functions.

## Coprocessor Control Instructions

Most instructions shown in Table 7-9 are used in system rather than application software. These activities include: Intel387/Intel287 coprocessor initialization, exception handling, and task switching.

**Table 7-9. Processor Control Instructions**

|                |                                       |
|----------------|---------------------------------------|
| FINIT/FNINIT   | Initialize processor                  |
| FSTCW/FNSTCW   | Store control word                    |
| FLDCW          | Load control word                     |
| FSTSW/FNSTSW   | Store status word                     |
| FCLEX/FNCLEX   | Clear exceptions                      |
| FSTENV/FNSTENV | Store environment                     |
| FLDENV         | Load environment                      |
| FSAVE/FNSAVE   | Store state                           |
| FRSTOR         | Restore state                         |
| FINCSTP        | Increment stack pointer               |
| FDECSTP        | Decrement stack pointer               |
| FFREE          | Free (empty) stack top element        |
| FNOP           | No operation                          |
| FSETPM         | Set Intel286 processor protected mode |
| FWAIT          | Alternate processor WAIT              |

Alternate mnemonics are shown for several processor control instructions in Table 7-9. The alternates with a second character of N instruct the assembler not to prefix the instruction with an automatically generated (F)WAIT. This no-wait form is intended for use in critical code regions where a pending and unmasked exception should not generate an interrupt.

All instructions that provide a no-wait mnemonic are self-synchronizing; they can be executed back-to-back in any combination without intervening (F)WAITS. These instructions can be executed by one part of the floating-point coprocessor while the other part is busy with a previously decoded instruction.

Use the wait forms of these instructions when control should pass to a software exception handler before these instructions execute.

# Floating-point Coprocessor Instruction Set Reference

This section provides a detailed reference for each floating-point instruction available to the Intel386/Intel387 or Intel386/Intel287 processor/coprocessor combinations.

## How to Read the Instruction Set Reference Pages

For each floating-point coprocessor instruction, a table summarizes the opcode, instruction syntax, clocks, and description of its operation. Following the table is a discussion of the instruction and a list of exceptions it may generate. As an example of an instruction table:

| Opcode          | Instruction        | Clocks          |           | Description                    |
|-----------------|--------------------|-----------------|-----------|--------------------------------|
|                 |                    | i387™ NPX       | i287™ NPX |                                |
| D9 C0+ <i>i</i> | FLD ST( <i>i</i> ) | 14              | 17-22     | Push, ST := old ST( <i>i</i> ) |
| D9 /0           | FLD <i>m32r</i>    | 20 <sup>†</sup> | 38-56     | Push, ST := <i>m32r</i>        |
| DD /0           | FLD <i>m64r</i>    | 25 <sup>†</sup> | 40-60     | Push, ST := <i>m64r</i>        |
| DB /5           | FLD <i>m80r</i>    | 44              | 53-65     | Push, ST := <i>m80r</i>        |

<sup>†</sup> Add 5 clocks when loading zero from memory.

The following subsections describe the notation used in each column of these tables and the reference page sections for each instruction.

### Opcode Column

The Opcode column lists the object bytes generated for each form of the instruction. Where possible, the bytes are given in hexadecimal. Code other than hexadecimal is as follows:

*/n* This value goes in the REG/OPCODE field of the ModRM byte (see Figure 6-2). Tables 6-13 and 6-14 show the possible hexadecimal values for the ModRM byte. The column labels show the REG= or /digit(Opcode) associated with the REG field. The row labels show the address form associated with the ModRM byte's other fields. The bottom eight rows of Tables 6-13 and 6-14 do not apply because register forms of the ModRM byte are illegal for floating-point instructions.

*+i* This is the index number of the floating-point stack element (0 is the top element, 1 is the next element, ..., 7 is the last element). *i* is added to the preceding hexadecimal value to form a single opcode byte.

## Instruction Column

The instruction column shows the template for each floating-point instruction as it should appear in the ASM386 source program. Items in italics represent operands that you must specify, as follows:

*ST(i)*        The letter *i* stands for a digit from 1 through 7, indicating which floating-point stack element is the operand. *i* = 0 is legal but redundant.

*m32r, m64r, m80r, m16j, m32j, m64j, m80d*  
Each of these symbols stands for a memory operand. Suffixes *r, j,* and *d* represent "real," "integer," and "binary coded decimal," respectively; *16, 32, 64,* and *80* represent the length in bits of the operand.

*m2by, m14/28by, m94/108by*  
The suffix *by* indicates operand length measured in bytes. *m2by* refers to the address of a 2-byte memory location. *m14/28by* refers to the address of a 14- or 28-byte memory location, respectively; *m94/108by* refers to the location of a 94- or 108-byte location.

If the operand is 16-, 32-, 64-, or 80-bits in length, the memory operand should be declared with DW, DD, DQ, or DT, respectively.

See also:    Types of memory addressing allowed, Chapter 5

## Clocks Columns

The clocks columns give the number of clock cycles each instruction takes to execute on the Intel287 or Intel387 floating-point coprocessor (NPX). A dash (----) in the Intel287 coprocessor column indicates a Intel387 coprocessor-only instruction. Clock count calculations make the following assumptions:

1. The instruction is ready for execution.
2. Bus cycles do not require wait states.
3. There are no floating-point coprocessor data transfers or local bus HOLD requests delaying processor access to the bus.
4. No exceptions are detected during instruction execution.
5. Memory operands are aligned.

## Description Column

The description column contains a concise definition of the operation performed for each form of the instruction.

## Discussion Section

This section describes the instruction's operands, function, and results. It states whether the instruction is available only for the Intel387 coprocessor. It explains any differences between how the Intel287 and Intel387 coprocessors handle the instruction and its operands.

## Exceptions Section

This section lists the exceptions that can occur during instruction execution. If the Intel287 and Intel387 coprocessors generate different exceptions, they are listed separately by coprocessor.

## How to Look Up an Instruction

The floating-point instructions are presented in mnemonic alphabetical order, with the following exceptions:

- Instructions that reverse the operands of a division (`FDIVR`) or subtraction (`FSUBR`) operation are listed with `FDIV` and `FSUB`, respectively.
- Instructions that pop the stack after a comparison are listed with `FCOM` or `FUCOM`. Those that pop the stack after a basic arithmetic operation are listed with `FADD`, `FDIV`, `FMUL`, and `FSUB`.
- Instructions beginning with `FN`, except for `FNOP`, are alternate forms of the instructions without the `N`. They are listed with the non-`N` mnemonics.
- Some instructions beginning with `FLD` load constants into the floating-point stack. They are listed together under `FLDcon`, after the other `FLD` instructions.

Some mnemonics are not included in the instruction pages, even though they are a part of the floating-point instruction set. They are provided to make 8086/8088 programs compatible with the assembler. `FENI`, `FNENI`, `FDISI`, and `FNDISI` are interrupt control instructions on the 8087 that are not needed on the floating-point coprocessor. These instructions are legal, but the assembler generates no floating-point coprocessor object code for them.

The remainder of this chapter consists of the floating-point coprocessor instructions accompanied by descriptive text, listed in alphanumeric order.

## F2XM1 Compute $Y = 2^X - 1$

| Opcode | Instruction | Clocks   |          | Description   |
|--------|-------------|----------|----------|---------------|
|        |             | i387 NPX | i287 NPX |               |
| D9 F0  | F2XM1       | 211-476  | 310-630  | ST := 2ST - 1 |

### Discussion

F2XM1 calculates the function  $Y = 2^X - 1$ . X is taken from the top of the floating-point stack. X must be in the range:

- $-1.0 <= X <= +1.0$  for the Intel387 coprocessor.
- $0 <= X <= +0.5$  for the Intel287 coprocessor.

The result Y replaces X at the stack top.

The instruction is designed to produce an accurate exponential even for inputs very close to 0. The following formulas show how values other than 2 can be raised to a power of X:

- $10^X = 2^{X \cdot \log_2 10}$
- $e^X = 2^{X \cdot \log_2 e}$
- $Y^X = 2^{X \cdot \log_2 Y}$

Floating-point coprocessor instructions (see FLDcon) are available to load the constants  $\log_2 10$  and  $\log_2 e$ . The FYL2X instruction can be used to calculate  $X \cdot \log_2 Y$ .

### Exceptions

#### Intel387 NPX

Invalid, denormalized, underflow, precision

#### Intel287 NPX

Underflow, precision

## FABS Absolute Value

| Opcode | Instruction | Clocks   |          | Description |
|--------|-------------|----------|----------|-------------|
|        |             | i387 NPX | i287 NPX |             |
| D9 E1  | FABS        | 22       | 10-17    | ST :=  ST   |

### Discussion

FABS changes the element in the top of the stack to its absolute value by making its sign positive.

### Exceptions

#### Intel387 NPX

Invalid only for stack overflow/underflow

#### Intel287 NPX

Invalid

**FADD/FADDP** Real Addition

| Opcode  | Instruction      | Clocks   |          | Description                        |
|---------|------------------|----------|----------|------------------------------------|
|         |                  | i387 NPX | i287 NPX |                                    |
| DE C1   | FADD             | 26-34    | 75-105   | ST(1) := ST(1) + ST,<br>pop old ST |
| D8 C0+i | FADD ST,ST(i)    | 23-31    | 70-100   | ST := ST + ST(i)                   |
| DC C0+i | FADD ST(i),ST    | 26-34    | 70-100   | ST(i) := ST(i) + ST                |
| D8 /0   | FADD <i>m32r</i> | 24-32    | 90-120   | ST := ST + <i>m32r</i>             |
| DC /0   | FADD <i>m64r</i> | 29-37    | 95-125   | ST := ST + <i>m64r</i>             |
| DE C0+i | FADDP ST(i),ST   | 26-34    | 75-105   | ST(i) := ST(i) + ST,<br>pop        |

**Discussion**

FADD and FADDP add two floating-point numbers. The two-operand forms of the instructions add the second operand to the first operand and replace the first operand with the sum. The one-operand forms add the operand to the stack top and replace the stack top with the sum.

The FADDP instruction returns a result to ST(i). The FADD instruction with no operands returns a result to ST(1). Both instructions pop the top element (old ST(0)) from the stack when the operation is complete.

**Exceptions**

Invalid, denormalized, overflow, underflow, precision

## FBLD BCD Load to Real

| Opcode | Instruction | Clocks   |          | Description      |
|--------|-------------|----------|----------|------------------|
|        |             | i387 NPX | i287 NPX |                  |
| DF /4  | FBLD m80d   | 266-275  | 290-310  | Push, ST := m80d |

### Discussion

The BCD load instruction converts the memory operand from packed decimal to an extended precision real and pushes the result onto the floating-point coprocessor stack.

FBLD is an exact operation; the floating-point coprocessor loads the BCD operand with no rounding error. The sign of the source operand is preserved, including the case when its value is -0.

The packed decimal digits of the operand are assumed to be in the range 0H through 9H. If the source contains invalid digits (A through F hexadecimal), the result is undefined.

ST(7) must be empty to avoid causing an exception.

### Exceptions

Invalid

## FBSTP BCD Store and Pop

| Opcode | Instruction | Clocks   |          | Description     |
|--------|-------------|----------|----------|-----------------|
|        |             | i387 NPX | i287 NPX |                 |
| DF /6  | FBSTP m80d  | 512-534  | 520-540  | m80d := ST, pop |

### Discussion

FBSTP converts the stack top to a packed decimal integer, stores the result in the memory location indicated by the operand, and pops the stack.

Intel387 coprocessor FBSTP rounds a non-integral value according to the RC (rounding control) field of the Intel387 coprocessor control word. (See Figure 7-5 for control word layout.)

The Intel287 coprocessor adds 0.5 to the input value, then chops away the fractional part to convert such a value to integer. Precede FBSTP with FRNDINT to control the method of rounding by the RC field of the Intel287 coprocessor control word.

### Exceptions

#### Intel387 NPX

Invalid, precision

#### Intel287 NPX

Invalid

## **FCHS** Change Sign of Real Number

| Opcode | Instruction | Cycles   |          | Description |
|--------|-------------|----------|----------|-------------|
|        |             | i387 NPX | i287 NPX |             |
| D9 E0  | FCHS        | 24-25    | 10-17    | ST := -ST   |

### **Discussion**

FCHS reverses the sign of the stack top element.

### **Exceptions**

#### **Intel387 NPX**

Invalid only for stack overflow/underflow

#### **Intel287 NPX**

Invalid

## FCLEX/FNCLEX Clear Floating-point Coprocessor Exceptions

| Opcode   | Instruction | Clocks          |                  | Description                                                            |
|----------|-------------|-----------------|------------------|------------------------------------------------------------------------|
|          |             | i387 NPX        | i287 NPX         |                                                                        |
| 9B DB E2 | FCLEX       | 11 <sup>†</sup> | 2-8 <sup>†</sup> | Clear exceptions after check for pending unmasked floating-point error |
| DB E2    | FNCLEX      | 11              | 2-8              | Clear exceptions without check for floating-point error                |

<sup>†</sup> Add at least 6 clocks for automatic FWAIT.

### Discussion

FCLEX and FNCLEX clear all floating-point coprocessor exception flags and the busy bit in the status word. FCLEX/FNCLEX also clears the floating-point coprocessor exception status bit. As a consequence, the ERROR# line goes inactive.

An assembler-generated WAIT instruction precedes the FCLEX form of this instruction. It is used when a pending unmasked numeric error should be serviced before clearing the exceptions.

FNCLEX is used in critical areas of code where a pending unmasked numeric error cannot be allowed to generate an interrupt.

### Exceptions

None

**FCOM/FCOMP/FCOMPP** Compare Real Numbers

| Opcode          | Instruction          | Clocks   |          | Description                            |
|-----------------|----------------------|----------|----------|----------------------------------------|
|                 |                      | i387 NPX | i287 NPX |                                        |
| D8 D1           | FCOM                 | 24       | 40-50    | Compare ST with ST(1)                  |
| D8 D0+ <i>i</i> | FCOM ST( <i>i</i> )  | 24       | 40-50    | Compare ST with ST( <i>i</i> )         |
| D8 /2           | FCOM <i>m32r</i>     | 26       | 60-70    | Compare ST with <i>m32r</i>            |
| DC /2           | FCOM <i>m64r</i>     | 31       | 65-75    | Compare ST with <i>m64r</i>            |
| D8 D9           | FCOMP                | 26       | 45-52    | Compare ST with<br>ST(1), pop          |
| D8 D8+ <i>i</i> | FCOMP ST( <i>i</i> ) | 26       | 45-52    | Compare ST with ST( <i>i</i> ),<br>pop |
| D8 /3           | FCOMP <i>m32r</i>    | 26       | 63-73    | Compare ST with <i>m32r</i> ,<br>pop   |
| DC /3           | FCOMP <i>m64r</i>    | 31       | 67-77    | Compare ST with <i>m64r</i> ,<br>pop   |
| DE D9           | FCOMPP               | 26       | 45-55    | Compare ST with<br>ST(1), pop twice    |

## Discussion

The `FCOM` instructions compare the stack top to the source operand. After making the comparison, `FCOMP` pops the top element from the stack. After comparing the top two stack elements, `FCOMPP` pops both of them.

There are four possible results to the comparison of two real numbers. Three are greater than, less than, and equals. The fourth, unordered (not comparable) occurs when one of the compared quantities is a NaN, an unsupported Intel387 coprocessor format, or an Intel287 coprocessor projective infinity.

`FCOM/FCOMP/FCOMPP` ignores the sign of zero:  $-0.0 = +0.0$ .

The flags C3, C2, and C0 (bits 14, 10, and 8, respectively) of the floating-point coprocessor status word indicate the result of an `FCOM` comparison, as shown in the Table 7-10.

To test these bits, load them into the processor flags register by following `FCOM` with the following instruction sequence:

```

FSTSW AX      ; store status word in AX
SAHF          ; bits are now stored in
              ; zero, parity, and carry flags
JPE UNORDR   ; JUMP if the result was unordered
    
```

Table 7-10. Condition Code after FCOM(P/PP)

| Order        | (ZF)<br>C3 | (PF)<br>C2 | (CF)<br>C0 | Processor<br>Conditional Branch |
|--------------|------------|------------|------------|---------------------------------|
| ST > Operand | 0          | 0          | 0          | JA                              |
| ST < Operand | 0          | 0          | 1          | JB                              |
| ST = Operand | 1          | 0          | 0          | JE                              |
| Unordered    | 1          | 1          | 1          | JP                              |

Conditional jumps can now be made, using the below (JB), above (JA), and equal (JE) mnemonics.

## Exceptions

Invalid, denormalized

## FCOS Compute $Y = \cos(X)$

| Opcode | Instruction | Clocks               |          | Description   |
|--------|-------------|----------------------|----------|---------------|
|        |             | i387 NPX             | i287 NPX |               |
| D9 FF  | FCOS        | 123-772 <sup>†</sup> | -----    | ST := cos(ST) |

<sup>†</sup> Add up to 76 clocks when  $|ST| \geq \pi/4$ .

### Discussion

FCOS replaces the contents of ST with  $\cos(ST)$ . ST must be an angle expressed in radians and it must lie in the range  $|ST| < (\pi/4 * 2^{63})$ . Pi is the Intel387 coprocessor's 67-bit approximation to true pi.

If ST is in range, C2 of the Intel387 coprocessor status word is cleared and the result of the operation is produced. Otherwise, C2 is set to 1 (function incomplete) and the operand value of ST remains intact.

It is the programmer's responsibility to reduce the operand to an absolute value less than  $(\pi/4 * 2^{63})$ . Use FPREM1 or FPREM if it is necessary to bring ST into range.

FCOS is a Intel387 coprocessor instruction; it is not available for a Intel287 coprocessor.

### Exceptions

Invalid, denormalized, underflow, precision

## FDECSTP Decrement Floating-point Stack Pointer

| Opcode | Instruction | Clocks   |          | Description                 |
|--------|-------------|----------|----------|-----------------------------|
|        |             | i387 NPX | i287 NPX |                             |
| D9 F6  | FDECSTP     | 22       | 6-12     | Decrement stack_top pointer |

### Discussion

FDECSTP subtracts 1 from the stack top pointer (TOP) of the floating-point coprocessor status word. No tags or registers are altered, nor is any data transferred. Executing FDECSTP when the stack top pointer is 0 changes the pointer to 7.

The effect of FDECSTP ST is to rotate the stack. Instead of something being pushed onto the stack, the new stack top contains the contents of the former ST(7).

### Exceptions

None

**FDIV/FDIVP/FDIVR/FDIVRP** Real Divide/Real Reverse Divide

| Opcode  | Instruction       | Clocks   |          | Description                        |
|---------|-------------------|----------|----------|------------------------------------|
|         |                   | i387 NPX | i287 NPX |                                    |
| DE F9   | FDIV              | 91       | 197-207  | ST(1) := ST(1) / ST,<br>pop old ST |
| DC F8+i | FDIV ST(i),ST     | 91       | 193-203  | ST(i) := ST(i) / ST                |
| D8 F0+i | FDIV ST,ST(i)     | 88       | 193-203  | ST := ST / ST(i)                   |
| D8 /6   | FDIV <i>m32r</i>  | 89       | 215-225  | ST := ST / <i>m32r</i>             |
| DC /6   | FDIV <i>m64r</i>  | 94       | 220-230  | ST := ST / <i>m64r</i>             |
| DE F8+i | FDIVP ST(i),ST    | 91       | 197-207  | ST(i) := ST(i) / ST,<br>pop        |
| DE F1   | FDIVR             | 91       | 198-208  | ST(1) := ST / ST(1),<br>pop old ST |
| DC F0+i | FDIVR ST(i),ST    | 91       | 194-204  | ST(i) := ST / ST(i)                |
| D8 F8+i | FDIVR ST,ST(i)    | 88       | 194-204  | ST := ST(i) / ST                   |
| D8 /7   | FDIVR <i>m32r</i> | 89       | 216-226  | ST := <i>m32r</i> / ST             |
| DC /7   | FDIVR <i>m64r</i> | 94       | 221-231  | ST := <i>m64r</i> / ST             |
| DE F0+i | FDIVRP ST(i),ST   | 91       | 198-208  | ST(i) := ST / ST(i),<br>pop        |

## Discussion

FDIV, FDIVP, FDIVR, and FDIVRP divide two floating-point numbers.

The two-operand forms of the FDIV/FDIVP instructions divide the first operand (dividend) by the second operand (divisor). FDIV/FDIVP replace the dividend with the result. The one-operand forms divide the stack top by the operand and replace the stack top with the result.

The two-operand forms of the FDIVR/FDIVRP instructions divide the second operand by the first. FDIVR/FDIVRP replace the divisor with the result. The one-operand forms divide the operand by the stack top and replace the stack top with the result.

The FDIVP/FDIVRP instructions return a result to ST(i). The FDIV/FDIVR instructions with no operands return a result to ST(1). These instructions pop the top element (old ST(0)) from the stack when the operation is complete.

## Exceptions

Invalid, denormalized, zerodivide, overflow, underflow, precision

**FFREE** Free Floating-point Stack Entry

| Opcode  | Instruction  | Clocks   |          | Description  |
|---------|--------------|----------|----------|--------------|
|         |              | i387 NPX | i287 NPX |              |
| DD C0+i | FFREE ST(i ) | 18       | 9-16     | Empty ST(i ) |

**Discussion**

FFREE changes the tag of the operand stack element to empty. The contents of this stack element are unaffected. The floating-point stack pointer (TOP) is also unaffected.

**Exceptions**

None

## FIADD Integer Add to Real

| Opcode | Instruction       | Cycles   |          | Description            |
|--------|-------------------|----------|----------|------------------------|
|        |                   | i387 NPX | i287 NPX |                        |
| DE /0  | FIADD <i>m16j</i> | 71-85    | 102-137  | ST := ST + <i>m16j</i> |
| DA /0  | FIADD <i>m32j</i> | 57-72    | 108-143  | ST := ST + <i>m32j</i> |

### Discussion

FIADD adds the integer memory operand into the element on top of the stack. It replaces the top of the stack with the result.

### Exceptions

#### Intel387 NPX

Invalid, denormalized, overflow, underflow if integer 0 is added to a denormal when underflow is unmasked, precision

#### Intel287 NPX

Invalid, denormalized, overflow, precision

**FICOM/FICOMP** Integer Compare with Real

| Opcode | Instruction        | Clocks   |          | Description                          |
|--------|--------------------|----------|----------|--------------------------------------|
|        |                    | i387 NPX | i287 NPX |                                      |
| DE /2  | FICOM <i>m16j</i>  | 71-75    | 72-86    | Compare ST with <i>m16j</i>          |
| DA /2  | FICOM <i>m32j</i>  | 56-63    | 78-91    | Compare ST with <i>m32j</i>          |
| DE /3  | FICOMP <i>m16j</i> | 71-75    | 74-88    | Compare ST with <i>m16j</i> ,<br>pop |
| DA /3  | FICOMP <i>m32j</i> | 56-63    | 80-93    | Compare ST with <i>m32j</i> ,<br>pop |

**Discussion**

FICOM and FICOMP convert the memory operand (a word or short integer) internally to extended precision real and compare it with the top of the stack. The FICOMP instruction pops the top stack element after the comparison is made.

There are four possible results to the comparison of two real numbers. Three are greater than, less than, and equals. The fourth, unordered or not comparable, occurs when ST is a NaN, an unsupported Intel387 coprocessor format, or an Intel287 coprocessor projective infinity. FICOM/FICOMP ignores the sign of zero: -0.0 = +0.0.

The flags C3, C2, and C0 (bits 14, 10, and 8, respectively) of the floating-point coprocessor status word indicate the result of an FICOM/FICOMP comparison, as shown in Table 7-11.

**Table 7-11. Condition Code after FICOM(P)**

| Order        | (ZF)<br>C3 | (PF)<br>C2 | (CF)<br>C0 | Processor<br>Conditional Branch |
|--------------|------------|------------|------------|---------------------------------|
| ST > Operand | 0          | 0          | 0          | JA                              |
| ST < Operand | 0          | 0          | 1          | JB                              |
| ST = Operand | 1          | 0          | 0          | JE                              |
| Unordered    | 1          | 1          | 1          | JP                              |

## FICOM/FICOMP

---

To test these bits, load them into the processor flags register by following FICOM with the following instruction sequence:

```
FSTSW AX      ; store status word in AX
SAHF          ; bits are now stored in
              ; zero, parity, and carry flags
JPE UNORDR    ; JUMP if the result was unordered
```

Conditional jumps can now be made, using the below (JB), above (JA), and equal (JE) mnemonics.

### Exceptions

Invalid, denormalized

## FIDIV/FIDIVR Integer Divide into Real

| Opcode | Instruction        | Clocks   |          | Description            |
|--------|--------------------|----------|----------|------------------------|
|        |                    | i387 NPX | i287 NPX |                        |
| DE /6  | FIDIV <i>m16j</i>  | 136-140  | 224-238  | ST := ST / <i>m16j</i> |
| DA /6  | FIDIV <i>m32j</i>  | 120-127  | 230-243  | ST := ST / <i>m32j</i> |
| DE /7  | FIDIVR <i>m16j</i> | 137-141  | 225-239  | ST := <i>m16j</i> / ST |
| DA /7  | FIDIVR <i>m32j</i> | 121-128  | 231-245  | ST := <i>m32j</i> / ST |

### Discussion

FIDIV divides the top of the stack by the integer memory operand. The answer replaces the dividend on the top of the stack.

FIDIVR performs the reverse divide: the integer memory operand is divided by the top of the stack. The answer replaces the divisor on the top of the stack.

### Exceptions

Invalid, zerodivide, denormalized, (FIDIVR) overflow, underflow, precision

**FILD** Integer Load into Real

| <b>Opcode</b> | <b>Instruction</b> | <b>Clocks</b>   |                 | <b>Description</b> |
|---------------|--------------------|-----------------|-----------------|--------------------|
|               |                    | <b>i387 NPX</b> | <b>i287 NPX</b> |                    |
| DF /0         | FILD m16j          | 61-65           | 46-64           | Push, ST := m16j   |
| DB /0         | FILD m32j          | 45-52           | 52-60           | Push, ST := m32j   |
| DF /5         | FILD m64j          | 56-67           | 60-68           | Push, ST := m64j   |

**Discussion**

FILD converts the integer memory operand from its binary integer format (word, short, or long) to an extended precision real and pushes the result onto the stack.

ST(7) must be empty to avoid causing an exception.

**Exceptions**

Invalid

## FIMUL Integer Multiply with Real

| Opcode | Instruction       | Clocks   |          | Description            |
|--------|-------------------|----------|----------|------------------------|
|        |                   | i387 NPX | i287 NPX |                        |
| DE /1  | FIMUL <i>m16j</i> | 76-87    | 124-138  | ST := ST * <i>m16j</i> |
| DA /1  | FIMUL <i>m32j</i> | 61-82    | 130-144  | ST := ST * <i>m32j</i> |

### Discussion

FIMUL multiplies the integer memory operand into the top of the stack. The product replaces the multiplicand on the top of the stack.

### Exceptions

#### Intel387 NPX

Invalid, denormalized, overflow, unmasked underflow, precision

#### Intel287 NPX

Invalid, denormalized, overflow, precision

## FINCSTP Increment Floating-point Stack Pointer

| Opcode | Instruction | Clocks   |          | Description                 |
|--------|-------------|----------|----------|-----------------------------|
|        |             | i387 NPX | i287 NPX |                             |
| D9 F7  | FINCSTP     | 21       | 6-12     | Increment stack_top pointer |

### Discussion

FINCSTP adds 1 to the stack top pointer (TOP) of the floating-point coprocessor status word. It does not alter any tags or registers, nor does it transfer data. Executing FINCSTP when the stack top pointer is 7 changes it to 0.

FINCSTP rotates the stack, but it is not equivalent to popping the stack. It does not set the tag of the previous stack top to empty, and the former stack top becomes ST(7).

### Exceptions

None

## FINIT/FNINIT Initialize Floating-point Coprocessor

| Opcode   | Instruction | Clocks          |                  | Description                                                                                  |
|----------|-------------|-----------------|------------------|----------------------------------------------------------------------------------------------|
|          |             | i387 NPX        | i287 NPX         |                                                                                              |
| 9B DB E3 | FINIT       | 33 <sup>†</sup> | 2-8 <sup>†</sup> | Initialize floating-point coprocessor after check for pending unmasked floating-point errors |
| DB E3    | FNINIT      | 33              | 2-8              | Initialize floating-point coprocessor without check for floating-point errors                |

<sup>†</sup> Add at least 6 clocks for automatic FWAIT.

### Discussion

FINIT/FNINIT sets the floating-point coprocessor into a known state, unaffected by any previous activity.

FINIT/FNINIT is not quite the functional equivalent of a hardware RESET:

- For the Intel387 coprocessor, RESET causes the IM bit of the control word to be zeroed and the ES and IE bits of the status word to be set (1) in order to signal the presence of an Intel387 coprocessor. FINIT/FNINIT puts the opposite values in these 3-bits.
- For the Intel287 coprocessor, RESET initializes the coprocessor in real address mode. FINIT/FNINIT does not affect the current operating mode (real address or protected mode).

The FNINIT form of this instruction aborts the floating-point coprocessor bus cycles in progress if a preceding memory-referencing instruction is running.

FNINIT may be necessary to clear the floating-point coprocessor if the processor detects an interrupt 9 (a processor extension segment overrun exception).

Table 7-12 summarizes the effect of FINIT/FNINIT for both the Intel387 and Intel287 coprocessors.

**Table 7-12. Floating-point Coprocessor State Following FINIT/FNINIT**

| Field                 | Value    |          | Interpretation                                                      |
|-----------------------|----------|----------|---------------------------------------------------------------------|
|                       | i387 NPX | i287 NPX |                                                                     |
| Control Word:         |          |          |                                                                     |
| Infinity <sup>†</sup> | 1        | 0        | 387 NPX: Affine <sup>†</sup> ; i287 NPX: Projective                 |
| Rounding              | 00       | 00       | Round to nearest                                                    |
| Precision             | 11       | 11       | 64-bits                                                             |
| Exception Masks       | 111111   | 111111   | All exceptions masked                                               |
| Status Word:          |          |          |                                                                     |
| Busy                  | 0        | 0        | i387 NPX: Reflects the Exception Status setting; i287 NPX: not busy |
| Condition Code        | ????     | ????     | Indeterminate                                                       |
| Stack Top             | 000      | 000      | stack_register (0) = TOP                                            |
| Exception Status      | 0        | 0        | No exceptions                                                       |
| Stack Flag            | 0        | ††       | i387 NPX: -                                                         |
| Exception Flags       | 000000   | 000000   | No exceptions                                                       |
| Tag Word:             |          |          |                                                                     |
| Tags                  | 11       | 11       | Empty                                                               |
| Registers             | n.c.     | n.c.     | Not changed                                                         |
| Exception Pointers:   |          |          |                                                                     |
| Instruction Code      | n.c.     | n.c.     | Not changed                                                         |
| Instruction Address   | n.c.     | n.c.     | Not changed                                                         |
| Operand Address       | n.c.     | n.c.     | Not changed                                                         |

<sup>†</sup> The Intel387 floating-point coprocessor has IEEE 754 infinity closure. This value is listed to emphasize that programs written for the Intel287 floating-point coprocessor may not behave the same on the Intel387 floating-point coprocessor if they depend on this bit.

<sup>††</sup> The Intel287 floating-point coprocessor status word does not use this field.

## Exceptions

None

## FIST/FISTP Integer Store from Real

| Opcode | Instruction       | Clocks   |          | Description            |
|--------|-------------------|----------|----------|------------------------|
|        |                   | i387 NPX | i287 NPX |                        |
| DF /2  | FIST <i>m16j</i>  | 82-95    | 80-90    | <i>m16j</i> := ST      |
| DB /2  | FIST <i>m32j</i>  | 79-93    | 82-92    | <i>m32j</i> := ST      |
| DF /3  | FISTP <i>m16j</i> | 82-95    | 82-92    | <i>m16j</i> := ST, pop |
| DB /3  | FISTP <i>m32j</i> | 79-93    | 84-94    | <i>m32j</i> := ST, pop |
| DF /7  | FISTP <i>m64j</i> | 80-97    | 94-105   | <i>m64j</i> := ST, pop |

### Discussion

FIST rounds the stack top to an integer according to the RC field of the floating-point coprocessor control word. It then transfers the result to the memory destination indicated by the operand.

FISTP is identical to FIST except that the stack top is popped after the operand is stored.

The FIST/FISTP operand may define a word or a short integer variable. Only FISTP stores a long integer. Negative zero is stored in the same encoding as positive zero: all bits are 0.

### Exceptions

Invalid, underflow if ST is empty, precision

**FISUB/FISUBR** Integer Subtract from Real

| Opcode | Instruction        | Clocks   |          | Description            |
|--------|--------------------|----------|----------|------------------------|
|        |                    | i387 NPX | i287 NPX |                        |
| DE /4  | FISUB <i>m16j</i>  | 71-83    | 102-137  | ST := ST - <i>m16j</i> |
| DA /4  | FISUB <i>m32j</i>  | 57-82    | 108-143  | ST := ST - <i>m32j</i> |
| DE /5  | FISUBR <i>m16j</i> | 72-84    | 103-139  | ST := <i>m16j</i> - ST |
| DA /5  | FISUBR <i>m32j</i> | 58-83    | 109-144  | ST := <i>m32j</i> - ST |

**Discussion**

FISUB subtracts the integer memory operand (subtrahend) from the top of the stack. The answer replaces the minuend on the top of the stack.

FISUBR performs the reverse subtraction: the stack top is subtracted from the integer memory operand, and the answer replaces the subtrahend on the top of the stack.

**Exceptions****Intel387 NPX**

Invalid, denormalized, overflow, unmasked underflow, precision

**Intel287 NPX**

Invalid, denormalized, overflow, precision

**FLD** Load Real

| Opcode  | Instruction        | Clocks          |          | Description                    |
|---------|--------------------|-----------------|----------|--------------------------------|
|         |                    | i387 NPX        | i287 NPX |                                |
| D9 C0+i | FLD ST( <i>i</i> ) | 14              | 17-22    | Push, ST := old ST( <i>i</i> ) |
| D9 /0   | FLD <i>m32r</i>    | 20 <sup>†</sup> | 38-56    | Push, ST := <i>m32r</i>        |
| DD /0   | FLD <i>m64r</i>    | 25 <sup>†</sup> | 40-60    | Push, ST := <i>m64r</i>        |
| DB /5   | FLD m80r           | 44              | 53-65    | Push, ST := m80r               |

<sup>†</sup> Add 5 clocks when loading zero from memory.

**Discussion**

FLD pushes the source operand onto the top of the floating-point stack. This is done by decrementing the stack pointer by 1 and then copying the value of the source to the new stack top.

The source can be an element on the stack or any of the real data types in memory. FLD converts single and double precision real operands to extended precision real automatically.

FLD ST(0) duplicates the old stack top in the new stack top. ST(7) must be empty whenever ST is loaded to avoid causing an invalid (stack overflow) exception.

If the denormal exception is masked, the Intel387 coprocessor converts a denormalized single or double precision real operand to extended precision real. It raises an invalid exception when loading a signaling NaN.

The Intel287 coprocessor converts a denormal operand to an unnormal. It does not raise an invalid exception when loading a signaling NaN.

**Exceptions****Intel387 NPX**

Invalid, unmasked denormalized (except when loading an extended precision real)

**Intel287 NPX**

Invalid, denormalized (except when loading an extended precision real)

## FLDCW Load Floating-point Coprocessor Control Word

| Opcode | Instruction | Clocks   |          | Description          |
|--------|-------------|----------|----------|----------------------|
|        |             | i387 NPX | i287 NPX |                      |
| D9 /5  | FLDCW m2by  | 19       | 7-14     | Control_word := m2by |

### Discussion

FLDCW replaces the current floating-point coprocessor control word with the word defined by the source operand. Use FLDCW to establish or change the floating-point coprocessor mode of operation.

If an exception bit in the status word is set, loading a new control word that un masks the exception activates the ERROR# output.

When changing the floating-point coprocessor exception masks be careful about unmasking pending exceptions.

### Exceptions

None, except for unmasking an existing exception

## FLDENV Load Floating-point Coprocessor Environment

| Opcode | Instruction     | Clocks   |          | Description                   |
|--------|-----------------|----------|----------|-------------------------------|
|        |                 | i387 NPX | i287 NPX |                               |
| D9 /4  | FLDENV m14/28by | 71       | 35-45    | Environment := m14by or m28by |

### Discussion

FLDENV loads the floating-point coprocessor environment from the 14- or 28-byte memory area indicated by the operand. The `USE` attribute of the current code segment determines the size of the operand:

- The 14-byte operand applies to a `USE16` segment.
- The 28-byte operand applies to a `USE32` segment.

This data should have been written to by a previous `FSTENV` instruction.

The floating-point coprocessor environment consists of the entire state of the processor, except for the elements of the floating-point stack.

FLDENV waits for all data transfers to complete before executing the next instruction. If the environment image contains an unmasked exception, it causes a numeric exception when the next `(F) WAIT` or exception-checking numeric instruction executes.

### Exceptions

None, except for unmasking an existing exception

## FLDcon Load Real Constant

| Opcode | Instruction | Clocks   |          | Description                 |
|--------|-------------|----------|----------|-----------------------------|
|        |             | i387 NPX | i287 NPX |                             |
| D9 E8  | FLD1        | 24       | 15-21    | Push, ST := +1.0            |
| D9 EA  | FLDL2E      | 40       | 15-21    | Push, ST := $\log_2(e)$     |
| D9 E9  | FLDL2T      | 40       | 16-22    | Push, ST := $\log_{10}(10)$ |
| D9 EC  | FLDLG2      | 41       | 18-24    | Push, ST := $\log_{10}(2)$  |
| D9 ED  | FLDLN2      | 41       | 17-23    | Push, ST := $\log_e(2)$     |
| D9 EB  | FLDPI       | 40       | 16-22    | Push, ST := p               |
| D9 EE  | FLDZ        | 20       | 11-17    | Push, ST := +0.0            |

### Discussion

These instructions push various constant values onto the top of the floating-point stack. Each constant is an extended precision real.

Use the `FLDcon` instructions to save storage and improve execution speed. The same constants in memory require 10 bytes of storage plus access time, while the `FLDcon` are 2-byte instructions.

The Intel387 coprocessor stores these constants in a format even more precise than extended precision real format (accurate to approximately 19 decimal digits). It rounds these constants according to the RC field (bits 10 and 11) of the Intel387 coprocessor control word. Set the Intel387 coprocessor RC field to 00 (round to nearest with even preferred) to obtain `FLDcon` values identical to those of the Intel287 coprocessor.

For the Intel287 coprocessor, the constants 0.0 and 1.0 are exact. All others have full extended precision and are accurate to approximately 19 decimal digits. The rounding control is not in effect.

### Exceptions

Invalid

**FMUL/FMULP** Multiply Real

| Opcode  | Instruction      | Clocks   |          | Description                        |
|---------|------------------|----------|----------|------------------------------------|
|         |                  | i387 NPX | i287 NPX |                                    |
| DE C9   | FMUL             | 29-57    | 95-150   | ST(1) := ST(1) * ST,<br>pop old ST |
| D8 C8+i | FMUL ST,ST(i)    | 46-54    | 90-145   | ST := ST * ST(i)                   |
| DC C8+i | FMUL ST(i),ST    | 29-57    | 90-145   | ST(i) := ST(i) * ST                |
| D8 /1   | FMUL <i>m32r</i> | 27-35    | 110-125  | ST := ST * <i>m32r</i>             |
| DC /1   | FMUL <i>m64r</i> | 32-57    | 112-168  | ST := ST * <i>m64r</i>             |
| DE C8+i | FMULP ST(i),ST   | 29-57    | 95-150   | ST(i) := ST(i) * ST,<br>pop        |

**Discussion**

FMUL and FMULP multiply two floating-point numbers. The two-operand forms of the instructions multiply the second operand into the first operand and replace the first operand with the result. The one-operand forms multiply the operand into the stack top and replace the stack top with the result.

The FMULP instruction returns a result to ST(i). The FMUL instruction with no operands returns a result to ST(1). These instructions pop the top element (old ST(0)) from the stack when the operation is complete.

**Exceptions**

Invalid, denormalized, overflow, underflow, precision

## FNOP

---

### FNOP No Operation

| Opcode | Instruction | Clocks   |          | Description  |
|--------|-------------|----------|----------|--------------|
|        |             | i387 NPX | i287 NPX |              |
| D9 D0  | FNOP        | 12       | 10-16    | No operation |

### Discussion

In effect, `FNOP` performs no operation. The processor instruction pointer is incremented.

### Exceptions

None

## FPATAN Compute R = Partial Arctangent

| Opcode | Instruction | Clocks   |          | Description                             |
|--------|-------------|----------|----------|-----------------------------------------|
|        |             | i387 NPX | i287 NPX |                                         |
| D9 F3  | FPATAN      | 314-487  | 250-800  | ST(1) := arctan(ST(1) / ST), pop old ST |

### Discussion

FPATAN computes the function  $R = \text{ARCTAN}(Y/X)$ .  $X$  is the top stack element, and  $Y$  is the next stack element, ST(1). ( $Y$  is pushed first.) After the function is computed, the floating-point stack is popped once and the answer replaces the former ST(1) on the top of the stack.

For the Intel387 coprocessor, the range of operands is unrestricted. The octant of the result depends on the relationship between the operands:

**Table 7-13. FPATAN Final Result Octant**

| Atan of Y/X<br>Final Result       | Sign<br>Y | Sign<br>X | ??<br> Y  <  X |
|-----------------------------------|-----------|-----------|----------------|
| $0 < \text{atan} < \pi/4$         | +         | +         | yes            |
| $\pi/4 < \text{atan} < \pi/2$     | +         | +         | no             |
| $\pi/2 < \text{atan} < 3*\pi/4$   | +         | -         | no             |
| $3*\pi/4 < \text{atan} < \pi$     | +         | -         | yes            |
| $-\pi/4 < \text{atan} < 0$        | -         | +         | yes            |
| $-\pi/2 < \text{atan} < -\pi/4$   | -         | +         | no             |
| $-3*\pi/4 < \text{atan} < -\pi/2$ | -         | -         | no             |
| $-\pi < \text{atan} < -3*\pi/4$   | -         | -         | yes            |

For the Intel287 coprocessor,  $Y$  and  $X$  must satisfy the inequality  $0 < Y < X < +\infty$ . FPATAN does not check for compliance with the inequality. If this inequality does not hold, results are undefined.

## **FPATAN**

---

### **Exceptions**

#### **Intel387 NPX**

Invalid, denormalized, overflow, underflow, precision

#### **Intel287 NPX**

Underflow, precision

## FPREM/FPREM1 Partial Remainder

| Opcode | Instruction | Clocks   |          | Description                                            |
|--------|-------------|----------|----------|--------------------------------------------------------|
|        |             | i387 NPX | i287 NPX |                                                        |
| D9 F8  | FPREM       | 74-155   | 15-190   | ST := remainder<br>( integer_chop<br>( ST / ST(1) ) )  |
| D9 F5  | FPREM1      | 95-185   | -----    | ST := remainder<br>( integer_round<br>( ST / ST(1) ) ) |

### Discussion

FPREM and FPREM1 perform modulo division of ST by ST(1) and leave the result in ST. The result is always exact; the rounding control has no effect.

If the difference between the FPREM/FPREM1 operands' exponents is less than 64, the function is complete; bit C2 of the floating-point coprocessor status word condition code is cleared to 0. If the function is incomplete, C2 is set to 1 and the result in ST is called the partial remainder. (See Figure 7-4 for status word layout.)

Software can inspect C2 by storing the status word following the execution of FPREM/FPREM1 and reexecuting the instruction (using the partial remainder as the dividend) until C2 is cleared. When this occurs, FPREM/FPREM1 stores the least-significant 3-bits of the quotient in C3, C1, and C0 of the floating-point coprocessor status word. For Intel287 coprocessor FPREM, take care that the final reduction has an operand large enough to generate values in all 3-bits.

FPREM1 is available only for a Intel387 coprocessor; FPREM is available for both the Intel387 and Intel287 coprocessors. FPREM1 differs from FPREM as follows:

- FPREM1 is compatible with the IEEE 754 standard.
- The C3, C1, and C0 settings of the floating-point coprocessor status word (low-order 3-bits of the quotient) may differ by 1 in some cases.
- FPREM1 yields a remainder R1 such that  $-|ST(1)|/2 < R1 < +|ST(1)|/2$ . FPREM yields a remainder R such that  $0 \leq R < |ST(1)|$  or  $-|ST(1)| < R < 0$ , depending on the sign of the dividend.

When the FPREM/FPREM1 operands differ greatly in magnitude, obtaining an exact remainder could seriously increase interrupt latency. For this reason, FPREM/FPREM1 are designed to be coded in a software-controlled loop. The following loop executes FPREM1 until the modulus is complete. A context switch between the instructions in this loop could be forced by an interrupting routine with higher priority.

```

REMLOOP:
    FPREM1          ; reduce ST modulo ST(1)
    FSTSW AX       ; store the status word in AX
    SAHF           ; C2 bit is now stored
                  ; in the parity flag
    JPE REMLOOP    ; loop for repeated
                  ; execution if C2 is 1
    
```

An important use of FPREM/FPREM1 is to reduce trigonometric arguments to operands in the range permitted by the floating-point coprocessor trigonometric instructions. Because FPREM/FPREM1 produces an exact result, argument reduction does not introduce roundoff error even if many iterations are needed to bring an argument into range.

When the FPREM/FPREM1 function is complete, it stores the least significant 3-bits of the quotient in C3, C1, C0 of the floating-point coprocessor status word, as shown in Table 7-14. This is also important for trigonometric argument reduction because it locates the original angle in the correct octant of the unit circle.

**Table 7-14. Condition Code after FPREM/FPREM1**

| (Q1)<br>C3 | Condition Code |            |            | Interpretation after<br>i387 NPX FPREM/FPREM1<br>and after i287 NPX FPREM       |
|------------|----------------|------------|------------|---------------------------------------------------------------------------------|
|            | (PF)<br>C2     | (Q0)<br>C1 | (Q2)<br>C0 |                                                                                 |
| X          | 1              | X          | X          | Incomplete reduction; further iteration needed                                  |
| X          | 0              | X          | X          | Complete reduction; C3, C1, C0 contain low-order bits of quotient (Q1, Q0, Q2): |
| 0          | 0              | 0          | 0          | (Quo) MOD 8 = 0                                                                 |
| 0          | 0              | 1          | 0          | (Quo) MOD 8 = 1                                                                 |
| 1          | 0              | 0          | 0          | (Quo) MOD 8 = 2                                                                 |
| 1          | 0              | 1          | 0          | (Quo) MOD 8 = 3                                                                 |
| 0          | 0              | 0          | 1          | (Quo) MOD 8 = 4                                                                 |
| 0          | 0              | 1          | 1          | (Quo) MOD 8 = 5                                                                 |
| 1          | 0              | 0          | 1          | (Quo) MOD 8 = 6                                                                 |
| 1          | 0              | 1          | 1          | (Quo) MOD 8 = 7                                                                 |

**Exceptions****Intel387 NPX**

Invalid, denormalized, unmasked underflow

**Intel287 NPX**

Invalid, denormalized, underflow

## FPTAN Compute Y = Partial Tan(X)

| Opcode | Instruction | Clocks               |          | Description                                 |
|--------|-------------|----------------------|----------|---------------------------------------------|
|        |             | i387 NPX             | i287 NPX |                                             |
| D9 F2  | FPTAN       | 191-497 <sup>†</sup> | 30-540   | Y / X := tan(ST),<br>ST := Y, push, ST := X |

<sup>†</sup> Add up to 76 clocks when  $|ST| > \pi/4$ .

### Discussion

FPTAN computes the function  $Y / X = \tan(ST)$ . The implicit operand ST must be expressed in radians. The result is a ratio. Y replaces old ST in the stack and X is pushed, becoming the new stack top.

For the Intel387 coprocessor, ST must be less than  $(\pi/4 * 2^{63})$ . When  $\pi/4 \leq |ST| < (\pi/4 * 2^{63})$ , FPTAN reduces ST to a value less than  $\pi/4$  using an internally stored  $\pi/4$  divisor with 67 significant bits. For values of  $ST > (\pi/4 * 2^{63})$ , use FPREM/FPREM1 to reduce ST to the range of FPTAN.

For the Intel287 coprocessor, ST must be in the range  $0 \leq ST \leq \pi/4$ . If ST is not within the correct range or is not normalized, the result is undefined; FPTAN does not issue an exception for out of range input. Use FPREM and the 64-bit constant  $\pi$  (see FLDPI with the FLDcon instructions) to reduce ST to the range of FPTAN.

When FPTAN's argument is within range, it computes Y and X such that  $Y/X = \tan(ST)$ . Y replaces ST. Then, X is pushed, becoming the new stack top. The Intel387 coprocessor pushes  $X = 1$ , so ST(1) contains the tangent of the original operand.

### Exceptions

#### Intel387 NPX

Invalid, denormalized, underflow, precision

#### Intel287 NPX

Invalid, precision

## FRNDINT Round to Integer

| Opcode | Instruction | Clocks   |          | Description     |
|--------|-------------|----------|----------|-----------------|
|        |             | i387 NPX | i287 NPX |                 |
| D9 FC  | FRNDINT     | 66-80    | 16-50    | ST := round(ST) |

### Discussion

FRNDINT rounds the stack top ST to an integer according to the setting of the RC field of the floating-point coprocessor control word. The result replaces the input value on the floating-point stack top.

For example, assume that ST contains the real number 155.625. FRNDINT changes the value to 155 if the RC field of the control word is set to round down (01) or chop (11). FRNDINT changes the value to 156 if the RC field is set to round up (10) or round to nearest with even preferred (00). See Figure 7-5 for control word layout.

### Exceptions

Invalid, precision

**FRSTOR** Restore Floating-point Coprocessor Machine State

| Opcode | Instruction             | Clocks   |          | Description                                    |
|--------|-------------------------|----------|----------|------------------------------------------------|
|        |                         | i387 NPX | i287 NPX |                                                |
| DD /4  | FRSTOR <i>m94/108by</i> | 308      | 205-215  | Machine_state := <i>m94by</i> or <i>m108by</i> |

**Discussion**

FRSTOR restores the entire state of the floating-point coprocessor from the 94- or 108-byte memory location specified by the operand.

This information should have been written by a previous FSAVE instruction and not altered by any subsequent instruction. See Figure 7-10 (with the FSAVE instruction) for illustrations of the floating-point coprocessor machine state memory layout. See Figures 7-2 through 7-8 for detailed illustrations of the floating-point coprocessor environments loaded by FRSTOR.

The floating-point coprocessor resets to its new state at the conclusion of FRSTOR. (F)WAIT is not required after FRSTOR. If the exception and mask bits in the memory image so indicate, the floating-point coprocessor generates an exception when the next (F)WAIT or exception-checking numeric instruction occurs.

**Exceptions**

None, except for unmasking an existing exception

## FSAVE/FNSAVE Save Floating-point Coprocessor Machine State

| Opcode   | Instruction             | Clocks               |                      | Description                                                                                           |
|----------|-------------------------|----------------------|----------------------|-------------------------------------------------------------------------------------------------------|
|          |                         | i387 NPX             | i287 NPX             |                                                                                                       |
| 9B DD /6 | FSAVE <i>m94/108by</i>  | 375-376 <sup>†</sup> | 205-215 <sup>†</sup> | <i>m94/108by</i> : =<br>machine_state after<br>check for pending<br>unmasked floating-point<br>errors |
| DD /6    | FNSAVE <i>m94/108by</i> | 375-376              | 205-215              | <i>m94/108by</i> : =<br>machine_state without<br>check for floating-point<br>errors                   |

<sup>†</sup> Add at least 6 clocks for automatic FWAIT.

### Discussion

FSAVE writes the full floating-point coprocessor state (environment plus stack) to the 94- or 108-byte memory location specified by the operand. The USE attribute of the current code segment determines the size of the operand:

- The 94-byte operand applies to a USE16 segment.
- The 108-byte operand applies to a USE32 segment.

FSAVE includes an assembler-generated (F)WAIT instruction. FSAVE/FNSAVE delays its execution until all floating-point coprocessor activity completes normally. The saved image reflects the machine state following the completion of any running instruction.

For the Intel387 coprocessor, values stored in the tag word are determined during the execution of `FSAVE/FNSAVE`. If the tag in the status register indicates that the corresponding register is nonempty, the Intel387 coprocessor examines the data in the register and stores the appropriate tag in memory.

Following the save, the floating-point coprocessor is automatically reinitialized (an implicit `FNINIT` is executed). If a program is to read from the 94- or 108-byte location following `FSAVE`, it must issue an `FWAIT` instruction to ensure that the storage is complete.

Figure 7-10 shows the 94- or 108-byte layout of the floating-point coprocessor machine state. The layout is composed of the 14- or 28-byte environment and the eight extended precision stack elements. The tags stored always reflect the actual contents of the registers.

Typically, `FSAVE` will be coded to save this image on the processor stack. See Figures 7-2 through 7-8 for details of the environment layout.

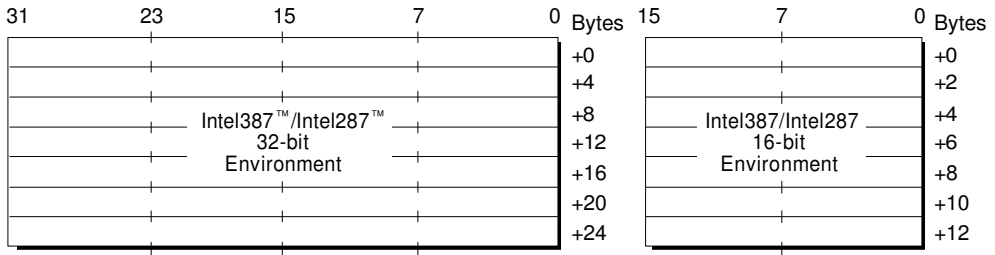

Floating Point Stack

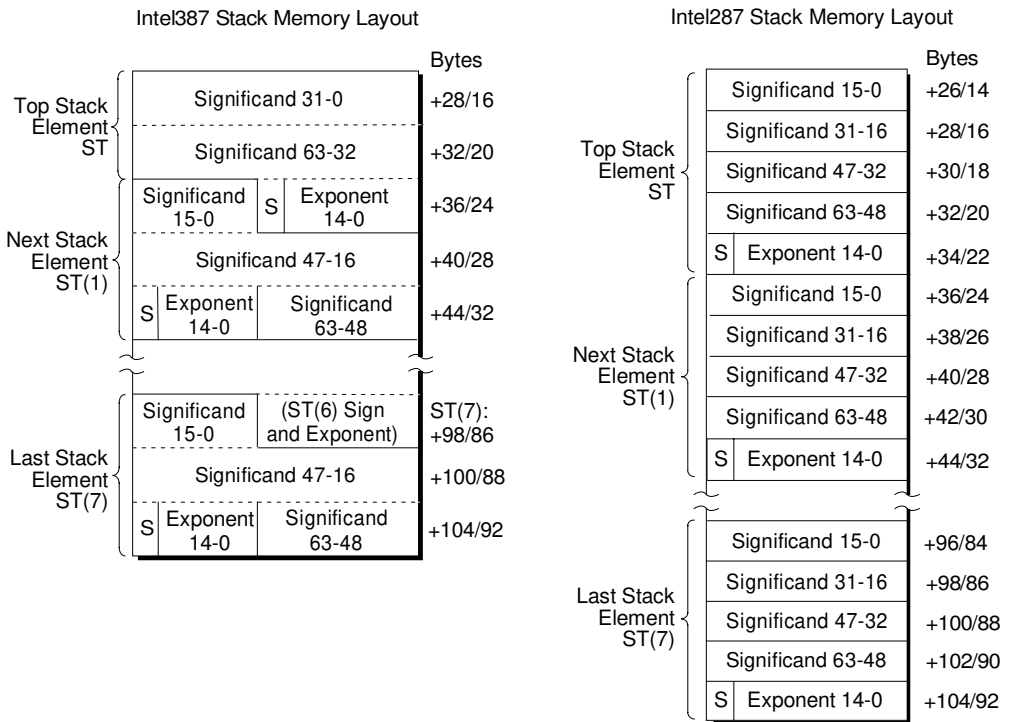

W-3435

**Figure 7-10. Floating-point Coprocessor Machine State Layout after FSAVE**

## **FSAVE/FNSAVE**

---

Some uses of `FSAVE` are:

- An operating system needs to perform a context switch (suspend the task that has been running and give control to a new task)
- An exception handler needs to use the floating-point coprocessor
- An application task wants to pass a clean floating-point coprocessor to a subroutine

### **Exceptions**

None

## FSCALE Scale Exponent of Real

| Opcode | Instruction | Clocks   |          | Description                 |
|--------|-------------|----------|----------|-----------------------------|
|        |             | i387 NPX | i287 NPX |                             |
| D9 FD  | FSCALE      | 67-86    | 32-38    | ST := ST*2 <sup>ST(1)</sup> |

### Discussion

FSCALE adds the integer part of ST(1) to the exponent of the number in ST. FSCALE does rapid multiplication or division by integral powers of 2.

For the Intel387 coprocessor, there is no limit on the range of the scale term in ST(1). If the ST(1) value is not integral, FSCALE chops the value toward zero. If the resulting ST(1) integer is zero, FSCALE does not change the number in ST.

For the Intel287 coprocessor, the scale factor in ST(1) must be in the range  $-2^{15} \leq \text{ST}(1) < +2^{15}$ . FSCALE produces definable results for nonintegral values of ST(1) only if  $|\text{ST}(1)| > 1$ . In that case, the integer produced by chopping ST(1) toward 0 is used. If the input is invalid, the result is undefined and no exception is generated. To ensure correct operation, load the scale factor from a word integer.

### Exceptions

#### Intel387 NPX

Invalid, denormalized, overflow, underflow, precision (on masked underflow/overflow)

#### Intel287 NPX

Invalid, overflow, underflow

## FSETPM Set Protected Mode

| Opcode   | Instruction | Clocks   |                  | Description                     |
|----------|-------------|----------|------------------|---------------------------------|
|          |             | i387 NPX | i287 NPX         |                                 |
| 9B DB E4 | FSETPM      | -----    | 2-8 <sup>†</sup> | Set protected mode for i287 NPX |
| 9B DB E4 | FSETPM      | 12       | -----            | NOP in i387 NPX                 |

<sup>†</sup> Add at least 6 clocks for automatic FWAIT

### Discussion

FSETPM puts the Intel287 coprocessor into protected mode. This instruction should be executed in the power-up initialization routine of the processor, when the processor is placed into protected mode. Once FSETPM is executed, the Intel287 coprocessor remains in protected mode until the next hardware RESET#, even after execution of FINIT, FSAVE, or FRSTOR.

For the Intel387 coprocessor, FSETPM is handled as a NOP (no operation). The processor handles all addressing and exception pointer information, whether in protected mode or not.

### Exceptions

None

**FSIN** Compute  $Y = \sin(X)$ 

| Opcode | Instruction | Clocks               |          | Description   |
|--------|-------------|----------------------|----------|---------------|
|        |             | i387 NPX             | i287 NPX |               |
| D9 FE  | FSIN        | 122-771 <sup>†</sup> | -----    | ST := sin(ST) |

<sup>†</sup> Add up to 76 clocks when  $|ST| \geq \pi/4$ .

**Discussion**

When complete, `FSIN` replaces the contents of `ST` with  $\sin(ST)$ . `ST` must be an angle expressed in radians. It must lie in the range  $|ST| < (\pi/4 * 2^{63})$ .

If `ST` is in range, `C2` of the Intel387 coprocessor status word is cleared and the result of the operation is put in `ST`. Otherwise, `C2` is set to 1 (function incomplete) and the operand value of `ST` remains intact. (See Figure 7-4 for the status word format.)

It is the programmer's responsibility to reduce the operand to an absolute value less than  $(\pi/4 * 2^{63})$ . Use `FPREM1` or `FPREM` if it is necessary to bring `ST` into range. For `ST` in the range  $\pi/4 < |ST| < (\pi/4 * 2^{63})$ , `FSIN` automatically reduces `ST` to a value less than  $\pi/4$  using an internally stored  $\pi/4$  divisor with 67 significant bits.

`FSIN` is a Intel387 coprocessor instruction; it is not available for a Intel287 coprocessor.

**Exceptions**

Invalid, denormalized, underflow, precision

## FSINCOS Compute $Y = \sin(X)$ and $Y = \cos(X)$

| Opcode | Instruction | Clocks               |          | Description                           |
|--------|-------------|----------------------|----------|---------------------------------------|
|        |             | i387 NPX             | i287 NPX |                                       |
| D9 FB  | FSINCOS     | 194-809 <sup>†</sup> | —        | ST := sin(ST), push,<br>ST := cos(ST) |

<sup>†</sup> Add up to 76 clocks when  $|ST| \geq \pi/4$ .

### Discussion

When complete, `FSINCOS` replaces the contents of ST with  $\cos(ST)$  after putting  $\sin(ST)$  in ST(1). ST must be an angle expressed in radians, and it must lie in the range  $|ST| < (\pi/4 * 2^{63})$ .

If ST is in range, C2 of the Intel387 coprocessor status word is cleared and the results of the operation are produced. Otherwise, C2 is set to 1 (function incomplete) and the operand value of ST remains intact. (See Figure 7-4 for the status word layout.)

It is the programmer's responsibility to reduce the operand to an absolute value less than  $(\pi/4 * 2^{63})$ . Use `FPREM1` or `FPREM` if it is necessary to bring ST into range.

For ST in the range  $\pi/4 < |ST| < (\pi/4 * 2^{63})$ , `FSINCOS` automatically reduces ST to a value less than  $\pi/4$  using an internally stored  $\pi/4$  divisor with 67 significant bits.

`FSINCOS` is a Intel387 coprocessor instruction; it is not available for a Intel287 coprocessor.

### Exceptions

Invalid (stack overflow if ST(7) is nonempty), denormalized, underflow, precision

## FSQRT Square Root

| Opcode | Instruction | Clocks   |          | Description           |
|--------|-------------|----------|----------|-----------------------|
|        |             | i387 NPX | i287 NPX |                       |
| D9 FA  | FSQRT       | 122-129  | 180-186  | ST := square_root(ST) |

### Discussion

FSQRT replaces the contents of the top of the stack with its square root.

The FSQRT of (ST = -0) is defined to be -0. Otherwise, FSQRT of a negative operand is invalid.

For the Intel387 coprocessor with the denormal exception masked, a denormal operand produces a correct square root.

For the Intel287 coprocessor, a denormal or unnormal operand generates an invalid exception.

### Exceptions

#### Intel387 NPX

Invalid, denormalized, underflow for unmasked denormal, precision

#### Intel287 NPX

Invalid, denormalized, precision

## FST/FSTP Store Real/Store Real and Pop

| Opcode  | Instruction         | Clocks   |          | Description               |
|---------|---------------------|----------|----------|---------------------------|
|         |                     | i387 NPX | i287 NPX |                           |
| DD D0+i | FST ST( <i>i</i> )  | 11       | 15-22    | ST( <i>i</i> ) := ST      |
| D9 /2   | FST <i>m32r</i>     | 44       | 84-90    | <i>m32r</i> := ST         |
| DD /2   | FST <i>m64r</i>     | 45       | 96-104   | <i>m64r</i> := ST         |
| DD D8+i | FSTP ST( <i>i</i> ) | 12       | 17-24    | ST( <i>i</i> ) := ST, pop |
| D9 /3   | FSTP <i>m32r</i>    | 44       | 86-92    | <i>m32r</i> := ST, pop    |
| DD /3   | FSTP <i>m64r</i>    | 45       | 98-106   | <i>m64r</i> := ST, pop    |
| DB /7   | FSTP <i>m80r</i>    | 53       | 52-58    | <i>m80r</i> := ST, pop    |

### Discussion

FST/FSTP copies the stack top ST to the destination indicated by the operand. FSTP pops the stack after copying ST.

The destination can be a stack element or a single or double precision real memory operand. If the destination is a single or double precision real, FST/FSTP rounds ST to the width of the destination according to the RC field of the floating-point coprocessor control word. FST/FSTP also converts the exponent to the width and bias of the destination format.

FSTP stores extended precision real (DT) memory variables while FST does not. Coding FSTP ST(0) is equivalent to popping the stack with no data transfer.

FST/FSTP does not round ST:

- When the Intel387 coprocessor ST contains an unsupported format, FST/FSTP stores the QNaN indefinite if the invalid exception is masked.
- When the Intel387 coprocessor ST contains NaN, FST/FSTP sets the leading fraction bit and truncates the least significant bits of the significand and exponent to fit the destination.
- When ST contains an infinity or a Intel287 coprocessor NaN, FST/FSTP truncates the least significant bits of the stack top's significand and exponent to make the value fit the destination.

See also: *Programmer's Reference* for your coprocessor, for more information about the special values handled by FST/FSTP

### Exceptions

Invalid; overflow, underflow, precision for single or double precision destination

**FSTCW/FNSTCW**

Store Floating-point Coprocessor Control  
Word

| Opcode   | Instruction        | Clocks          |                    | Description                                                                                 |
|----------|--------------------|-----------------|--------------------|---------------------------------------------------------------------------------------------|
|          |                    | i387 NPX        | i287 NPX           |                                                                                             |
| 9B D9 /7 | FSTCW <i>m2by</i>  | 15 <sup>†</sup> | 12-18 <sup>†</sup> | <i>m2by</i> := control_word<br>after check for pending<br>unmasked floating-point<br>errors |
| D9 /7    | FNSTCW <i>m2by</i> | 15              | 12-18              | <i>m2by</i> := control_word<br>without check for<br>floating-point errors                   |

<sup>†</sup> Add at least 6 clocks for automatic FWAIT.

**Discussion**

FSTCW writes the current floating-point coprocessor control word to the two-byte memory location defined by the operand. FSTCW includes an assembler-generated (F)WAIT instruction. FNSTCW can be used in code regions that must not be interrupted by pending unmasked numeric errors. See Figure 7-5 for the control word format.

**Exceptions**

None

## FSTENV/FNSTENV Store Floating-point Coprocessor Environment

| Opcode   | Instruction             | Clocks               |                    | Description                                                                            |
|----------|-------------------------|----------------------|--------------------|----------------------------------------------------------------------------------------|
|          |                         | i387 NPX             | i287 NPX           |                                                                                        |
| 9B D9 /6 | FSTENV <i>m14/28by</i>  | 103-104 <sup>†</sup> | 40-50 <sup>†</sup> | <i>m14/28by</i> : = environment after check for pending unmasked floating-point errors |
| D9 /6    | FNSTENV <i>m14/28by</i> | 103-104              | 40-50              | <i>m14/28by</i> : = environment without check for floating-point errors                |

<sup>†</sup> Add at least 6 clocks for automatic FWAIT.

### Discussion

FSTENV writes the floating-point coprocessor environment to the 14- or 28-byte memory location specified by the operand. The USE attribute of the current code segment determines the operand size:

- The 14-byte operand applies to a USE16 segment.
- The 28-byte operand applies to a USE32 segment.

The environment consists of the floating-point coprocessor control word, status word, tag word, and the exception pointers. See Figures 7-2 through 7-8 for detailed illustrations of the environment layouts.

FSTENV includes an assembler-generated WAIT instruction. FNSTENV does not, but the data saved reflects the state of the floating-point coprocessor after any previously decoded instruction has been executed.

FNSTENV is often used by exception handlers because it provides access to exception pointers that identify the offending instruction and operand. FNSTENV typically saves the environment on the processor stack. After saving the environment, FNSTENV sets all exception masks in the floating-point coprocessor control word. This prevents numeric errors from interrupting the exception handler.

### Exceptions

None

## FSTSW/FNSTSW Store Floating-point Coprocessor Status Word

| Opcode   | Instruction        | Clocks          |                    | Description                                                                          |
|----------|--------------------|-----------------|--------------------|--------------------------------------------------------------------------------------|
|          |                    | i387 NPX        | i287 NPX           |                                                                                      |
| 9B DF F0 | FSTSW AX           | 13 <sup>†</sup> | 10-16 <sup>†</sup> | AX := status_word<br>after check for pending unmasked floating-point errors          |
| 9B DD /7 | FSTSW <i>m2by</i>  | 15 <sup>†</sup> | 12-18 <sup>†</sup> | <i>m2by</i> := status_word<br>after check for pending unmasked floating-point errors |
| DF F0    | FNSTSW AX          | 13              | 10-16              | AX := status_word<br>without check for floating-point errors                         |
| DD /7    | FNSTSW <i>m2by</i> | 15              | 12-18              | <i>m2by</i> := status_word<br>without check for floating-point errors                |

<sup>†</sup> Add at least 6 clocks for automatic FWAIT.

### Discussion

FSTSW writes the current value of the floating-point coprocessor status word to the operand. The destination is either the AX register or a two-byte memory operand.

FSTSW includes an assembler-generated (F)WAIT instruction. FNSTSW reads the status word without checking for pending unmasked numeric errors, but it delays execution until any running numeric instruction is finished.

The primary use of FSTSW/FNSTSW is to do conditional branching following a comparison, FPREM/FPREM1, or FXAM instruction.

When FNSTSW AX is executed, the processor AX register is updated with the floating-point coprocessor status word before the processor executes any further instructions.

### Exceptions

None

**FSUB/FSUBP/FSUBR/FSUBRP** Subtract Real

| Opcode  | Instruction       | Clocks   |          | Description                 |
|---------|-------------------|----------|----------|-----------------------------|
|         |                   | i387 NPX | i287 NPX |                             |
| DE E9   | FSUB              | 26-34    | 75-105   | ST(1) := ST(1) - ST,<br>pop |
| DC E8+i | FSUB ST(i),ST     | 26-34    | 70-100   | ST(i) := ST(i) - ST         |
| D8 E0+i | FSUB ST,ST(i)     | 29-37    | 70-100   | ST := ST - ST(i)            |
| D8 /4   | FSUB <i>m32r</i>  | 24-32    | 90-120   | ST := ST - <i>m32r</i>      |
| DC /4   | FSUB <i>m64r</i>  | 28-36    | 95-125   | ST := ST - <i>m64r</i>      |
| DE E8+i | FSUBP ST(i),ST    | 26-34    | 75-105   | ST(i) := ST(i) - ST,<br>pop |
| DE E1   | FSUBR             | 26-34    | 75-105   | ST(1) := ST - ST(1),<br>pop |
| DC E0+i | FSUBR ST(i),ST    | 26-34    | 70-100   | ST(i) := ST - ST(i)         |
| D8 E8+i | FSUBR ST,ST(i)    | 29-37    | 70-100   | ST := ST(i) - ST            |
| D8 /5   | FSUBR <i>m32r</i> | 25-33    | 90-120   | ST := <i>m32r</i> - ST      |
| DC /5   | FSUBR <i>m64r</i> | 29-37    | 95-125   | ST := <i>m64r</i> - ST      |
| DE E0+i | FSUBRP ST(i),ST   | 26-34    | 75-105   | ST(i) := ST - ST(i),<br>pop |

## Discussion

FSUB/FSUBP/FSUBR/FSUBRP subtract floating-point numbers. These instructions always use ST as one of the operands. The other operand may be another stack element or a single or double precision real memory operand.

The two-operand forms of the FSUB/FSUBP instructions subtract the second operand (subtrahend) from the first operand, replacing the first operand (minuend) with the result. The one-operand forms subtract the operand from the stack top, replacing the stack top with the result.

FSUBR/FSUBRP reverse the operands and the destination of the result. The two-operand forms of these instructions subtract the first operand from the second, replacing the first operand (subtrahend) with the result.

The FSUBP/FSUBRP instructions return a result to ST(i). The FSUB/FSUBR instructions with no operands return a result to ST(1). These instructions pop the top element (old ST(0)) from the stack when the operation is complete.

## Exceptions

Invalid, denormalized, overflow, underflow, precision

## FTST Test Real (Compare to Zero)

| Opcode | Instruction | Clocks   |          | Description        |
|--------|-------------|----------|----------|--------------------|
|        |             | i387 NPX | i287 NPX |                    |
| D9 E4  | FTST        | 28       | 38-48    | Compare ST to +0.0 |

### Discussion

FTST compares the stack top ST with the value +0.0 and sets the flags C3, C2, and C0 of the floating-point coprocessor status word with the resulting information. There are four possible results to the comparison of two real numbers. Three are greater than, equals, and less than. The fourth, unordered, occurs when one of the compared quantities is a NaN, a Intel387 coprocessor unsupported format, or a Intel287 coprocessor projective infinity. The flags C3, C2, and C0 (bits 14, 10, and 8, respectively of the floating-point coprocessor status word) indicate the result of an FTST comparison, as shown in Table 7-15.

**Table 7-15. Condition Code after FTST**

| Order     | (ZF)<br>C3 | (PF)<br>C2 | (CF)<br>C0 | Processor<br>Conditional Branch |
|-----------|------------|------------|------------|---------------------------------|
| ST >0.0   | 0          | 0          | 0          | JA                              |
| ST <0.0   | 0          | 0          | 1          | JB                              |
| ST = 0.0  | 1          | 0          | 0          | JE                              |
| Unordered | 1          | 1          | 1          | JP                              |

To test these bits, load them into the processor flags register by following FTST with the following instruction sequence:

```

FSTSW AX    ; store status word in AX
SAHF       ; bits are now stored in zero,
           ; parity, and carry flags
JPE UNORDR ; JUMP if the result was unordered
    
```

Conditional jumps can now be made, using the below (JB), above (JA), and equal (JE) mnemonics.

### Exceptions

Invalid, denormalized

**FUCOM/FUCOMP/FUCOMPP**    Unordered Comparison of  
Real Numbers

| Opcode          | Instruction           | Clocks   |          | Description                            |
|-----------------|-----------------------|----------|----------|----------------------------------------|
|                 |                       | i387 NPX | i287 NPX |                                        |
| DD E1           | FUCOM                 | 24       | -----    | Compare ST with ST(1)                  |
| DD E0+ <i>i</i> | FUCOM ST( <i>i</i> )  | 24       | -----    | Compare ST with ST( <i>i</i> )         |
| DD E9           | FUCOMP                | 26       | -----    | Compare ST with<br>ST(1), pop          |
| DD E8+ <i>i</i> | FUCOMP ST( <i>i</i> ) | 26       | -----    | Compare ST with ST( <i>i</i> ),<br>pop |
| DA E9           | FUCOMPP               | 26       | -----    | Compare ST with<br>ST(1), pop twice    |

**Discussion**

FUCOM/FUCOMP/FUCOMPP compare real numbers on the stack. After making the comparison, FUCOMP pops the top element from the stack. After comparing the top two elements, FUCOMPP pops both of them.

FUCOM, FUCOMP, and FUCOMPP are Intel387 coprocessor instructions. These instructions conform to the IEEE 754 standard for the comparison of real numbers, differing from FCOM/FCOMP/FCOMPP as follows:

- FUCOM/FUCOMP/FUCOMPP do not cause an invalid operation unless an operand is a signaling NaN or is empty.
- FUCOM/FUCOMP/FUCOMPP compare stack operands only.  
FCOM/FCOMP/FCOMPP also compare memory operands to the stack top.

There are four possible results to the comparison of two real numbers as shown in Table 7-16. Three are greater than, less than, and equals. The fourth, unordered, (not comparable) occurs when one of the operands is a NaN or an unsupported Intel387 coprocessor format.

**Table 7-16. Condition Code after FUCOM(P/PP)**

| Order        | (ZF)<br>C3 | (PF)<br>C2 | (CF)<br>C0 | Processor<br>Conditional Branch |
|--------------|------------|------------|------------|---------------------------------|
| ST >Operand  | 0          | 0          | 0          | JA                              |
| ST <Operand  | 0          | 0          | 1          | JB                              |
| ST = Operand | 1          | 0          | 0          | JE                              |
| Unordered    | 1          | 1          | 1          | JP                              |

To test these bits, load them into the processor flags register by following FUCOM with the following instruction sequence:

```

FSTSW AX    ; store status word in AX
SAHF       ; bits are now stored in zero,
           ; parity, and carry flags
JPE UNORDR ; JUMP if the result was unordered
    
```

Conditional jumps can now be made, using the below (JB), above (JA), and equal (JE) mnemonics. FUCOM/FUCOMP/FUCOMPP ignores the sign of zero: -0.0 = +0.0.

## Exceptions

Invalid, denormalized

## **FWAIT** Wait for Floating-point Operation Complete

| <b>Opcode</b> | <b>Instruction</b> | <b>Clocks</b> | <b>Description</b> |
|---------------|--------------------|---------------|--------------------|
| 9B            | FWAIT              | min. 6        | Alternate of WAIT  |

### **Discussion**

FWAIT is an alternate mnemonic for the processor WAIT instruction.

(F)WAIT allows a check to be made for pending unmasked floating-point errors before the next floating-point coprocessor instruction modifies a variable used in the preceding instruction. This transfers control to exception handlers that deal with such exceptions before the next floating-point coprocessor instruction uses invalid results as an operand.

FWAIT also synchronizes the processor with the Intel287 coprocessor. FWAIT suspends processor execution until the Intel287 coprocessor completes its current instruction. Follow FIST with an FWAIT instruction to be sure that the value has been stored before attempting to examine it.

### **Exceptions**

None; the processor raises the following exceptions: #NM if the task-switched flag is set in the machine status word (lower 16 bits of CR0); #MF if the ERROR# pin is asserted

## FXAM Examine Floating-point Stack Top

| Opcode | Instruction | Clocks   |          | Description                                              |
|--------|-------------|----------|----------|----------------------------------------------------------|
|        |             | i387 NPX | i287 NPX |                                                          |
| D9 E5  | FXAM        | 30-38    | 12-23    | Status_word<br>condition_bits :=<br>classification of ST |

### Discussion

FXAM provides information about the classification of the floating-point coprocessor stack top value. The results are reported by the condition codes C3-C0 of the floating-point coprocessor status word, as shown in Table 7-17.

**Table 7-17. Condition Code after FXAM**

| C3 | Condition Code |    |    | Interpretation of Floating-point Coprocessors ST value |
|----|----------------|----|----|--------------------------------------------------------|
|    | C2             | C1 | C0 |                                                        |
| 0  | 0              | 0  | 0  | i387 NPX: Unsupported;<br>i287 NPX: +Unnormal          |
| 0  | 0              | 0  | 1  | +NaN                                                   |
| 0  | 0              | 1  | 0  | i387 NPX: Unsupported;<br>i287 NPX: -Unnormal          |
| 0  | 0              | 1  | 1  | -NaN                                                   |
| 0  | 1              | 0  | 0  | +Normal                                                |
| 0  | 1              | 0  | 1  | +∞                                                     |
| 0  | 1              | 1  | 0  | -Normal                                                |
| 0  | 1              | 1  | 1  | -∞                                                     |
| 1  | 0              | 0  | 0  | +Zero                                                  |
| 1  | 0              | 0  | 1  | Empty                                                  |
| 1  | 0              | 1  | 0  | -Zero                                                  |
| 1  | 0              | 1  | 1  | Empty                                                  |
| 1  | 1              | 0  | 0  | +Denormal                                              |
| 1  | 1              | 0  | 1  | i287 NPX: Empty                                        |
| 1  | 1              | 1  | 0  | -Denormal                                              |
| 1  | 1              | 1  | 1  | i287 NPX: Empty                                        |

Although four different encodings can be returned for an empty register, bits C3 and C0 are always 1 for empty. Ignore bits C2 and C1 when testing for empty.

### Exceptions

None

## FXCH Exchange Real Numbers in Stack

| Opcode  | Instruction         | Clocks   |          | Description                    |
|---------|---------------------|----------|----------|--------------------------------|
|         |                     | i387 NPX | i287 NPX |                                |
| D9 C9   | FXCH                | 18       | 10-15    | Exchange ST and ST(1)          |
| D9 C8+i | FXCH ST( <i>i</i> ) | 18       | 10-15    | Exchange ST and ST( <i>i</i> ) |

### Discussion

FXCH swaps the contents of the stack top ST with the stack element given as the operand. If a stack element is not specified explicitly, ST(1) is used.

Many floating-point coprocessor instructions operate only on the stack top. FXCH provides an easy way to use these instructions on lower stack elements. For example, the following sequence takes the square root of the third element from the top (assuming that ST is nonempty):

```
FXCH ST(3)
FSQRT
FXCH ST(3)
```

### Exceptions

Invalid

## FXTRACT Extract Exponent and Significand of Real

| Opcode | Instruction | Clocks   |          | Description                                                  |
|--------|-------------|----------|----------|--------------------------------------------------------------|
|        |             | i387 NPX | i287 NPX |                                                              |
| D9 F4  | FXTRACT     | 70-76    | 27-55    | Push, ST(1) :=<br>ST_exponent_field,<br>ST := ST_significand |

### Discussion

FXTRACT decomposes the stack top ST into two numbers that represent the actual value of the operand's exponent and significand fields. The exponent replaces the original operand on the stack. Then, FXTRACT pushes the significand onto the stack. ST(7) must be empty to avoid an invalid exception.

After FXTRACT on a valid operand, ST contains the value of the original significand expressed as a real number:

- Its sign is the same as the original operand's.
- Its exponent is zero true (3FFFH biased).
- Its significand is identical to the original operand's.

After FXTRACT on a valid operand, ST(1) contains the original operand's exponent. For example, assume that ST contains a number whose true exponent is +4 (the exponent field contains 4003H). After FXTRACT, ST(1)'s exponent field will contain 4001H (+2 true) and its significand field will contain  $1.0_{10}$  (1.0).

As an example with a negative exponent, suppose ST contains an operand whose true exponent is -7 (the exponent field contains 3FF8H). After FXTRACT, ST(1)'s exponent field will contain C001H (-2 true) and its significand field will contain  $1.1100_{10}$  (1.1100).

## FXTRACT

---

The Intel287 and Intel387 coprocessors `FXTRACTS` handle zero, denormal, or infinity operands differently:

- When the operand is a zero, Intel387 coprocessor `FXTRACT` leaves 0.0 in ST with the same sign as the operand and leaves  $-\infty$  in ST(1); the Intel387 coprocessor also raises the zerodivide exception. When the operand is a denormal and the denormal exception is masked, Intel387 coprocessor `FXTRACT` leaves a normalized significand in ST and the exponent of the normalized operand in ST(1). When the operand is an infinity, Intel387 coprocessor `FXTRACT` leaves the original operand in ST and  $+\infty$  in ST(1), and the Intel387 coprocessor does not raise an exception.
- When the operand is a zero, Intel287 coprocessor `FXTRACT` leaves 0's in both ST and ST(1) with the same sign as the original operand. When the operand is a denormal, Intel287 coprocessor `FXTRACT` leaves an unnormalized significand in ST and the operand's exponent in ST(1). When the operand is an infinity, Intel287 coprocessor `FXTRACT` raises the invalid exception.

### Exceptions

#### Intel387 NPX

Invalid, denormal, zerodivide

#### Intel287 NPX

Invalid

**FYL2X** Compute  $Y * \log_2 X$ 

| Opcode | Instruction | Clocks   |          | Description                                |
|--------|-------------|----------|----------|--------------------------------------------|
|        |             | i387 NPX | i287 NPX |                                            |
| D9 F1  | FYL2X       | 120-538  | 900-1100 | ST(1) := ST(1) * $\log_2$ (ST), pop old ST |

**Discussion**

FYL2X calculates  $ST(1) * \log_2(ST)$ . FYL2X stores the result in ST(1) and then pops the stack, leaving the answer in ST.

The ST(1) operand to FYL2X must be in the range  $-\infty < ST(1) < +\infty$ , and:

- For the Intel387 coprocessor FYL2X, the ST operand must be in the range  $0 \leq ST < +\infty$ .
- For the Intel287 coprocessor FYL2X, the ST operand must be in the range  $0 < ST < +\infty$ .

FYL2X optimizes the calculation of log to any base other than 2 by providing the multiplication that is always required:

- $\log_b X = \log_b 2 * \log_2 X$

**Exceptions****Intel387 NPX**

Invalid, denormalized, zerodivide, overflow, underflow, precision

**Intel287 NPX**

Overflow, underflow, precision

## FYL2XP1 Compute $Y * \log_2(X + 1)$

| Opcode | Instruction | Clocks   |          | Description                                    |
|--------|-------------|----------|----------|------------------------------------------------|
|        |             | i387 NPX | i287 NPX |                                                |
| D9 F9  | FYL2XP1     | 257-547  | 700-1000 | ST(1) := ST(1) * $\log_2(ST + 1)$ , pop old ST |

### Discussion

FYL2XP1 calculates  $ST(1) * \log_2(ST + 1.0)$ . FYL2XP1 stores the result in ST(1) and then pops the stack, leaving the answer in ST.

FYL2XP1 provides improved accuracy over FYL2X when computing the logarithm of a number very close to 1.

The ST(1) operand to FYL2XP1 must be in the range  $-\infty < ST(1) < +\infty$ , and:

- For Intel387 coprocessor FYL2XP1, the ST operand must be in the range  $-(1-\sqrt{2}/2) < ST < +(1-\sqrt{2}/2)$ . If either operand is out of range, the result is undefined.
- For Intel287 coprocessor FYL2XP1, the ST operand must be in the range  $0.0 \leq |ST| < +(1-\sqrt{2}/2)$ . If either operand is out of range, FYL2XP1 results are undefined and no exception is generated.

It is the programmer's responsibility to check that these operands are in range.

### Exceptions

#### Intel387 NPX

Invalid, denormalized, underflow, precision

#### Intel287 NPX

Underflow, precision



This chapter describes assembler textmacros. The chapter has three major sections.

- Overview explains what textmacros are and describes the basics of using them.
- Predefined Macro Reference describes the predefined macros in detail.
- Scanning Modes, Delimiters, and Macro Expansions contains more detailed information about these topics than the Overview section.

## Overview

Textmacros are optional, programmer-defined functions that have two major uses in assembler programs:

- As convenient abbreviations for a sequence of assembler statements that will be reused
- As a way to assemble sections of code conditionally

For example, the following source module fragment defines two macros (`PROLOG` and `EPILOG`) for reuse with three procedures:

```
        NAME TEXT_SUB
        PUBLIC PROC1,PROC2,PROC3

:      :
%*DEFINE (PROLOG) (
        PUSH EBP
        MOV EBP, ESP
        )
%*DEFINE (EPILOG) (
        POP EBP
        RET 8
        )

:      :
```

Each macro definition specifies a macro name followed by a macro body containing assembler instruction statements. `PROC1`, `PROC2`, and `PROC3` perform similar operations with data on the stack. The source module's code segment contains macro calls to `PROLOG` and `EPILOG` inside each of these procedures.

The following fragment shows how the PROLOG and EPILOG calls appear within

PROC1:

```
CODE32    SEGMENT ER PUBLIC
:         :
PROC1     PROC
          %PROLOG
          MOV EAX, [EBP+8]
          ADD EAX, [EBP+12]      ; in PROC1 only
          %EPILOG
PROC1     ENDP
:         :
```

PROC2 and PROC3 are almost identical to PROC1, except for the commented ADD statement. PROC2 uses SUB and PROC3 uses IMUL on the same operands as PROC1.

In the listing for this source module, the PROC1 fragment appears as:

```
CODE32    SEGMENT ER PUBLIC
:         :
PROC1     PROC
          PUSH EBP              ; instead of
          MOV EBP,ESP          ; PROLOG call
          MOV EAX, [EBP+8]
          ADD EAX, [EBP+12]
          POP EBP              ; instead of
          RET 8                ; EPILOG call
PROC1     ENDP
:         :
```

The macro body defined with PROLOG replaces each %PROLOG in the source file versions of PROC1, PROC2, and PROC3. The macro body defined with EPILOG replaces each %EPILOG.

See also: *Controlling the macro processor and controlling the listing of macros, ASM386 Macro Assembler Operating Instructions*

## Macro Processing

The macro processor preprocesses assembler source text before it is assembled. The macro processor scans the source text for macro calls, which are signaled by a specific metacharacter (`%`, by default). When it encounters a macro call, the macro processor:

1. Expands the macro to its return value, which is usually text but is sometimes the null string
2. Inserts the expanded result into the source file that will be input to the assembler
3. Updates information in the macro processor symbol table and continues scanning the source file for another macro call

The macro processor ignores assembler directive, instruction, and codemacro statements in the source file, passing them on as a sequence of characters to the assembler. Until it encounters the metacharacter, the macro processor scans the file as a stream of characters with no semantic content. The macro processor cannot access the assembler's symbol table because it expands macros prior to assembly.

After macro processing, the assembler processes the source file's assembly language statements, including every statement that has been inserted as the result of a macro call.

## Macro Calls and Call Patterns

The term macro call denotes an invocation of a macro identifier recognized by the macro processor. Such an identifier may be:

- An assembler predefined macro
- A previously defined macro

Each kind of macro call begins with the metacharacter, followed by the call pattern of the macro. A call pattern is the macro name, followed by a delimited list of arguments if the call pattern requires arguments.

Each predefined macro has its own call pattern. Some require a parenthesized expression, macro name, or string argument; some require two or more arguments, enclosed in parentheses and separated by commas. For example, the `SUBSTR` macro's call pattern is:

```
%SUBSTR(balanced-text, expr1, expr2)
```

A call to `SUBSTR` must specify three arguments enclosed by parentheses and separated by two commas, such as:

```
%SUBSTR (ABCDEFG, 3, 4)
```

The first argument is a string of balanced text, the second is an index to the initial character of the substring, and the third specifies the length of the substring. The result of this macro call is `CDEF`.

See also:   Macro arguments, in this chapter

Each programmer-defined macro also has its own call pattern. The call pattern is specified in the macro's definition. Every macro definition must specify a macro name and a macro body that is expanded when the macro is called. A macro definition may include formal parameters that must be replaced by arguments each time the macro is called; it may also include `LOCAL` symbols that will be expanded into assembly time symbols.

A macro definition may contain calls to other macros nested within its macro body. The macro processor expands a macro body according to its definition every time the macro is called. The result of a macro call is the fully expanded macro body, including the fully expanded results of any nested macro calls.

Each macro call must match its defined call pattern exactly. There must be an argument to match each formal parameter. Argument delimiters must match those required by the predefined macro or those specified in the macro's definition.

## Macro Processor Scanning Modes and Macro Expansions

The macro processor has two scanning modes for processing macros:

1. Normal scanning mode -- expands macro calls, including nested macro calls
2. Literal scanning mode -- does not expand calls nested in the macro body, but updates the macro processor symbol table

By default, the macro processor scans calls to predefined and programmer-defined macros in normal scanning mode: it replaces the macro call with an expanded result and passes the expanded text on to the assembler.

In normal scanning mode:

- For a predefined macro, the macro processor returns a null string for the macro name and an expanded text result for the call.

See also: Predefined macros, in this chapter

- For a programmer-defined macro, the macro processor returns a null string for the macro name and the expanded text result of the processed macro body. If the definition contains nested macro calls, they are fully expanded when their containing macro is called.

A macro definition is a result of a call to the predefined macro `%*DEFINE`. The asterisk (\*) following the default metacharacter tells the macro processor to use literal scanning mode to process the macro definition. In literal scanning mode:

- The macro processor does not attempt to expand formal parameters or `LOCAL` symbols referenced in the macro body as macro calls.

As a side effect of a literal mode call to `%*DEFINE`, the newly defined macro call pattern (name, formal parameters, and delimiters) enters the macro processor's symbol table, together with the definition's `LOCAL` symbols, if any. The macro processor can recognize a subsequent call to the new macro and expand it fully in normal scanning mode.

See also: Algorithm for evaluating macro calls, in this chapter

## Predefined Macros

The assembler predefined macros are used to create and manipulate macros. Table 8-1 summarizes these macros by usage categories.

**Table 8-1. Predefined Macros**

| <b>Name</b>                                                  | <b>Used For:</b>                                                                                                                                  |
|--------------------------------------------------------------|---------------------------------------------------------------------------------------------------------------------------------------------------|
| <b>Creating New Macros and Controlling Expansion</b>         |                                                                                                                                                   |
| DEFINE                                                       | Defines a macro identifier as callable and a macro body as the result of a call; a formal parameter list and/or a LOCAL list are optional         |
| Bracket                                                      | Tells the macro processor to evaluate a parenthesized string in literal scanning mode                                                             |
| Escape                                                       | Tells the macro processor to evaluate a specified number of characters (n = 1..9) in literal scanning mode                                        |
| Comment                                                      | Puts a comment into a macro definition; always evaluates to the null string when scanned                                                          |
| METACHAR                                                     | Redefines the metacharacter for subsequent macro calls                                                                                            |
| <b>Evaluating Floating-point Expressions</b>                 |                                                                                                                                                   |
| EVAL                                                         | Returns a string of hexadecimal digits representing an expression's value                                                                         |
| SET                                                          | Assigns a numeric value to an identifier and stores the identifier in the macro processor symbol table                                            |
| <b>Expanding a Macro Conditionally and/or More than Once</b> |                                                                                                                                                   |
| IF                                                           | Expands text if specified expression is true or expands optional ELSE clause if specified expression is false; otherwise, returns the null string |
| WHILE                                                        | Expands text repeatedly as long as expression is true                                                                                             |
| REPEAT                                                       | Expands text a specified number of times                                                                                                          |
| EXIT                                                         | Terminates expansion of the most recently called WHILE, REPEAT, or programmer-defined macro                                                       |
| <b>Comparing Strings (true = -01H, false = 00H)</b>          |                                                                                                                                                   |
| EQS                                                          | Returns -01H for equal strings                                                                                                                    |
| NES                                                          | Returns -01H for unequal strings                                                                                                                  |
| LTS                                                          | Returns -01H if left string less than right string                                                                                                |
| GTS                                                          | Returns -01H if left string greater than right string                                                                                             |
| LES                                                          | Returns -01H if left string less than or equal to right string                                                                                    |
| GES                                                          |                                                                                                                                                   |

continued

**Table 8-1. Predefined Macros (continued)**

| <b>Name</b>                    | <b>Used For:</b>                                                                          |
|--------------------------------|-------------------------------------------------------------------------------------------|
| <b>Manipulating Strings</b>    |                                                                                           |
| LEN                            | Returns the length of a string (0..255 characters)                                        |
| SUBSTR                         | Extracts substring from a string                                                          |
| MATCH                          | Splits a string at the specified delimiter and specifies an identifier for each substring |
| <b>Controlling Console I/O</b> |                                                                                           |
| IN                             | Inputs (and echoes) a character string from the console                                   |
| Out                            | Outputs a character string to the console                                                 |
| CI                             | Inputs a character (no echo) from the console                                             |
| CO                             | Outputs a character to the console                                                        |

## Macro Arguments

The following sections describe general rules for macro arguments, including delimiters in call patterns and identifiers in macro definitions.

### Balanced Text

Most arguments to the predefined macros must be balanced text with respect to parentheses. Macro definitions must also be balanced text. A macro definition supplies at least two parenthesized arguments to `DEFINE`: the macro identifier and the macro body. If a macro is defined with formal parameters, the corresponding arguments must be passed as balanced text when the macro is called.

Text is balanced if it conforms to the following rules:

- During the left to right scan, the macro processor's count of unliterated left parentheses must always be greater than or equal to its count of unliterated right parentheses.
- After the scan, the macro processor's count of unliterated left parentheses must equal its count of unliterated right parentheses.

An unbalanced parenthesis may be literalized with the predefined Escape macro to make an argument conform to these rules.

## Delimiters in Call Patterns

The macro processor recognizes two kinds of delimiters used to enclose a list of arguments to a macro call:

1. Literal delimiters such as balanced parentheses
2. Implied blank delimiters

The macro processor recognizes three kinds of delimiters used to separate arguments to a macro call:

1. Literal delimiters such as commas
2. Implied blank delimiters such as spaces
3. ID delimiters

The call patterns for the predefined macros require unliteralized left and right parentheses as enclosing delimiters. Some require the comma as a separating delimiter. The `DEFINE` macro requires the following arguments enclosed in parentheses: the macro name and the macro body. Such a macro definition has no formal parameters, and its call pattern consists of the metacharacter followed immediately by the macro name.

If the macro definition has one formal parameter, it may be enclosed by paired parentheses, by any literal delimiter(s), or by logical spaces. Such a macro's call pattern consists of the metacharacter followed immediately by the macro name followed by an argument that must be enclosed with the same delimiters as the definition has.

The comma may be used to separate elements in a formal parameter list. If the definition of a macro uses commas to separate formal parameters, the corresponding arguments must be separated by commas when the macro is called. The comma is a literal delimiter.

However, the macro processor recognizes other characters as delimiters in defined formal parameter and corresponding argument lists. The macro processor can recognize any single character except the following as a separating literal delimiter:

- The metacharacter
- An unliteralized left or right parenthesis
- The space, tab, carriage return, and linefeed characters
- The at character (@)
- A valid identifier character (A..Z, a..z, 0..9, the underscore, or the question mark)

The space, tab, carriage return, and linefeed characters are logical spaces; they may be used as implied blank delimiters. The at character (@) followed by one or more valid identifier characters is an ID delimiter.

See also: Macro delimiters, in this chapter

## Identifiers

A macro definition specifies the name by which the macro can be called. A macro definition may also specify identifiers for formal parameters and LOCAL symbols. The following summarizes the rules for identifiers in macros:

- An identifier must begin with an alphabetic character (A...Z or a...z).
- The second and subsequent characters may be alphabetic, a question mark (?), an underscore (\_), or decimal digits (0...9).
- Upper- and lower-case characters are interchangeable in identifiers.
- An identifier may not have more than 31 characters.
- An identifier may be terminated by a right parenthesis, a logical space, a null-string Bracket call (%( ) ), or a null-string Escape call (%0).
- Formal parameter identifiers and LOCAL identifiers have scope exclusive to their defining macro. A nested macro cannot reference such symbols.
- A formal parameter or LOCAL identifier has precedence over a nested macro identifier if they are duplicates; the macro processor will not interpret the duplicated symbol as a nested macro call.
- Most predefined macros have reserved identifiers: they may not be used as programmer-defined macro, formal parameter, or LOCAL symbol identifiers. Only the SET macro does not have a reserved identifier; it may be redefined.

A macro cannot be called as a forward reference to its identifier. The definition of a new macro is in effect during macro processing or until the macro identifier is redefined by another call to %\*DEFINE.

## Expressions

Some predefined macros require arguments with numeric values. The macro processor interprets certain text string arguments to EVAL, SET, IF, WHILE, REPEAT, and SUBSTR as numeric expressions.

The macro processor recognizes and evaluates numeric expressions according to the following guidelines:

- Signed integer values may be represented in binary (B suffix), octal (O or Q suffix), decimal (no suffix or D suffix), and hexadecimal (H suffix).
- The range of valid integers is -32768..32767 (decimal).
- The valid expression operators are:

#### **Highest Precedence**

1. ( )
2. HIGH, LOW
3. \*, /, MOD, SHL, SHR
4. +, - (unary and binary)
5. EQ, NE, LE, LT, GE, GT
6. NOT
7. AND
8. OR, XOR

#### **Lowest Precedence**

The `IF` and `WHILE` macros require arguments that are expressions. The macro processor interprets the result of such expressions as true or false based on whether the least significant bit is odd (1 = true) or even (0 = false). The predefined string comparison macros return -01H for true and 00H for false; these macros are valid expression arguments for calls to `IF` and `WHILE`. The macro processor always represents true and false as the character strings -01H and 00H, respectively.

## **Argument Evaluations**

The macro processor uses call-by-immediate-value as it scans arguments to macro calls. For this reason, it evaluates arguments that are nested macro calls whatever the current scanning mode.

For example, suppose `STRNG` is a defined macro with the value `DOGS,CATS` and `MAC1`'s defined call pattern is `MAC1( P1, P2)`. Even if `MAC1` is called in literal mode as follows

```
%*MAC1( %STRNG, mouse)
```

the macro processor will expand the call to `STRNG`. Use the `Bracket` macro on the call to `MAC1` or the `Escape` macro on the call to `STRNG` to postpone the immediate expansion of such an argument.

See also: `Bracket` and `Escape` macros, in this chapter

# Predefined Macro Reference

Table 8-2 summarizes the call pattern syntax for each predefined macro described in the following sections. Except for SET, tokens in uppercase letters are reserved; they may not be used as new macro, formal parameter, or LOCAL symbol identifiers.

**Table 8-2. Predefined Macro Call Patterns**

| <b>Name</b> | <b>Call Pattern Syntax</b>                                                                                                         |
|-------------|------------------------------------------------------------------------------------------------------------------------------------|
| DEFINE      | %[*]DEFINE ( <i>macro-name</i> [ <i>param-list</i> ] ) [LOCAL <i>local-list</i> ] ( <i>macro-body</i> )                            |
| Bracket     | %( <i>balanced-text</i> )                                                                                                          |
| Escape      | %n <i>text-n-chars-long</i>                                                                                                        |
| Comment     | %'text end-line or % 'text'                                                                                                        |
| METACHAR    | %METACHAR ( <i>balanced-text</i> )                                                                                                 |
| EVAL        | %EVAL ( <i>expr</i> )                                                                                                              |
| SET         | %SET ( <i>macro-name</i> , <i>expr</i> )                                                                                           |
| IF          | %IF ( <i>expr</i> ) THEN ( <i>balanced-text1</i> ) [ELSE ( <i>balanced-text2</i> ) ] FI                                            |
| WHILE       | %WHILE ( <i>expr</i> ) ( <i>balanced-text</i> )                                                                                    |
| REPEAT      | %REPEAT ( <i>expr</i> ) ( <i>balanced-text</i> )                                                                                   |
| EXIT        | %EXIT                                                                                                                              |
| EQS         | %EQS ( <i>arg1</i> , <i>arg2</i> )                                                                                                 |
| NES         | %NES ( <i>arg1</i> , <i>arg2</i> )                                                                                                 |
| LTS         | %LTS ( <i>arg1</i> , <i>arg2</i> )                                                                                                 |
| GTS         | %GTS ( <i>arg1</i> , <i>arg2</i> )                                                                                                 |
| LES         | %LES ( <i>arg1</i> , <i>arg2</i> )                                                                                                 |
| GES         | %GES ( <i>arg1</i> , <i>arg2</i> )                                                                                                 |
| LEN         | %LEN ( <i>balanced-text</i> )                                                                                                      |
| SUBSTR      | %SUBSTR ( <i>balanced-text</i> , <i>expr1</i> , <i>expr2</i> )                                                                     |
| MATCH       | %MATCH ( [ <i>ident1</i> ] <i>delim</i> <i>ident2</i> [ <i>delim</i> <i>identN</i> ]...[ <i>delim</i> ] ) ( <i>balanced-text</i> ) |
| IN          | %IN                                                                                                                                |
| OUT         | %OUT ( <i>balanced-text</i> )                                                                                                      |
| CI          | %CI                                                                                                                                |
| CO          | %CO( <i>char</i> )                                                                                                                 |

## DEFINE Macro

### Syntax

```
%[*]DEFINE (macro-name [param-list] ) [LOCAL local-list] (macro-body)
```

Where:

- `%` represents the current metacharacter.
- `*` tells the macro processor to scan the definition in literal mode. The `*` (literal character) may be omitted if the definition has only *macro-name* and *macro-body* arguments; it is required if the definition has a *param-list* and/or *local-list*.

The `%`, optional `*`, and `DEFINE` may not be separated by spaces.

*macro-name*

is a valid identifier; *macro-name* and the optional *param-list* must be enclosed in parentheses.

*param-list*

is an optional list containing one or more valid identifiers separated by literal, implied blank, or ID delimiters. Each identifier in the list must be unique. *Param-list* must be a balanced text string, enclosed by paired parentheses or by literal or implied blank delimiters.

*local-list*

is an optional list containing one or more valid identifiers separated by logical spaces. At least one space is required between `LOCAL` and the initial identifier in a list.

*macro-body*

is a balanced text string, enclosed in parentheses. It may contain nested macro calls, but it may not contain a call to re-`DEFINE` the *macro-name*.

## Discussion

The `DEFINE` macro returns the null string. As a side effect, a call to `DEFINE` creates a new macro call pattern.

`%*DEFINE` specifies at least a name for a programmer-defined macro and the result for a call to the macro. The macro body specifies the return value of the macro call. It may contain nested macro calls, including a call to itself. The return value of a nested macro is the fully expanded macro body, including the return value(s) of its nested macro calls, if any. A macro is expanded each time it is called. After the definition has been fully scanned, the macro name may be redefined with a different macro body.

The literal character (`*`) suppresses the expansion of nested macro calls when the macro processor scans the definition of the macro body. However, `*` does not suppress expansion of macro calls that are nested arguments.

*Param-list* specifies formal parameter identifier(s) to serve as placeholders for argument(s) passed when the new macro is called. Within the macro body, each reference to a parameter identifier must be preceded by the metacharacter. Parameters may be used any number of times and in any order within the macro body. Do not nest a call to an already defined macro if it has the same name as a parameter to the new macro. The macro processor interprets the duplicate identifier as a reference to the parameter.

The macro name and formal parameter list must be enclosed in parentheses. When the macro is called, the corresponding argument list must match the call pattern of the definition: its enclosing and separating delimiters must match those of the definition. Each argument must be balanced text and each may contain nested macro calls.

Within the macro body, each reference to an identifier in *local-list* must be preceded by the metacharacter. However, there is no corresponding argument list for *local-list* when the macro is called. The `LOCAL` construct allows macro identifiers to be expanded into unique assembly time symbols every time the new macro is called.

For every call to a macro with a `LOCAL` construct, the macro processor increments a counter. `LOCAL` symbol references in the macro body are expanded with a 2- to 5-digit suffix that is the current (hexadecimal) value of the counter. For this reason, *local-list* identifiers should be no longer than 26 characters. The suffix is `00` for the first call to a macro with a `LOCAL` construct.

## Examples

1. The following examples show nested macro calls.

```
%*DEFINE (ASTRING) (PHANT)
%*DEFINE (JUMBO) (ELE%ASTRING)
%*DEFINE (TOADY) (SYCO%ASTRING)
:
%JUMBO ; expanded to ELEPHANT
%TOADY ; expanded to SYCOPHANT
```

2. The following example shows two macros defined without parameters or a LOCAL list.

```
%*DEFINE (PROLOG) (
    PUSH EBP
    MOV EBP,ESP
) ; need end line after ESP
%*DEFINE (EPILOG) (
    POP EBP
    RET 8
) ; need end line after 8
:
%PROLOG ; macro calls
:
%EPILOG
```

The return values of these macro calls are:

```
PUSH EBP
MOV EBP, ESP
:
POP EBP
RET 8
```

3. The following example shows two macros, each defined with a formal parameter list.

```
%*DEFINE (PROLOG (VARSIZE)) (
    PUSH EBP
    MOV EBP,ESP
    SUB ESP, %VARSIZE
) ; need end line after VARSIZE
%*DEFINE (EPILOG (POPVAL)) (
    MOV ESP, EBP
    POP EBP
    RET %POPVAL
```

```

    )                ; need end line after POPVAL
    : :
%PROLOG (4)         ; macro calls
    : :
%EPILOG (8)
    : :
%PROLOG (16)
    : :

```

The return values of these macro calls are:

```

PUSH EBP
MOV EBP, ESP
SUB ESP, 4
    : :
MOV ESP, EBP
POP EBP
RET 8
    : :
PUSH EBP
MOV EBP, ESP
SUB ESP, 16
    : :

```

4. The following example shows a macro defined with a LOCAL symbol, LABEL.

```

%*DEFINE (MOVE_ADD_GEN (SOURCE, DEST, COUNT) )
    LOCAL LABEL (
        MOV    ECX, %COUNT
        MOV    ESI, 0
%LABEL:    MOV    EAX, %SOURCE[ESI]
            MOV    %DEST[ESI], EAX
            ADD    ESI, 4
            LOOPZ %LABEL
    )
                ; need end line after LABEL

```

```

: :
: : ; 11th call to a macro
; with LOCAL symbol(s)
%MOVE_ADD_GEN(DATA,FILE,67)

```

The return value of this macro call is:

```

MOV ECX, 67
MOV ESI, 0
LABEL0A: MOV EAX, DATA[ESI]
MOV FILE[ESI], EAX
ADD ESI, 4
LOOPZ LABEL0A

```

## Bracket Macro

### Syntax

```
%(balanced-text)
```

Where:

% represents the current metacharacter.

### Discussion

The macro processor scans the argument to the Bracket in literal scanning mode. The Bracket macro may not be called with the literal character (\*).

The Bracket prevents the macro processor from expanding the *balanced-text* string, except for the following cases:

- The macro processor always expands calls to the Escape and Comment macros.
- The macro processor expands arguments that are nested macro calls (see Example 1 in this section).

See also: Macro arguments, in this chapter

The Bracket prevents the macro processor from evaluating macro calls that are nested in the *balanced-text* argument, including calls to Bracket.

## Examples

1. The following examples illustrate how the macro processor evaluates nested macro calls inside the Bracket.

```
%*DEFINE (STRNG) (DOGS, CATS)
%*DEFINE (NULLMAC ( P1, P2) ) (
:
:
%(%NULLMAC ( %STRNG, MOUSE) )
:
:
%(%NULLMAC ( %(%STRNG), MOUSE) )
```

During its scan of these calls to the Bracket macro, the macro processor expands the *balanced-text* arguments to:

```
:
:
%NULLMAC ( %STRNG, MOUSE)
:
:
%NULLMAC ( %(%STRNG), MOUSE)
```

2. The following macro adds DW statements to the source file. When it is called, the Bracket macro is used to literalize the argument(s) that correspond to the formal parameter LIST. Without the Bracket, the first comma in this argument list would be interpreted as the delimiter separating the two %DW arguments.

```
%*DEFINE (DW (LIST, NAME) ) (
%NAME          DW      %LIST
)                ; need end line after LIST
:
:
%DW (%(1, 2, 3), NUMS)
```

The return value of this call is:

```
NUMS          DW      1, 2, 3
```

## Escape Macro

### Syntax

`%n text`

Where:

`%` represents the current metacharacter.

`n` is a decimal digit from 0 to 9.

`text` is `n` characters long.

## Discussion

The Escape macro interrupts the macro processor in its normal scanning of text. The metacharacter and the decimal digit *n* are not evaluated, but the macro processor scans the next *n* characters as literals. The Escape macro may not be called with the literal character (\*).

Use the Escape to insert a metacharacter as text, to add a comma as part of an argument, or to place a single parenthesis into a character string that requires balanced parentheses.

## Examples

Several examples of the Escape follow the definition of INCMTS.

```
%*DEFINE (INCMTS (ARG1, ARG2, ARG3) )
(
    ; %ARG1
    ; %ARG2
    ; %ARG3
)
: :
; COMPUTE 10%1% OF SUM
%INCMTS (JAN23%1, 86, MAR15%1, 86, APR9%1, 86)
: :
%INCMTS (1%1) +INPUT, 2%1) -20%1%, 3%1) GET NEXT)
```

The expanded text for this fragment is:

```
    ; COMPUTE 10% OF SUM
    ; JAN23, 86
    ; MAR15, 86
    ; APR9, 86
: :
    ; 1) +INPUT
    ; 2) -20%
    ; 3) GET NEXT
```

## Comment Macro

### Syntax

```
%'text end-line
```

or

```
%'text'
```

Where:

`%` represents the current metacharacter

`text` is a character string that may include any character except the apostrophe (') or linefeed; the metacharacter should be literalized within `text`.

`end-line` is the linefeed character (ASCII 0AH) or the carriage return/linefeed combination (ASCII 0D0AH).

### Discussion

The Comment macro always evaluates to the null string, including the terminating delimiter for `text`. The macro processor recognizes two terminating characters: the linefeed and the apostrophe.

The first form of the call spreads macro comments over several lines without inserting extra end line characters into the processed text. The Comment macro may not be called with the literal character (\*).

### Example

The following example of a commented macro definition causes an assembly-time **error** after the macro is called. The macro processor removes the linefeed delimiter as it expands the first comment line in the macro body.

```
.*DEFINE (MOVE_ADD_GEN (SOURCE, DEST, COUNT) )
    LOCAL LABEL
(
    MOV ECX,%COUNT %'COUNT should be constant
    MOV ESI,0
    %LABEL %' %1%LABEL will get hex suffix
    :MOV EAX, %SOURCE[ESI] %'SOURCE is address'
    MOV %DEST[ESI],EAX %'DEST is address'
    ADD ESI,4
    LOOPZ %LABEL %'gets same hex suffix
    %'as the %1%LABEL above'
```

```
)
: :
%MOVE_ADD_GEN(DATA, STOR, 20H)
```

The return value of this call is:

```
MOV ECX, 20H MOV ESI, 0
LABEL07:MOV EAX, DATA[ESI]
MOV STOR[ESI], EAX
ADD ESI, 4
LOOPZ LABEL07
```

After macro processing, the first line has two instructions, which causes an assembler error. The first call to the Comment macro should be terminated with an apostrophe to avoid this error. However, when the comment has been processed in the %Labeled line, the colon is raised to the same line as %LABEL, making it a valid ASM386 instruction.

## METACHAR Macro

### Syntax

```
%METACHAR (balanced-text)
```

Where:

% represents the current metacharacter.

### Discussion

The METACHAR macro redefines the metacharacter. The initial and default metacharacter is %. The leftmost character within the parentheses is interpreted as the new metacharacter. The old metacharacter loses its function after a call to METACHAR; a previously defined macro with nested calls might return its unexpanded macro body as a text string.

The initial character in the argument to METACHAR may be any ASCII character except a logical space (space, tab, linefeed, carriage return), a left or right parenthesis, an identifier character, an asterisk, or a control character (any character with an ASCII value less than 20H).

## Examples

1. The following example changes the metacharacter to !.

```
%METACHAR (!)
```

2. After the following call to `METACHAR`, the backslash becomes the new metacharacter because it is the first character after the left parenthesis.

```
!METACHAR (\&)
```

## EVAL Macro

### Syntax

```
%EVAL (expr)
```

Where:

`%` represents the current metacharacter.

*expr* is a valid expression.

### Discussion

The `EVAL` macro returns its argument's value in hexadecimal digits. A call to `EVAL` returns a value with at least three characters, even if the argument evaluates to a single digit. The leading character is either a minus sign (-) or a decimal digit (0..9); the remaining digits can be any hexadecimal digit (0...F). The last character is the hexadecimal suffix (H).

## Examples

These examples show five calls to `EVAL` followed by the return values.

```
MOV EAX, %EVAL(1 + 1)
COUNT EQU %EVAL(33H + 15H + 0F00H)
ADD EAX,%EVAL(10H - ( (13+6) * 2) + 7)
MOV EAX,%EVAL(%NUM1 LE %NUM2)
MOV AL,%EVAL (1111B EQ 0FH)

MOV EAX, 02H           ; expanded results
COUNT EQU 0F48H
ADD EAX,0FFF1H
MOV EAX,00H           ; 00H = false
MOV AL,-01H          ; -01H = true
```

# SET Macro

## Syntax

```
%SET (macro-name, expr)
```

Where:

`%` represents the current metacharacter.

`macro-name` is a valid identifier.

`expr` is a valid expression.

## Discussion

The SET macro assigns the value of an expression to an identifier and stores the named value in the macro processor symbol table. A subsequent macro call to the identifier returns the value.

SET affects only the macro processor symbol table. When a call to SET is scanned, the macro processor replaces it with the null string in the source file. Symbols defined by SET can be redefined by a subsequent call to SET or to DEFINE. SET is not a reserved macro identifier and it may be redefined; its previous function is then lost.

## Examples

The macro processor inserts no text into the source file for a call to SET. SET assigns a value to a callable identifier in the macro processor's symbol table.

```
%SET (COUNT, 0) ; null string result into source
%SET (OFFSET, 16) ; null string result into source
MOV EAX, %COUNT + %OFFSET ; expands to MOV EAX, 00H + 10H
MOV EBX, %COUNT ; expands to MOV EBX, 00H
: :
%SET (COUNT, %COUNT+%OFFSET) ; null string result into source
%SET (OFFSET, %OFFSET * 2) ; null string result into source
MOV EAX, %COUNT + %OFFSET ; expands to MOV EAX, 10H + 20H
MOV EBX, %COUNT ; expands to MOV EBX, 10H
```

## IF Macro

### Syntax

```
%IF (expr) THEN (balanced-text1) [ELSE (balanced-text2) ] FI
```

Where:

% represents the current metacharacter.

*expr* is a valid expression; its result is interpreted as a logical value.

### Discussion

The IF macro returns expanded results for *balanced-text1* if the expression argument evaluates to true (least significant bit equals 1). An ELSE clause is optional; if it is included, the IF macro returns *balanced-text2* results if the expression argument evaluates to false. IF returns the null string when there is no ELSE clause and the expression argument evaluates to false. FI must terminate the call.

Use the relational operators (EQ, NE, LE, LT, GT, or GE) or the string comparison macros (EQS, NES, LES, LTS, GTS, or GES) to specify an expression argument.

IF calls may be nested; when they are, an ELSE clause refers to the immediately preceding IF call that is still open (not terminated by FI).

### Examples

1. The following examples illustrate an IF call without an ELSE clause and an IF call with an ELSE clause.

```
%IF (0FFH GT %VAR) THEN (MOV EAX, %VAR) FI
%IF (%EQS (ADD EAX, %OPERATION) ) THEN
    (ADD EBX, %R1) ELSE (ADD EBX, %R2) FI
```

2. These examples illustrate nested IF calls. Each IF must be terminated by a matching FI.

```
%IF (%EQS (%OPER, ADD) ) THEN (ADD EAX, DATUM
    ) ELSE (
    %IF (%EQS (%OPER, SUB) ) THEN (SUB EAX, DATUM
    ) ELSE (
    %IF (%EQS (%OPER, MUL) ) THEN (MUL DATUM
    ) ELSE (DIV DATUM
    ) FI
    ) FI
    ) FI
```

3. The following examples contrast calls and results for two conditional macros.

```
%*DEFINE (PROLOG (VARSIZE) ) (
  PUSH EBP
  MOV EBP, ESP
  %IF (%VARSIZE EQ 0) THEN (
    %SET(LEVEL, 0) ) ELSE (
    %SET(LEVEL, 1) %'used in %1%EPILOG'
    SUB ESP, %VARSIZE ) FI
)
%*DEFINE(EPILOG (POPVAL) ) (
  %IF(%EQS(%LEVEL,1) THEN (
    MOV ESP, EBP ) FI
  POP EBP
  RET %POPVAL
)
: :
%PROLOG (4) ; call sets LEVEL = 1
: :
%EPILOG (8)
: :
%PROLOG(0) ; call sets LEVEL = 0
: :
%EPILOG (8)
```

The results of these calls to PROLOG and EPILOG are as follows:

```
PUSH EBP ; 1st %1%PROLOG, LEVEL = 1
MOV EBP, ESP
SUB ESP, 4
: :
MOV ESP, EBP ; 1st %1%EPILOG, LEVEL = 1
POP EBP
RET 8
: :
PUSH EBP ; 2nd %1%PROLOG, LEVEL = 0
MOV EBP, ESP
: :
POP EBP ; 2nd %1%EPILOG, LEVEL = 0
RET 8
```

4. The following example demonstrates the use of `SET` and `IF` for conditional assembly. `%SET (DEBUG, 0)` would turn off the debug code.

```
%SET (DEBUG, 1)
%IF (%DEBUG) THEN (
    MOV EAX,DEBUG_FLAG
    OUT 2,EAX) FI
MOV EBX,OFFSET ARRAY
SUB EBX,1
:   :
```

The following is the expanded result:

```
MOV EAX,DEBUG_FLAG
OUT 2,EAX
MOV EBX,OFFSET ARRAY
SUB EBX,1
```

## WHILE Macro

### Syntax

```
%WHILE (expr) (balanced-text)
```

Where:

`%` represents the current metacharacter.

*expr* is a valid expression; its result is interpreted as a logical value.

### Discussion

The `WHILE` macro returns expanded results as long as the expression argument evaluates to true.

The macro processor first evaluates `WHILE`'s expression argument. If its least significant bit is 1, the balanced text is expanded; otherwise, it is not. Once the balanced text has been expanded, the logical argument is retested; if the least significant bit is still 1, the balanced text is expanded again. This process continues until the logical argument proves false (the least significant bit is 0).

Use the relational operators (`EQ`, `NE`, `LE`, `LT`, `GT`, or `GE`) or the string comparison macros (`EQS`, `NES`, `LES`, `LTS`, `GTS`, or `GES`) to specify an expression argument.

Unless the value of *expr* is modified within the balanced text, the `WHILE` expansion might never terminate. A call to the `EXIT` macro can be used to terminate a `WHILE` expansion.

## Examples

The following examples illustrate calls to `WHILE`.

```
%SET (COUNTER, 5)
:
:
%WHILE (%COUNTER GT 0)
( INC EBX
  %SET (COUNTER, %COUNTER - 1)
)
%WHILE (%COUNT LT 0FFH) (HLT
  %SET (COUNT, %COUNT + 1) )
```

## REPEAT Macro

### Syntax

```
%REPEAT (expr) (balanced-text)
```

Where:

`%` represents the current metacharacter.

*expr* is a valid expression; its value is interpreted as a non-negative integer.

### Discussion

The `REPEAT` macro returns expanded results *expr* times. The macro processor first evaluates the expression argument; then, it expands the balanced text argument the specified number of times. A call to the `EXIT` macro can be used to terminate a `REPEAT` expansion.

## Examples

The following examples perform the same text insertion as the `WHILE` examples. For correct assembly of the expanded text, a linefeed must be coded immediately preceding the right parenthesis that closes each macro body.

```
%REPEAT (5) (INC EBX
)
%REPEAT (0FFH-COUNT) (HLT
)
```

# EXIT Macro

## Syntax

```
%EXIT
```

Where:

% represents the current metacharacter.

## Discussion

The `EXIT` macro terminates expansion of the most recently called `REPEAT`, `WHILE`, or programmer-defined macro. The terminated `REPEAT`, `WHILE`, or macro returns the already expanded text. `EXIT` returns the null string.

Use `EXIT` to avoid infinite loops such as a `WHILE` expression that never becomes false or a recursive macro that never terminates. `EXIT` may be specified more than once in the same macro.

## Examples

1. The following example is a simple jump out of a recursive loop. `BODY` is a macro that modifies `CONDITION` so that `CONDITION` eventually becomes true.

```
%*DEFINE (UNTIL (CONDITION, BODY) )
(%BODY
  %IF (%CONDITION) THEN (%EXIT)
  ELSE (%UNTIL(%CONDITION, %BODY) ) FI
```

2. The following example of `EXIT` terminates a recursive macro when an odd number of bytes have been added. The `M_ADD_M` macro adds paired bytes and stores the results in `DEST`. If there are more than 2 byte pairs to be added, `M_ADD_M` calls itself. Expansion continues as long as `BYTES` is greater than 2. When `BYTES` reaches a value of 1 (odd number of byte pairs), the macro calls `EXIT`.

```
%*DEFINE (M_ADD_M(SRC, DEST, BYTES) ) (
  MOV AL, %SRC
  ADD AL, %DEST
  MOV %DEST, AL
  IF (%BYTES EQ 1) THEN (%EXIT)FI
  MOV AL, %SRC + 1
  ADD AL, %DEST + 1
  MOV %DEST + 1, AL
  IF (%BYTES GT 2) THEN
(%M_ADD_M(%SRC+2, %DEST+2, %BYTES-2) )FI
)
```

# String Comparison Macros

## Syntax

```
%EQS (arg1, arg2)  
%NES (arg1, arg2)  
%LTS (arg1, arg2)  
%GTS (arg1, arg2)  
%LES (arg1, arg2)  
%GES (arg1, arg2)
```

Where:

`%` represents the default metacharacter.  
`args` are balanced text strings; they may contain nested macro calls.

## Discussion

These predefined macros compare two strings and return a logical value based on the comparison. If a string comparison macro evaluates to true, it returns the character string -01H. If it evaluates to false, it returns 00H.

The macro processor expands both arguments completely before making the comparison. Then the ASCII value of the first character in the first string is compared to the ASCII value of the first character in the second string. If they differ, the character with the higher ASCII value determines which string is considered greater.

If the characters are identical, the process continues with the second character in each string, and so on. Only strings of equal length that contain the same characters in the same order are equal. If one string is a proper initial substring of the other, it is less than the other.

The following list describes each string comparison macro:

|     |                                                                                                                                 |
|-----|---------------------------------------------------------------------------------------------------------------------------------|
| EQS | Equal: true if both arguments are identical                                                                                     |
| NES | Not equal: true if arguments are different in any way                                                                           |
| LTS | Less than: true if first argument precedes second argument in dictionary ordering                                               |
| GTS | Greater than: true if first argument follows second argument in dictionary ordering                                             |
| LES | Less than or equal: true if first argument precedes second argument in dictionary ordering or if both arguments are identical   |
| GES | Greater than or equal: true if first argument follows second argument in dictionary ordering or if both arguments are identical |

## Examples

1. These examples illustrate calls to each string comparison macro commented with results.

```
%GTS(16D,11H)    %' -01H (true: ASCII 6 > 1) '  
%EQS(ABC,ABC)   %' -01H (true: strings identical) '  
%EQS(ABC, ABC)  %' 00H (false: space character  
                %' in second argument) '  
%LTS(CBA, cba)  %' -01H (true: ASCII C < c) '  
%GES(ABCDEF,ABCDEF )  
                %' 00H (false: additional  
                %' space in second argument) '
```

2. Like any other macro, the string comparison macros accept nested macros as arguments. The result of the following call to EQS is -01H (true).

```
.*DEFINE(DOG) (CAT)  
.*DEFINE(MOUSE) (%DOG)  
%EQS(%DOG,%MOUSE)
```

## LEN Macro

### Syntax

```
%LEN (balanced-text)
```

Where:

% represents the current metacharacter.

### Discussion

The LEN macro returns the length of its balanced text argument in hexadecimal. The expanded argument may have from 0 to 255 characters.

## Examples

These examples illustrate four calls to LEN commented with results.

```
%LEN(ABCDEFGHIJKLMNPOQRSTUVWXYZ)  
                %' 1AH '  
%LEN(A,B,C)     %' 05H (commas are counted) '  
%LEN()          %' 00H '  
.*DEFINE(CHEESE) (MOUSE)  
.*DEFINE(DOG) (CAT)  
%LEN(%DOG %CHEESE)  
                %' 09H (space between expanded  
                %' %1%DOG %1%CHEESE counted) '
```

# SUBSTR Macro

## Syntax

```
%SUBSTR (balanced-text, expr1, expr2)
```

Where:

- % represents the current metacharacter.
- expr1* is a valid expression; its value is an index to the initial character of the substring.
- expr2* is a valid expression; its value is a count of the number of characters to be included in the substring.

## Discussion

SUBSTR returns a substring of its balanced text argument. *Expr1* specifies the starting character of the substring and *expr2* specifies the number of characters to be included in the substring.

SUBSTR operates as follows:

- If *expr1* is 0 or it is greater than the length of the argument string, SUBSTR returns the null string.
- If *expr2* is 0, SUBSTR returns the null string.
- If *expr2* is greater than the remaining length of the string, all characters from the first character of the substring to the end of the string are included.

## Examples

These examples illustrate four calls to SUBSTR, commented with results.

```
%SUBSTR (ABCDEFGH, 5, 1)      %' E '  
%SUBSTR (ABCDEFGH, 5, 100)   %' EFG '  
%SUBSTR (123 (56) 890, 4, 4) %' (56) '  
%SUBSTR (ABCDEFGH, 8, 1)     %' null '  
%SUBSTR (ABCDEFGH, 3, 0)     %' null '
```

# MATCH Macro

## Syntax

```
%MATCH ( [name1] delim name2 [delim nameN]...[delim] ) (balanced-text)
```

Where:

*%* represents the current metacharacter.

*names* are valid identifiers.

*delims* are delimiters; the initial character of each *delim* may not be a valid identifier character.

## Discussion

The `MATCH` macro returns the null string. As a side effect, `MATCH` adds callable macro identifiers to the macro symbol table. Each newly defined macro has a value that is either a substring of the balanced text argument or the null string.

When it encounters a call to `MATCH`, the macro processor discards logical spaces between the left parenthesis and the initial non-blank character of the balanced text argument. Then, it searches the balanced text for the leftmost delimiter of `MATCH`'s other argument.

If this delimiter is found, the macro processor assigns the characters to the left of *delim* to *name1* or it discards these characters if *name1* is omitted. The macro processor continues searching the balanced text argument for the next-specified delimiter and assigns the substring between the preceding *delim* and this *delim* to *name2*, and so forth.

Whenever a specified delimiter cannot be matched, the macro processor assigns the remaining balanced text to *name(N - 1)*. It assigns the null string to any remaining names.

## Example

This example illustrates calls to `MATCH` and `WHILE`.

```
%MATCH(NEXT,LIST) (10H,20H,30H)
MOV ESI, VAR_PTR
%WHILE(%LEN(%NEXT)NE 0) (
MOV EBX, %NEXT
MOV EAX, [EBX+ESI]
ADD EAX, 22H
MOV [EBX+ESI], EAX
%MATCH(NEXT,LIST) (%LIST)
)
```

After the call to MATCH, the %WHILE expands as follows:

```
MOV EBX, 10H           ; 1st iteration of WHILE
MOV EAX, [EBX+ESI]
ADD EAX, 22H
MOV [EBX+ESI], EAX
MOV EBX, 20H           ; 2nd iteration of WHILE
MOV EAX, [EBX, +ESI]
ADD EAX, 22H
MOV [EBX+ESI], EAX
MOV EBX, 30H           ; 3rd iteration of WHILE
MOV EAX, [EBX+ESI]
ADD EAX, 22H
MOV [EBX+ESI], EAX
```

## Console I/O Macros

### Syntax

%IN

%OUT (balanced-text)

%CI

%CO (char)

Where:

% represents the current metacharacter.

### Discussion

The IN, OUT, CI, and CO macros perform console input and output. IN and OUT are line-oriented macros. CI and CO are character-oriented macros.

IN sends the characters >> as a prompt to the console and returns the next line typed at the console, including the line terminator. OUT sends a string to the console; the return value of OUT is the null string.

CI returns a single character typed at the console; CI neither prompts for input nor echoes the character typed. CO sends a single character to the console; the return value of CO is the null string. If the %CO argument has more than one character, only the first character is sent.

## Examples

1. This example illustrates calls to IN and OUT.

```
%OUT(HOW MANY PROCESSORS IN SYSTEM?)
%SET(PROC_COUNT, %IN)
%OUT (WHAT'S THIS PROCESSOR'S ADDRESS?)
ADDRESS EQU %IN
%OUT (WHAT'S THE BAUD RATE?)
%SET(BAUD, %IN)
```

These macro calls return the following results to the console:

```
HOW MANY PROCESSORS IN SYSTEM?>> response
WHAT'S THIS PROCESSOR'S ADDRESS?>> response
WHAT'S THE BAUD RATE>> response
```

2. This example defines the macro NUMBER as a string of three characters typed at the console and echoes the characters as they are typed.

```
%DEFINE (NUMBER) ( )
%REPEAT (3) (%DEFINE (A) (%CI) %CO (%A)
%DEFINE (NUMBER) (%NUMBER%A) )
```

# Scanning Modes, Delimiters, and Macro Expansions

This section explains scanning modes, delimiters, and macro expansions in greater detail than the Overview section.

## Normal and Literal Scanning Modes

In normal mode, the macro processor scans text for the metacharacter. When it finds one, it begins expanding the macro call. If it encounters a macro definition containing nested calls, the macro processor expands them in the process of defining the new macro.

In the definition of a macro body, the metacharacter precedes each reference to a formal parameter and/or `LOCAL` symbol. In normal mode, the macro processor attempts to evaluate such references as parameterless macro calls.

When the literal character (\*) is placed in a call to `DEFINE`, the macro processor shifts to literal scanning mode. As it scans the `%*DEFINE` arguments, the macro processor always expands Escape and Comment calls, whatever the current scanning mode. It expands Bracket calls that are not nested in other Bracket calls. The macro processor also expands nested macro calls that are arguments unless they are literalized with Escape or Bracket.

Whatever the scanning mode for a call to `DEFINE`, the macro processor inserts the null string into the source file that it passes on to the assembler. The assembler generates a listing file (by default) and merges in the macro processor's intermediate listing file if appropriate controls are specified.

See also: Listing file, *ASM386 Macro Assembler Operating Instructions*

The following examples illustrate the differences between how the macro processor handles macro definitions and calls in literal and normal scanning modes.

Compare the definitions of AB and CD:

```
%SET (CARP,1)           ; null string into source
%*DEFINE (AB) (%EVAL(%CARP) ) ; literal mode scan
%DEFINE (CD) (%EVAL(%CARP) ) ; normal mode scan:
                          ; %1%CD:= 01H
                          ; in macro symbol table,
                          ; null string into source
```

The macro processor does not evaluate `%EVAL(%CARP)` in the body of AB, but it expands the macro body of CD completely because the literal (\*) character is not used in the definition. If the value of `CARP` changes, it has no effect on subsequent calls to CD. However, a new value for `CARP` does affect subsequent calls to AB.

For example:

```
%SET(CARP,2)           ; null string into source
%AB                     ; returns 02H
%CD                     ; returns 01H (unless CD was redefined)
```

Macros may be called with the literal character. For example:

```
%*CD                   ; returns 01H
%*AB                   ; returns %EVAL(%CARP)
```

The literalized call to AB returns the definition of its macro body. Both literal and normal mode calls to CD return 01H because the macro processor expanded the original CD definition fully in normal scanning mode.

## Macro Delimiters

Only the delimiters used in the definition of a macro can be used in a call to that macro. When the macro processor scans a definition's formal parameter list, the delimiters are stored in the macro symbol table as part of that macro's call pattern. When the macro processor scans the call, it searches for these delimiters to isolate each argument string for evaluation.

There are three kinds of macro delimiters: literal delimiters, implied blank delimiters, and identifier (or ID) delimiters.

### Literal Delimiters

A literal delimiter may be any single character except the metacharacter. However, literal delimiters defined with more than one character, or with an unbalanced parenthesis, a logical space, the at character (@), or an identifier character must be literalized every time they are used.

Literalize the delimiter string with the Bracket or Escape macro if the literal delimiter includes any of the following:

- More than one character
- An unbalanced left or right parenthesis
- A...Z, a..z, 0...9, underbar (\_), or question mark (?)
- An at character (@)
- A space, tab, carriage return, or linefeed

Following are some examples of definitions and calls using a variety of literal delimiters:

#### Before Macro Expansion

```
%*DEFINE (MAC (A, B) ) (%A %B)
%MAC (4, 5)
%*DEFINE (MOV [A% (@) B]) (MOV [%A], %B)
%MOV [BX @ DI]
%*DEFINE (ADD (A% (AND) B) ) (ADD %A, %B)
%ADD (AX AND 5)
```

```
%*DEFINE (ADD P1 %(TO) P2 %(AND) P3)
( null string into source
MOV EAX, %P1
MOV EBX, EAX
ADD EAX, %P2
MOV %P2, EAX
MOV EAX, EBX
ADD EAX, %P3
MOV %P3, EAX
)
```

```
%ADD COUNT TO INCR AND FACTOR
MOV EBX, EAX
ADD EAX, INCR
MOV INCR, EAX
MOV EAX, EBX
ADD EAX, FACTOR
MOV FACTOR, EAX
```

#### After Macro Expansion

```
null string into source
4 5
null string into source
MOV [BX], DI
null string into source
ADD AX, 5
```

```
MOV EAX, COUNT
```

## Implied Blank Delimiters

An implied blank delimiter is one or more spaces, tabs, or end lines (a carriage return/linefeed pair or just a linefeed) specified between parameters. To define a macro only with implied blank delimiters, place one or more spaces, tabs, or end lines preceding the formal parameter list and between each parameter.

When calling such a macro, match each delimiter with a series of spaces, tabs, or end lines. Each argument to the call begins with the first nonblank character and ends at the next logical space.

Consider the following macro definition:

```
%*DEFINE (SENTENCE SUBJ VERB OBJ) (  
    THE %SUBJ %VERB %OBJ.  
)
```

All of the following calls are valid for this macro:

### Before Macro Expansion

```
%SENTENCE TIME IS RIPE  
%SENTENCE CATS  
    EAT  
    MICE  
%SENTENCE  
    PEOPLE  
LIKE        CATS
```

### After Macro Expansion

```
THE TIME IS RIPE.  
  
THE CATS EAT MICE.  
  
THE PEOPLE LIKE CATS.
```

Implied blank delimiters may be used as enclosing and/or separating delimiters, mixed with other kinds of delimiters. The terminating blank delimiter may be omitted in the definition of a formal parameter list, but it may not be omitted in the corresponding argument list when the macro is called.

## Identifier Delimiters

Identifier (or ID) delimiters are macro identifiers designated as separating delimiters. To define an ID delimiter, specify the at character (@) followed immediately by the delimiter character(s). Separate each ID delimiter from the formal parameter identifiers with logical spaces. When calling a macro with ID delimiters, substitute an implied blank delimiter for the @ and specify only the identifier characters of each ID delimiter. Separate each ID delimiter from the arguments with logical spaces.

Consider the following macro definition:

```
%*DEFINE (ADD P1 @TO P2 @AND P3) (  
    MOV EAX, %P1  
    MOV EBX, EAX  
    ADD EAX, %P2  
    MOV %P2, EAX  
    MOV EAX, EBX  
    ADD EAX, %P3  
    MOV %P3, EAX  
)
```

Compare the following calls:

```
%ADD ATOM TO MOLECULE AND CRYSTAL  
%ADD ATOM TO MOLECULE AND CRYSTAL
```

Both calls are valid. Each returns the following code when expanded

```
MOV EAX, ATOM  
MOV EBX, EAX  
ADD EAX, MOLECULE  
MOV MOLECULE, EAX  
MOV EAX, EBX  
ADD EAX, CRYSTAL  
MOV CRYSTAL, EAX
```

but the second call adds extra logical spaces between some operands.

## Algorithm for Evaluating Macro Calls

The macro processor uses the following steps to evaluate the source file:

1. Scan the source input stream until the metacharacter is found.
2. Isolate the call pattern (see the following Note).
3. Expand each argument, if any, from left to right before expanding the next; go back to Step 1 if an argument has a nested macro call.
4. Substitute the expanded arguments for their corresponding formal parameters in the macro body.
5. Initiate Step 1 on the macro body if the literal character is not used.
6. Enter any newly defined macro identifiers and call pattern(s) into the macro processor symbol table and/or update already defined symbols.
7. Insert the result into the output stream and go to Step 1.



### Note

When isolating the macro name and the argument(s) in a call pattern, the macro processor is actually scanning input for the next specified delimiter. The text between delimiters is considered to be the macro name or an argument.

The terms input stream and output stream are used because the return value of one macro can be an argument of another macro. On the first iteration, the input stream is the source file. On the final iteration, the output stream is passed as source to the assembler.

Consider the following macro definitions:

```
%SET (BASS, 3)
%*DEFINE (CARP) (%SET (BASS, %BASS - 1) %BASS)
%*DEFINE (PIKE (A, B)) (
DB %A, %B, %A, %B, %A, %B
)
```

The following macro calls illustrate how the macro processor evaluates nested calls that are arguments and expands them in their caller's macro body.

#### Before Macro Expansion

```
%PIKE (%BASS, %CARP)
%SET (BASS, 3)
%PIKE (%CARP, %BASS)
%SET (BASS, 3)
%PIKE (%*CARP, %BASS)
```

#### After Macro Expansion

```
DB 03H, 02H, 03H, 03H, 02H
DB 02H, 02H, 02H, 02H, 02H, 02H
DB 02H, 03H, 01H, 03H, 00H, 03H
```

The first call to `PIKE` has `%BASS` as the first argument and `%CARP` as the second. The macro processor expands the call to `%BASS` before it evaluates the second argument. After the call to `%PIKE` has been completely expanded, `BASS` has the value `02H` because its value was `reSET` during the expansion of `%CARP`.

The second call to `PIKE` reverses the order of the arguments. The macro processor expands `%CARP` first; thus, it decrements `%BASS` before it evaluates `%BASS` as the second argument to `%PIKE`. Both `%PIKE` arguments have the same value when the macro processor substitutes them into the macro body.

The third call to `PIKE` has a literal call (`%*CARP`) as its first argument; the result of the literal mode call is the defined macro body of `CARP`: `%SET(BASS, %BASS-1) %BASS`. The macro processor substitutes this result for each `%A` in the macro body of `PIKE`.

Then, the macro processor evaluates the second argument to `PIKE`: a call to `%BASS` in normal scanning mode. `%BASS` is fully expanded to `03H`. The macro processor substitutes this result for each `%B` in `PIKE`'s macro body.

As the macro processor expands `PIKE`'s macro body, it evaluates `%SET (BASS, %BASS - 1) %BASS` three times, once for each reference to `%A` in the definition of `PIKE`.

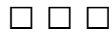

# Codemacros 9

---

This chapter describes the assembler codemacro directives and the function `PROCLLEN`. It has three major sections:

- **Overview**  
Explains what codemacros are, briefly describes their definition and calls, and includes reference illustrations of the processor instruction encoding formats.
- **Codemacro Reference**  
Explains the codemacro directives, the dot record field shift construct, and the function `PROCLLEN` in detail.
- **Matching Codemacro Calls to Their Definitions**  
Explains how the assembler determines that a codemacro call matches a definition and/or matches a particular definition when more than one codemacro is defined with the same name.

## Overview

Codemacros are defined bodies of code that act like assembler instructions and instruction prefixes when they are called. A codemacro is called when its name is used as an instruction.

## Codemacro Definitions and Calls

The `CODEMACRO` directive defines a codemacro. A codemacro definition tells the assembler how to generate object code for the codemacro when it is called. The codemacro name, followed by appropriate operands (if any) is the codemacro call. Thus, codemacro definitions either redefine assembler instructions or create new instructions. However, you cannot invent new instructions that are not supported by the processor or by the processor and floating-point coprocessor.

Most directives and values within a codemacro definition are fixed, but a definition may specify formal parameters as placeholders for operands to be supplied at the codemacro call. Like many assembler instructions, a codemacro may be called with various kinds of operands. For example, a codemacro might be called first with an immediate source operand and an implicit register as the destination. The same codemacro might be called next with a register source operand and an explicit memory destination.

Such a codemacro must be defined more than once with the same name but with different kinds of formal parameters for each definition. Multiple definitions of the same codemacro name are linked by the assembler. When such a codemacro is called, the assembler checks each definition for a match of operands and generates appropriate object code when it finds a match.

The body of a codemacro is located between the first and last lines of its definition. For a simple codemacro definition without formal parameters, the body tells the assembler what opcode to generate when the codemacro is called. For more complex codemacros, the body tells the assembler how to construct and fill the processor instruction format fields

See also:     Parameter-operand matching, in this chapter  
              Processor instruction format, in this chapter

A codemacro body may contain the following directives:

- PREFIX66
- PREFIX67
- SEGFIX
- NOSEGFIX
- WARNING
- DB, DW, DD, and DP, the data initialization directives
- The record initialization directive
- RELB, RELW, and RELD, the relative displacement directives
- MODRM

PREFIX66, PREFIX67, SEGFIX, NOSEGFIX, WARNING, RELB, RELW, RELD, and MODRM are valid assembler statements only within codemacro bodies. The DB, DW, DD, DP, and record initialization directives accept only codemacro expression arguments within codemacro bodies.

See also: DB, DW, DD, and DP as data storage allocation directives, Chapter 4

The next section of this chapter includes a detailed reference for each directive. It also explains using the dot record field shift construct and the special expression function PROCLLEN within codemacro definitions.

## Processor Instruction Format

Codemacro definitions tell the assembler how to generate object code when the codemacro is called. The codemacro directives control the generation of processor instruction encodings.

Figure 9-1 illustrates the general encoding format for processor instructions.

| Instruction Prefix | Address-size Prefix | Operand-size Prefix | Segment Override |
|--------------------|---------------------|---------------------|------------------|
| 0 or 1             | 0 or 1              | 0 or 1              | 0 or 1           |
| Number of Bytes    |                     |                     |                  |

| Opcode          | ModRM  | SIB    | Displacement | Immediate    |
|-----------------|--------|--------|--------------|--------------|
| 1 or 2          | 0 or 1 | 0 or 1 | 0, 1, 2 or 4 | 0, 1, 2 or 4 |
| Number of Bytes |        |        |              |              |

W-3436

**Figure 9-1. Instruction Encoding Format**

Certain codemacro directives control the encoding of particular fields:

- `CODEMACRO` determines whether a call generates an `INSTRUCTION PREFIX` byte or a full instruction encoding, possibly with operands, for the named codemacro.
- `PREFIX67` tells the assembler to generate an `ADDRESS SIZE PREFIX` byte, if necessary.
- `PREFIX66` tells the assembler to generate an `OPERAND SIZE PREFIX` byte, if necessary.
- `SEGFIX` tells the assembler to generate a `SEGMENT OVERRIDE` prefix byte, if necessary.
- `DB` or `DW` specifies the value for the `OPCODE` byte(s).
- `MODRM` tells the assembler how to construct any necessary `ModRM` and `SIB` bytes (see Figure 9-2).

The data initialization, record initialization, dot-shift construct, `PROCLLEN` and relative displacement directives are used in conjunction with formal parameters to tell the assembler how to generate instruction bytes. The `CODEMACRO` directive may specify a formal parameter whose matching operand requires one or more displacement bytes; it also may specify a formal parameter whose matching operand is an immediate value.

Figure 9-2 illustrates the encoding formats of the `ModRM` and `SIB` bytes.

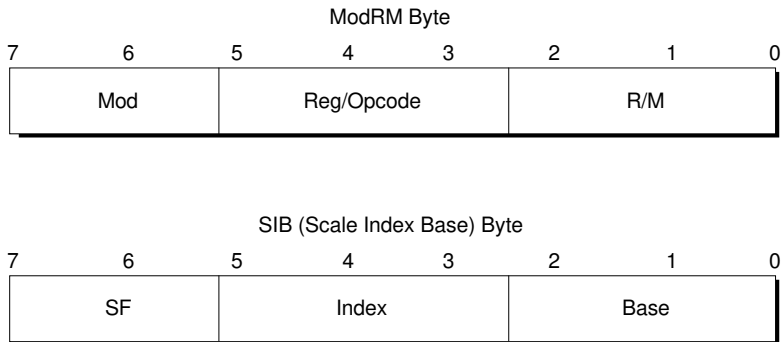

W-3423

**Figure 9-2. ModRM and SIB Byte Formats**

The `ModRM` byte specifies the addressing form for operand(s). Certain encodings of the `ModRM` byte indicate that a `SIB` (Scale Index Base) byte follows the `ModRM` byte to fully specify the addressing form. To summarize the `ModRM` and `SIB` fields:

- `MOD`        combines with the `R/M` field to form 32 possible values representing 8 general registers and 24 indexing modes.
- `REG`        specifies either a register number or 3 more bits of `OPCODE` information; the first `OPCODE` byte (see Figure 9-1) determines the meaning of the `REG` field.
- `R/M`        specifies an operand location either as a register number or as a memory address (in combination with the `MOD` field).
- `SF`        specifies a scale factor (1, 2, 4, or 8) for an operand with a scaled indexed address.
- `INDEX`     specifies the register number of the index register for an operand with a based indexed or scaled indexed address.

`BASE` specifies the register number of the base register for an operand with a based, based indexed, or based indexed and scaled address.

The `MODRM` directive tells the assembler how to generate `ModRM` and `SIB` bytes.

See also: Chapter 5 for more information about indirect memory addressing, including the processor rules about base and index registers for 32- and 16-bit addressing  
Chapter 6 for tables of `ModRM` and `SIB` values for the 16- and 32-bit addressing forms.

# Codemacro Reference

Table 9-1 summarizes the syntax for assembler codemacro directives, the record field shift construct, and the PROCLen function.

**Table 9-1. Codemacro Syntax Summary**

|               |                                                                                                |
|---------------|------------------------------------------------------------------------------------------------|
| CODEMACRO     | CODEMACRO <i>cmac-name</i> [ <i>formal</i> ] [, <i>formal</i> ]...<br><i>cmac-body</i><br>ENDM |
| <i>formal</i> | <i>fparam:specifier</i> [ <i>modifier</i> ] [ ( <i>range</i> ) ]                               |
| or            | CODEMACRO <i>cmac-name</i> PREFIX<br><i>cmac-body</i><br>ENDM                                  |
| PREFIX67      | PREFIX67 <i>fparam</i>                                                                         |
| PREFIX66      | PREFIX66 [PTR,] <i>fparam</i>                                                                  |
| SEGFIX        | SEGFIX <i>fparam</i>                                                                           |
| NOSEGFIX      | NOSEGFIX <i>Sreg</i> , <i>fparam</i>                                                           |
| WARNING       | WARNING                                                                                        |
| MODRM         | MODRM <i>fp/num</i> , <i>fparam</i>                                                            |
| DB            | DB <i>cmac-expr</i>                                                                            |
| DW            | DW <i>cmac-expr</i>                                                                            |
| DD            | DD <i>cmac-expr</i>                                                                            |
| DP            | DP <i>cmac-expr</i>                                                                            |
| Record        | <i>rec-name</i> [ < <i>cmac-expr</i> [...]> ]                                                  |
| Dot-shift     | <i>fparam.rec-field</i>                                                                        |
| PROCLen       | PROCLen                                                                                        |
| RELB          | RELB <i>fparam</i>                                                                             |
| RELW          | RELW <i>fparam</i>                                                                             |
| RELD          | RELD <i>fparam</i>                                                                             |

The following subsections are a detailed reference for each item in Table 9-1.

# CODEMACRO Directive

## Syntax

```
CODEMACRO cmac-name [formal] [, formal]...  
    cmac-body  
ENDM
```

or

```
CODEMACRO cmac-name PREFIX  
    cmac-body  
ENDM
```

### Where:

*cmac-name* is a valid identifier or an instruction mnemonic. The same name may be specified for more than one CODEMACRO statement in the module; otherwise, it must be unique within the module.

*formal* is a formal parameter, specified as follows:

```
fparam:specifier[modifier] [ (range) ]
```

*cmac-body* contains at least one codemacro directive. *cmac-body* may not contain a nested CODEMACRO directive or a codemacro call.

See also: Identifiers, Chapter 1  
instruction mnemonic keywords, Appendix C

## Discussion

The CODEMACRO statement defines a codemacro. A codemacro definition begins with a line specifying its name and an optional list of up to 15 formal parameters. ENDM must terminate the definition. A codemacro definition may cause the generation of up to 255 bytes per codemacro call.

CODEMACRO statements may be specified anywhere after the NAME statement in an assembler source module. However, it is an error to call a codemacro as a forward reference, to call a codemacro defined in another module, or to call a codemacro within *cmac-body*.

A codemacro may have the same name as an assembler instruction or prefix. If a codemacro has the same name and same kinds of operands as an instruction, the assembler processes the codemacro instead of the instruction when it encounters that name.

If a codemacro is defined with the same name as an instruction but with different kinds of operands, the assembler processes the codemacro only if the given operands match those of the codemacro definition; otherwise, it processes the instruction of that name.

Codemacros with formal parameters must use parameter names that follow the same rules as other identifiers. Each formal parameter must be followed by a *specifier* (A, C, D, E, F, M, R, S, T, or X). A specifier indicates the kind of operand that matches the corresponding formal parameter when the codemacro is called. An optional *modifier* (BIT, B, W, D, DN, P, Q, or T) and/or range specifier impose(s) further requirements on the codemacro operand.

The reserved word `PREFIX` indicates that the codemacro will be used as an instruction prefix, much as `LOCK` and `REP` are used. Codemacros defined with `PREFIX` may not have formal parameters.

## Examples

1. This example defines a new mnemonic for the processor `FSIN` instruction.

```
CODEMACRO SINE
    DW 0D9FEH          ; opcode
ENDM SINE
```

2. The following examples parallel three `ADD` instructions. Each has two formal parameters, `DST` and `SRC`. Each matches different kinds of destination and source operands, as indicated by the comments.

```
CODEMACRO ADD DST:AB, SRC:DB
    DB 04H            ; DST = AL
    DB SRC            ; SRC = immediate byte value
ENDM ADD
```

```
CODEMACRO ADD DST:AW, SRC:DW
    DB 05H            ; DST = AX
    DW SRC            ; SRC = immediate word value
ENDM ADD
```

```
CODEMACRO ADD DST:AD, SRC:DD
    DB 05H            ; DST = EAX
    DD SRC            ; SRC = immediate dword value
ENDM ADD
```

- This example duplicates the function of the LOCK instruction prefix.

```
CODEMACRO LOCK PREFIX
    DB 11110000B
ENDM
```

## Formal Parameters and Specifiers

### Syntax

*fparam*: *specifier*[*modifier*] [ (*range*) ]

Where:

*fparam* is a valid identifier; *fparam* must be unique within the codemacro definition.

*specifier* is one of the letters A, C, D, E, F, M, R, S, T, or X.

See also: Valid identifiers, Chapter 1

### Discussion

Every formal parameter must have a specifier letter that indicates which kind of codemacro operand matches the parameter:

| Formal Specifier | Matching Operand(s)                                                                                                          |
|------------------|------------------------------------------------------------------------------------------------------------------------------|
| A                | Accumulator: EAX, AX, or AL register                                                                                         |
| C                | Code: label expression only                                                                                                  |
| D                | Data: integer used as an immediate operand                                                                                   |
| E                | Effective Address: a general register, a bracketed register expression, or a variable with or without indexing               |
| F                | Floating-point Stack Element: ST or ST( <i>i</i> ) where <i>i</i> is a digit from 0 to 7                                     |
| M                | Memory Address: either a bracketed register expression or a variable with or without indexing                                |
| R                | Register: general register only -- not an address expression, a bracketed register, or a segment, debug, or control register |
| S                | Sreg: CS, DS, ES, FS, GS, or SS segment register                                                                             |
| T                | Floating-point Stack Top: ST or ST(0)                                                                                        |
| X                | Direct Memory Reference: a simple variable name with no index or base register                                               |

See also: Operand-specifier matching, in this chapter

## Formal Parameter Modifiers

### Syntax

*fparam:specifier[modifier] [ (range) ]*

Where:

*modifier* is BIT, B, W, D, DN, P, Q, or T; a space between a specifier and modifier is an error.

### Discussion

The optional modifier imposes another requirement on a codemacro operand, relating either to the size of data being manipulated or to the amount of code generated for the operand.

The meaning of the modifier depends on the operand, as follows:

- If the operand is an immediate (D specifier), the modifier depends on the range of acceptable values:

| <b>Modifier</b> | <b>Value in Range</b>         |
|-----------------|-------------------------------|
| B               | -255..255                     |
| W               | -65535..65535                 |
| D               | $-(2^{31} - 1)..(2^{31} - 1)$ |

Immediate operands must have values that fit in one of these ranges; the specifier-modifier pairs DBIT, DP, DQ, and DT are invalid.

- If the operand is a label (C specifier), the modifier depends on the type and sometimes on the distance jumped or USE attribute:

| <b>Modifier</b> | <b>Label of Type</b>                        |
|-----------------|---------------------------------------------|
| B               | 8-bit relative displacement on a NEAR label |
| W               | NEAR labels in USE16 segments               |
| DN              | NEAR labels in USE32 segments               |
| D               | FAR labels in USE16 segments                |
| P               | FAR labels in USE32 segments                |

- If the operand is a variable, the modifier depends on the type:

| <b>Modifier</b> | <b>Variable of Type</b> |
|-----------------|-------------------------|
| BIT             | BIT                     |
| B               | BYTE                    |
| W               | WORD                    |
| D               | DWORD                   |
| P               | PWORD                   |
| Q               | QWORD                   |
| T               | TBYTE                   |

## Examples

1. This codemacro accepts an immediate operand whose value must fit in a byte. It also redefines the mnemonic for one of the `PUSH` instructions.

```
CODEMACRO PUSHBYTE SRC:DB(-128,127)
    DB 6AH
    DB SRC
ENDM
```

2. The following codemacros accept only operands that are assembler procedures of type `NEAR`. The specifier-modifier pairs `CW` and `CDN` are matched by an operand that is a `PROC` label in the same segment. The `RELW` and `RELD` directives cause a displacement of 16-bits (`USE16` segment) and 32-bits (`USE32` segment), respectively.

```
CODEMACRO CALL ADDR: CW
    DB 0E8H
    RELW ADDR
ENDM
```

```
CODEMACRO CALL ADDR: CDN
    DB 0E8H
    RELD ADDR
ENDM
```

3. The following codemacro accepts an operand that is the address of a byte in memory.

```
CODEMACRO XLAT TABLE: MB
    PREFIX67 TABLE
    SEGFIX TABLE
    DB 0D7H
ENDM
```

# Formal Parameter Range Specifiers

## Syntax

*fparam:specifier[modifier] [ (range) ]*

Where:

*specifier* must be A, D, R or S.

*range* is either a single expression enclosed in parentheses or two expressions separated by a comma and enclosed in parentheses.

## Discussion

The optional range specifier imposes another requirement on a codemacro operand: its value must match the specified expression or its value must lie within the inclusive range of both expressions.

A range expression must evaluate to a register or to a signed integer. Range specifiers that are register names have the following binary values:

| Value | For Registers   |
|-------|-----------------|
| 000   | EAX, AX, AL, ES |
| 001   | ECX, CX, CL, CS |
| 010   | EDX, DX, DL, SS |
| 011   | EBX, BX, BL, DS |
| 100   | ESP, SP, AH, FS |
| 101   | EBP, BP, CH, GS |
| 110   | ESI, SI, DH     |
| 111   | EDI, DI, BH     |

A range expression may not include a symbolic address.

## Example

The following is the first line of a sample codemacro, `IN`, that uses a range specifier. For a call to this codemacro, only `DX` can be used as the port from which to input a `WORD`.

```
CODEMACRO IN DST:AW,PORT:RW(DX)
```

## PREFIX67 Directive

### Syntax

```
PREFIX67 fparam
```

Where:

*fparam* is the name of a formal parameter with a C, E, M, or X specifier.

### Discussion

PREFIX67 generates an address size prefix byte (67H) for an operand whose addressing mode is different from the USE attribute of the current segment.

### Example

This codemacro accepts an operand that is the address of a byte in memory. For an assembler codemacro call, the assembler always generates a 32- or 16-bit address. PREFIX67 tells the assembler to generate an address size prefix byte (see Figure 9-1) if the codemacro is called from a code segment with a different USE attribute than the operand's defining segment.

```
CODEMACRO XLAT TABLE:MB
    PREFIX67 TABLE
    SEGFIX TABLE
    DB 0D7H
ENDM
```

## PREFIX66 Directive

### Syntax

```
PREFIX66 [PTR, ] fparam
```

Where:

*fparam* is the name of a formal parameter with an A, C, E, M, R, or X specifier and a P (C specifier only), D, or W modifier.

## Discussion

The `PREFIX66` directive instructs the assembler to generate an operand size prefix byte (66H), depending on the operand's ASM386 type and the `USE` attribute (`USE32` or `USE16`) of the current segment. `PTR` tells the assembler to compare `DWORD` and `PWORD` operands against the `USE` attribute of the current segment.

If the optional `PTR` is omitted, the assembler generates the 66H prefix under the following conditions:

- The operand is of type `WORD` and the current segment is `USE32`.
- The operand is of type `DWORD` and the segment is `USE16`.

If `PTR` is specified, the assembler generates the 66H prefix under the following conditions:

- The operand is of type `DWORD` and the current segment is `USE32`.
- The operand is of type `PWORD` and the segment is `USE16`.

## Examples

The second and third codemacro definitions tell the assembler to generate an operand size prefix byte (see Figure 9-1) if the operand matched to `DVSR` was defined in a segment with a different `USE` attribute than the current segment.

```
CODEMACRO CMDIV DVSR:EB
  PREFIX67 DVSR
  SEGFIX DVSR
  DB 0F6H
  MODRM 6, DVSR
ENDM
```

```
CODEMACRO CMDIV DVSR:EW
  PREFIX67 DVSR
  PREFIX66 DVSR
  SEGFIX DVSR
  DB 0F7H
  MODRM 6, DVSR
ENDM
```

```

CODEMACRO CMDIV DVSR:ED
    PREFIX67 DVSR
    PREFIX66 DVSR
    SEGFIX DVSR
    DB 0F7H
    MODRM 6, DVSR
ENDM

```

The preceding examples are the functional equivalent of the `DIV` instructions. The `CMDIV` codemacro definitions must be coded as shown (small-to-large operand ordering) so that the assembler matches a call to `CMDIV` with the appropriate definition.

See also: Call-definition matching, in this chapter

## SEGFIX Directive

### Syntax

```
SEGFIX fparam
```

Where:

*fparam* is the name of a formal parameter with an E, M, or X specifier (memory address).

### Discussion

The `SEGFIX` directive tells the assembler to determine whether a segment override prefix byte is needed to access a given memory location.

See also: Segment override prefix codes, Chapter 6

In the absence of a segment override prefix byte, the processor hardware uses either the DS or SS register, depending on which base register, if any, was used. (E)BP or (E)SP implies SS; every other 32- or 16-bit general register implies DS.

The operand should be a memory address expression. The assembler examines the operand's segment attribute as follows:

- For an operand with a symbolic reference, the assembler determines whether its defining segment has been `ASSUMEd` into the hardware-implied segment register. If so, an override byte is unnecessary and none is generated. If not, the assembler checks the `ASSUMES` of other segment registers looking for the name of the symbol's defining segment. If it is found, the assembler generates the override byte for that segment register; otherwise, the assembler reports an error.

See also: `ASSUME` directive, Chapter 2

- For an operand without a symbolic reference, the assembler checks whether the operand has an explicit segment override. If the override is omitted or is the hardware-implied segment register, the assembler generates no segment override byte. Otherwise, it generates the specified register's override.

## Example

The following codemacro tells the assembler to generate a segment override prefix byte if the operand's defining segment has been `ASSUMEd` into a non-default segment register or is an anonymous reference with an explicit, non-default override.

```
CODEMACRO CMDIV DVSR:EB
    PREFIX67 DVSR
    SEGFIX DVSR
    DB 0F6H
    MODRM 6, DVSR
ENDM
```

## NOSEGFIX Directive

### Syntax

```
NOSEGFIX Sreg, fparam
```

Where:

*Sreg* is one of the segment registers ES, FS, GS, CS, SS, or DS.

*fparam* is the name of a formal parameter with an E, M, or X specifier (memory address).

## Discussion

The `NOSEGFIX` directive tells the assembler to check that an operand's segment attribute matches the specified *Sreg*. Such an operand must either:

- Have an explicit segment override that matches *Sreg*
- Or, have the selector for its defining segment ASSUMED into *Sreg* prior to the codemacro call.

See also: `ASSUME` directive, Chapter 2

The assembler checks that one of these conditions is met but it generates no object code for `NOSEGFIX`. If neither condition is met, the assembler reports an error.

For example, a codemacro for instructions such as `CMPS` should specify `NOSEGFIX ES, fparam` with an E, M, or X specifier for the destination *fparam*. The destination operand of the processor `CMPS`, `INS`, `MOVS`, `SCAS`, and `STOS` instructions must be accessed via the ES segment register.

## WARNING Directive

### Syntax

```
WARNING
```

### Discussion

The `WARNING` directive tells the assembler to flag calls to the codemacro. The assembler issues a warning message at the end of every segment that includes a processor privileged instruction or a call to a codemacro containing the `WARNING` directive.

The assembler generates no object code for the `WARNING` directive.

### Example

This codemacro duplicates the `CLTS` instruction.

```
CODEMACRO CLTS
    WARNING
    DW 0F06H
ENDM
```

## MODRM Directive

### Syntax

```
MODRM fp/num, fparam
```

Where:

*fp/num* is the name of a formal parameter or a number that represents the value that goes into the REG field of the ModRM byte (see Figure 9-2).

*fparam* is the name of another formal parameter with an A, C, E, M, R, S, or X specifier.

### Discussion

The MODRM directive tells the assembler to create the ModRM byte and optional SIB byte, which follow the OPCODE byte(s) in many processor instructions.

See also: SIB and OPCODE instruction encoding bytes, in this chapter

The assembler checks whether the operand is a register, a variable, or an indexed variable and constructs the MOD and R/M fields that correctly represent the operand, together with any displacement that is part of the effective address.

If *fp/num* is a number, that value is used in the ModRM REG field every time the codemacro is called. The number is a continuation of the opcode identifying which instruction the hardware is to execute. If *fp/num* is a formal parameter, the corresponding operand (usually a register) is used each time.

### Examples

1. In the following codemacro, the specifier M indicates that this codemacro matches only when a memory operand is supplied with the call.

```
CODEMACRO FLDENV MEMOP :M
    SEGFIX MEMOP
    DB 11011001B
    MODRM 100B, MEMOP
ENDM
```

- The following codemacro specifies that it adds a memory word into a register. Its `MODRM` directive constructs a `ModRM` byte (see Figure 9-2) from the destination register operand (`REG` field) and a source register or memory operand.

```
CODEMACRO ADD DST:RW, SRC:EW
    PREFIX67 SRC
    PREFIX66 SRC
    SEGFIX SRC
    DB 3
    MODRM DST, SRC
ENDM
```

The following three calls to `ADD` have `DX` encoded as `010B` in bits 5-3 (`REG` field), a `MOD` of `10B` in bits 7-6, and an `R/M` of `000B` in the `ModRM` byte. The comments show the generated object code:

```
ADD DX, [BX] [SI]          ; 00000011 10010000B
    :
ADD DX, MEMWORD[BX] [SI]  ; 00000011 10010000B followed
    ; by offset of MEMWORD (low-order byte first)
    :
ADD DX, [DI]              ; 00000011 10010101B
```

See also: [Dot Operator example](#), in this chapter, for another codemacro with a `MODRM` directive

## Data Initialization Directives

### Syntax

```
DB cmac-expr
DW cmac-expr
DD cmac-expr
```

or

```
DP cmac-expr
```

Where:

*cmac-expr* is an expression (without forward references) that evaluates to a number, a formal parameter name, or a shifted formal parameter with the `DB`, `DW`, and `DD` directives. For the `DP` directive, *cmac-expr* is a formal parameter with a `C` specifier (label expression only).

## Discussion

The codemacro data initialization directives are similar to the DB, DW, DD, and DP storage allocation directives, but they require *cmac-expr* arguments.

For the DB, DW, and DD directives, a number indicates that the same value is to be assembled every time the codemacro is called. A formal parameter indicates that the corresponding operand is to be assembled. A dot record field shift construct indicates that the operand is to be shifted and then plugged in.

For the DP directive, the formal parameter indicates a FAR label in a USE32 segment.

The DBIT, DQ, and DT directives are not allowed inside codemacro definitions.

## Record Initialization Directive

### Syntax

```
rec-name [ <cmac-expr [, ...]> ]
```

Where:

*rec-name* is the name of a previously defined record template.

*cmac-expr* is a number, a formal parameter, a shifted formal parameter or null. A *cmac-expr* list is optional only if *rec-name* was defined with default initial values for its fields; a null list element is valid only if the corresponding field of *rec-name* was initialized.

See also: RECORD directive, Chapter 4

## Discussion

The record initialization directive controls bit fields smaller than 1 byte in codemacro definitions. Use the record template name to initialize bit fields in codemacro definitions; you need not allocate storage for a named variable of the template type.

If an expression value does not fit in the field, the least significant bits are used and no error is reported.

# Using the Dot Operator to Shift Parameters

## Syntax

*fparam.rec-field*

Where:

*fparam* is the name of a formal parameter whose corresponding operand is a number.

*rec-field* is the name of a previously defined record template field.

## Discussion

The shifted formal parameter is a special construct allowed as a DB, DW, or DD operand or as an element of the operand of a record initialization.

The assembler evaluates this expression when the codemacro is called by right-shifting the operand and using the record field's bit offset from the least significant bit as a shift count.

## Example

The dot-shift can be used in a codemacro that duplicates the ESC feature of the instruction set. The opcodes for every floating-point instruction begin with an ESC. ESC opens communication with other devices using the same bus. This enables execution of commands from an external device both with or without an associated operand (address operand only). These commands are represented in ESC as numbers between 0 and 63 inclusive. The external device interprets the number.

```
R53 RECORD RF1:5,RF2:3
R233 RECORD RF6:2,MID3:3,RF7:3
CODEMACRO ESC INDX:DB(0,63),ADDR:E
SEGFIX ADDR
R53 <11011B,INDX.MID3>
MODRM INDX,ADDR
ENDM
```

The R53 line in the body of the codemacro generates 8-bits. The high-order 5-bits are 11011B. The low-order 3-bits are filled with the low-order 3-bits of the operand that corresponds to INDX after it has been shifted right by the shift count of MID3 (bit offset of 3 in R233).

The following example calls the codemacro ESC with an operand (INDX) of 39 on a 16-bit address (ADDR) of MEMWORD, whose offset is 477H from ES, indexed by DI:

```
ESC 39, ES:MEMWORD[DI]
```

The assembler generates the following 5 bytes of object code for this call:

```
0010 0110B ; 26H: the ES override in byte 1
1101 1100B ; INDX = 39 = 0010 0111B
                ; INDX.MID3 =
                ; (000)00100B, so R53<11011B,INDX.MID3>
                ; becomes 11011 100B for [DI],
                ; MOD = 10B,R/M = 101B
1011 1101B ; ModRM byte with fields:
                ; MOD = 10B, OPCODE = 111B
                ; R/M = 101B
0111 0111B ; offset of MEMWORD
0000 0100B ; in these 2 bytes
```

The high-order 5-bits of ESC's first OPCODE byte (see Figure 9-1) are always 11011B. The remaining opcode bits are split between the low-order 3-bits of this OPCODE byte and bits 5-3 of the ModRM byte (see Figure 9-2).

## PROCLen Function

### Syntax

```
PROCLen
```

### Discussion

The PROCLen function returns 00H if the current procedure is type NEAR, and 0FFH if it is type FAR. Code outside of PROC . . ENDP blocks is considered NEAR.

### Example

The RET codemacro uses PROCLen to create the correct machine instructions to return from a call to a NEAR or FAR procedure.

```
R413 RECORD RF:8:4, RF9:1, RF10:3
CODEMACRO RET
    R413 <0CH,PROCLen,3>
ENDM
```

The field RF8 is set to 0CH (1100B), and RF10 is set to 3 (011B). Field RF9, which becomes bit 3 of the allocated record byte, is 0 if the current procedure (in which RET appears) is type NEAR, or it is 1 if the procedure is type FAR. PROCLen returns all 0s or all 1s, but R413 uses only the low-order bit.

# Relative Displacement Directives

## Syntax

RELB *fparam*

RELW *fparam*

or

RELD *fparam*

Where:

*fparam* is the name of a formal parameter with a C (code) specifier letter.

## Discussion

The relative displacement directives instruct the assembler to generate the displacement between the end of an instruction and a label expression operand as follows:

RELB      1-byte displacement

RELW      2-byte displacement

RELD      4-byte displacement

The relative displacement directives may occur elsewhere in a codemacro definition (e.g., a multi-instruction codemacro). However, if a larger formal parameter is matched with a smaller operand, the assembler generates wasted bytes. If a smaller formal parameter is matched with a larger operand, the assembler reports an error.

## Examples

The following codemacros `JMP` and `JE` show the use of relative displacement directives. These codemacros are direct jumps to labels in the current code segment.

1. The following codemacro uses the `RELD` directive. The specifier for the formal parameter calls for a `NEAR` label in the current CS segment. The assembler computes the distance and provides a `dword` to follow the `0E9H` `OPCODE` byte (see Figure 9-1).

```
CODEMACRO JMP PLACE:CDN
    DB 0E9H
    RELD PLACE
ENDM
```

If the target is 513 bytes from the EIP value at the end of the codemacro call, the assembler generates:

```
11101001 00000001 00000010 00000000 00000000B
```

The distance to the target label begins at the end of the `RELD` dword. The first byte counted is that following the 5 bytes comprising this jump. A match occurs only if the target label was assembled under the same assumed CS register as the jump. Object code is generated only if a match occurs.

2. The `JE` codemacro defines a jump that is executed only if `ZF` is 1.

```
CODEMACRO JE PLACE: CW  
    DW 0F84H  
    RELW PLACE  
ENDM
```

If the target is 513 bytes from the IP value at the end of the codemacro call and `ZF` equals 1, the assembler generates:

```
00001111 10000100 00000001 00000010B
```

# Matching Codemacro Calls to Their Definitions

When you call a codemacro, the assembler matches the call to a particular codemacro definition as follows:

## Step 1

The assembler looks for all codemacro definitions with the same name as the call. If the assembler cannot find matching call-definition names, it reports an error.

Then, the assembler evaluates any operands. For a codemacro call with a forward-referenced operand, the assembler reserves space for the definition that would require the most instruction bytes.

If an operand is a register expression without an associated type (e.g., `[EBX]`), or if an implicit reference to the accumulator is made (e.g., `CMDIV`, `MEMVAR`), the other parameters are checked to see if at least one contains an unambiguous modifier type.

Numbers matching B, W, or D, explicitly specified registers, and all variable types suffice to distinguish the modifier type. If no such parameter is found, the assembler reports an error. However, a single, untyped register expression (as in `FSTENV [EBX]`) is allowed.

## Step 2

The assembler searches the chain of codemacro definitions for a match, beginning with the last definition and moving backwards. A match occurs when the number of operands matches the number of formal parameters in a particular definition and each operand matches the corresponding formal in specifier, modifier (if any), and range (if any).

The following is a list of operand-formal matches:

- Specifiers** EAX, AX and AL match A, E, R.  
Labels match C.  
Numbers match D.  
Nonindexed variables match E, M, X.  
Indexed variables and register expressions match E, M.  
Registers (except segment registers) match E, R.  
Segment registers CS, DS, ES, FS, GS and SS match S.  
Floating-point stack elements (ST, ST(0)...ST(7)) match F.  
The floating-point stack top (ST,ST(0)) matches T.
- Modifiers** Modifier-matching is dependent upon the kind of specifier used:
- D** Numbers between -255 and 255 match B only.
  - D** Numbers between -65535 and -255, or +255 and +65535 match W only.
  - D** Numbers between  $-(2^{31} - 1)$  and -65535, or +65535 and  $(2^{31} - 1)$  match D only.
  - D** Other numbers cause an overflow error.
  - C** NEAR labels with the same CS-assume that are -128 to +127 bytes from the end of the codemacro call match only B.
  - C** Other NEAR labels with the same CS-assume match W in USE16 segments or DN in USE32 segments.
  - C** NEAR labels with a different CS-assume match no modifier and cause an error.
  - C** FAR labels match D in USE16 segments and P in USE32 segments.

For all other specifiers:

- Type BIT matches BIT.
- Type BYTE matches B.
- Type WORD matches W.
- Type DWORD matches D.
- Type PWORD matches P.
- Type QWORD matches Q.
- Type TBYTE matches T.

Index register expressions with no associated type (e.g., [(E)BX]) match B, W, or D when used with another operand that has a B, W, or D modifier, respectively. They match no modifier for single-operand instructions and cause an error.

**Ranges** Range specifiers are allowed for parameters that are numbers or registers (specifiers A, D, R, S). If one specifier follows the formal parameter, the value of the operand must match; if two follow the formal, the value must fall within the inclusive range of the specifiers.

For this matching, register operands assume the following numeric values:

| <b>Value</b> | <b>General and Segment Registers</b> |    |    |    |
|--------------|--------------------------------------|----|----|----|
| 0            | EAX                                  | AX | AL | ES |
| 1            | ECX                                  | CX | CL | CS |
| 2            | EDX                                  | DX | DL | SS |
| 3            | EBX                                  | BX | BL | DS |
| 4            | ESP                                  | SP | AH | FS |
| 5            | EBP                                  | BP | CH | GS |
| 6            | ESI                                  | SI | DH |    |
| 7            | EDI                                  | DI | BH |    |

The assembler reports an error if no match can be found for the codemacro call. It pads the generated object code with 90H (NOPs) if a matched definition requires fewer instruction bytes than the assembler reserved for a forward-referenced operand in Step 1.



# Processor Architecture Summary **A**

---

This appendix is a quick reference for assembler application and system programmers. Note that this appendix covers the Intel386 processor. Since there are differences between the Intel386, 376, and Intel486 processors, some of the text in this appendix does not apply to the 376 processor.

See also: Processor architecture, *80386 Programmer's Reference Manual*  
376 processor, Appendix F  
Intel486 processor, Appendix G

This appendix contains four major sections:

- The first section contains illustrations of the formats for the basic data types, and for the general, segment, status, instruction, and control registers.
- The second section summarizes processor memory organization, including effective address computation for assembler operands, and illustrates the data structures that support segmented memory organization.
- The third section illustrates the processor EFLAGS register and describes the individual flags.
- The fourth section summarizes information about processor exceptions and interrupts. It illustrates the IDT (interrupt descriptor table) and the formats for IDT entries (descriptors) and exception error codes.

Application programmers can skip some subsections in this appendix. The following sections are the most useful for application programmers:

- Data Type Formats
- General, Segment, Status and Instruction Registers
- Processor Memory Organization
- Segment Selection and Effective Address Computation
- Processor Flags

# Basic Processor Formats

This section contains reference illustrations for the basic data types and registers used by all assembler programs.

## Data Type Formats

The byte, word, and dword are the fundamental data types. Figure A-1 illustrates their storage format.

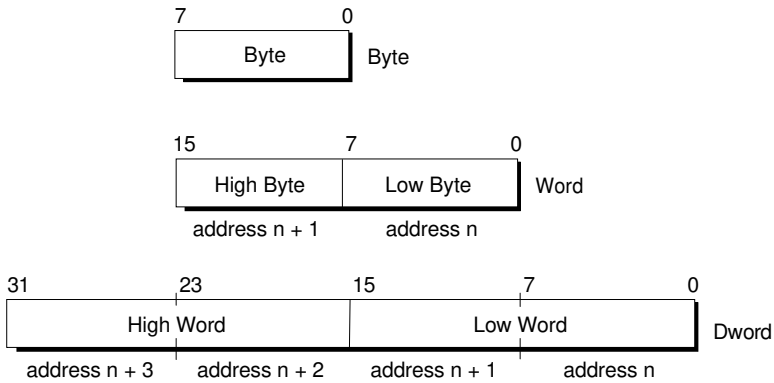

W-3438

**Figure A-1. Fundamental Data Types**

Assembler operands represent interpretations of the fundamental data types. Figure A-2 graphically summarizes the data storage formats supported by the processor.

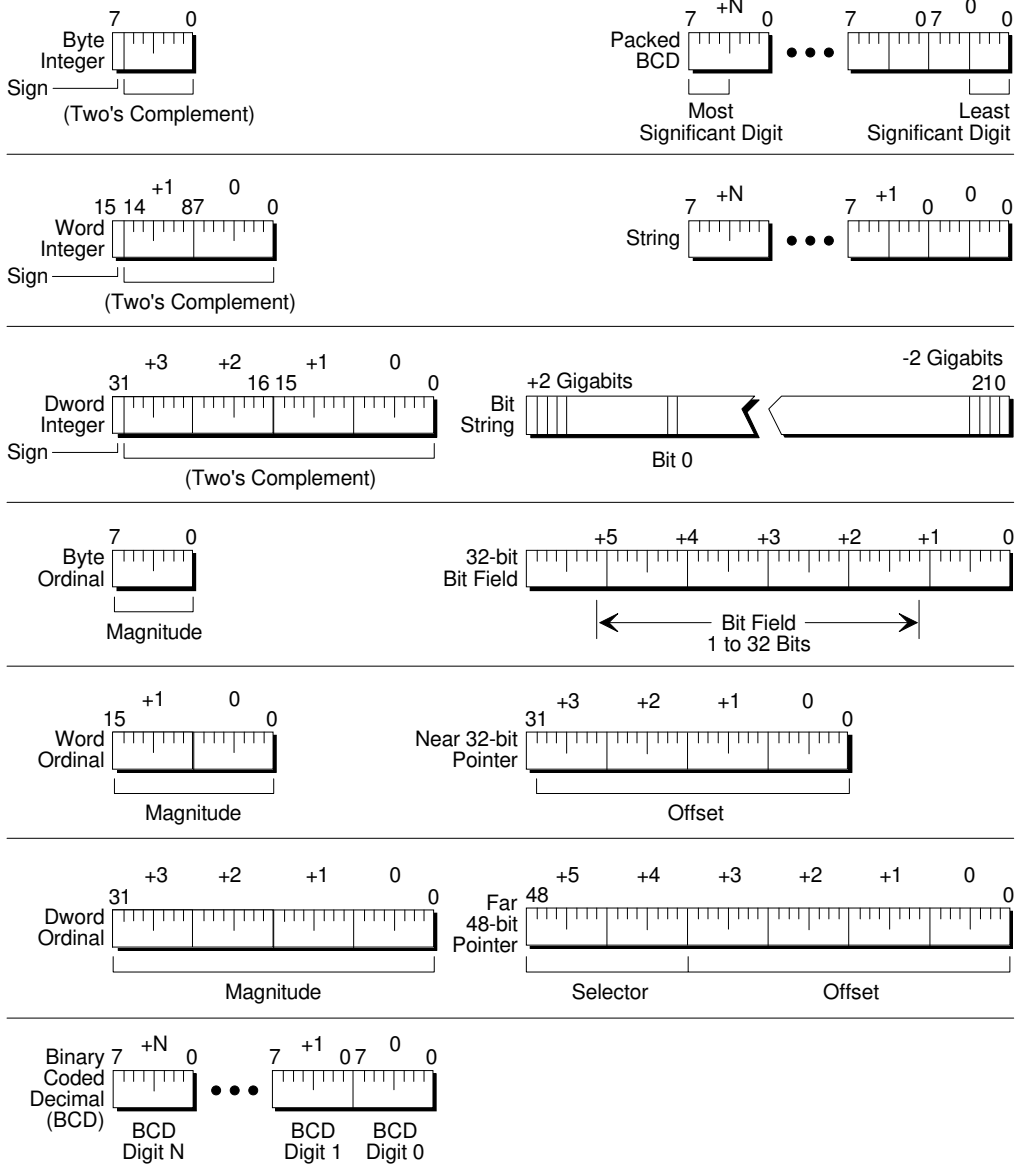

W-3439

**Figure A-2. Processor Data Types and Storage Formats**

Depending on the assembler instruction, the processor data types are one of the following:

**Integer** is a signed numeric value contained in a byte, word, or dword. All operations assume a two's complement representation. The most significant bit of each integer type indicates the sign: 0 for non-negative, 1 for negative. Integer zero is non-negative. The range for each integer type is:

-128..127 for byte integers

-32,768..32,767 for word integers

$-2^{31}..(2^{31} - 1)$  for dword integers

**Ordinal** is an unsigned binary numeric value contained in a byte, word, or dword. The range for each ordinal type is:

0..255 for byte ordinals

0..65,535 for word ordinals

$0..(2^{32} - 1)$  for dword ordinals

**BCD** is a byte (unpacked) representation of an unsigned decimal digit in the range 0..9; the low-order nibble contains the BCD value. Hexadecimal values 0..9 are interpreted as decimal numbers; all other hexadecimal values are invalid. The high-order nibble must be zero for multiplication and division operations.

**Packed BCD**

is a byte representation of 2 decimal digits, each in the range 0..9; values outside this range are invalid. The most significant digit is in the high-order nibble. The range of a packed decimal byte is 0..99.

**String** is a contiguous sequence of bytes, words, or dwords. A string can contain from 1 byte to  $2^{32}$  bytes (4 gigabytes).

**Bit String** is a contiguous sequence of bits. A bit string may begin at any bit position of any byte and contain up to  $2^{32}$  bits.

**Bit Field** is also a contiguous sequence of bits. A bit field may begin at any bit position of any byte, but it can contain only up to 32-bits.

**Near Pointer**

is a 32-bit logical address. It is an offset within a segment. Near pointers are used in either a flat or segmented model of memory organization.

**Far Pointer** is a 48-bit logical address with 2 components: a 16-bit segment selector and a 32-bit offset. Far pointers are used by application programmers only when system designers choose a segmented memory organization.

## **Processor Registers**

The processor registers are classified as general, status and instruction, segment, and system registers. Application programmers need not concern themselves with the system registers.

### **General, Segment, Status and Instruction Registers**

The processor general registers can be used interchangeably to contain the operands of logical and arithmetic operations, and for operands of address computations (except that ESP cannot be used as an index operand). Figure A-3 illustrates the eight 32-bit general registers, the six 16-bit segment registers, and the status and instruction registers.

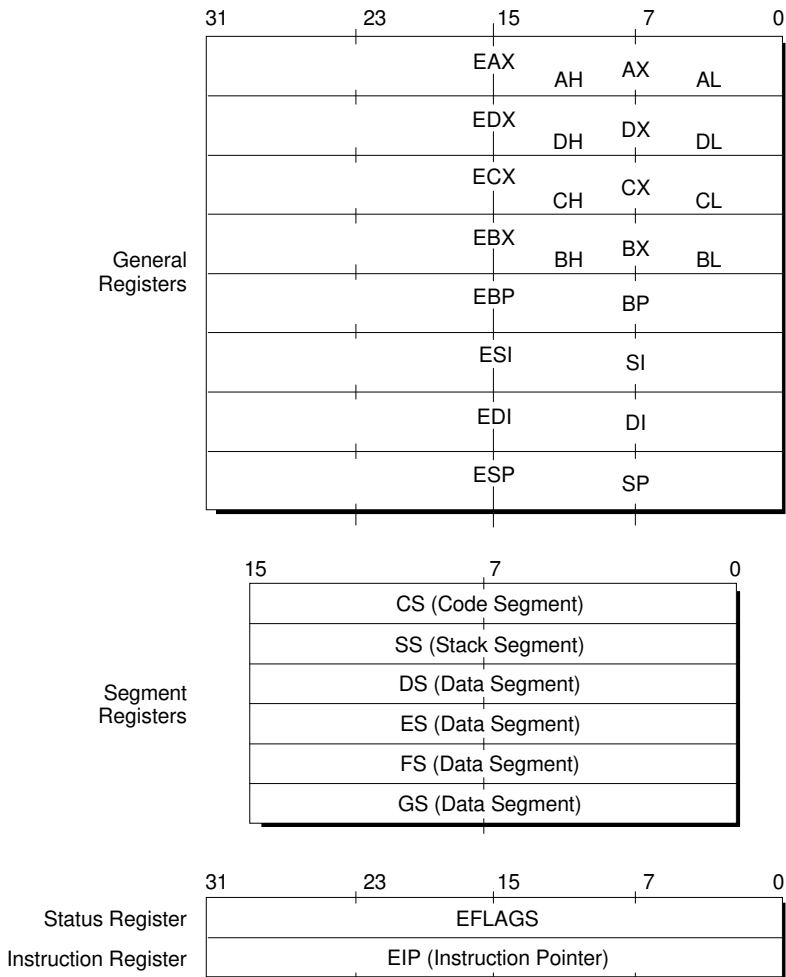

W-3440

**Figure A-3. General, Segment, Status, and Instruction Registers**

The 32-bit general registers are EAX, EDX, ECX, EBX, EBP, ESI, EDI, and ESP.

As Figure A-3 shows, the low-order word of each general register represents a word register; each has a distinct name without the E prefix. Each word register can be used as an operand to contain 16-bit data items. The AX, DX, CX, and BX word registers contain separately named byte registers to contain 8-bit data items. AH/L, DH/L, CH/L, and BH/L can be used as operands in some assembler instructions.

The segment registers identify up to six segments that are immediately accessible to an executing program. The CS register addresses the currently executing code segment. SS addresses the current stack segment. DS, ES, FS, and GS access data segments; DS is the default data segment register (see Table A-1).

Application programmers can ignore the segment registers - and the instructions that deal with them - if their operating system uses an unsegmented memory model. If it doesn't, the 16-bits shown in Figure A-3 represent a selector. Each segment register also has a cache that holds the descriptor associated with each selector that is loaded into a segment register.

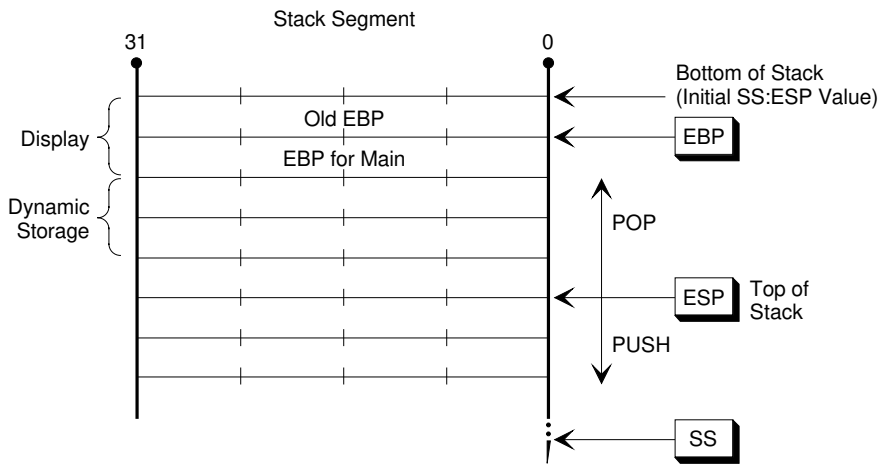

W-3441

**Figure A-4. Processor Stack with Stack Frame**

The EIP register contains the offset address, relative to the start of the current code segment, for the next instruction to be executed in sequence.

As in the general registers, the low-order word of the EFLAGS register represents a 16-bit register: the FLAGS register.

See also: (E) FLAGS, in this appendix

Note that assembler instructions that use the stack depend on the SS, EBP, and ESP registers. Figure A-4 illustrates the processor stack.

SS addresses the single stack in memory that is directly accessible from the currently executing code segment.

EBP is the stack frame base pointer, identifying the base address of the current stack frame. When EBP is used as the base register in an offset calculation, the processor calculates the current offset, relative to SS, automatically.

ESP points to the current top of the stack. It is referenced implicitly by the `PUSH`, `POP`, `CALL`, `RET`, `INT`, and `IRET` instructions.

## System Registers

System control, global descriptor table (GDTR), local descriptor table (LDTR), interrupt descriptor table (IDTR), test (TR), and debug registers are accessible only to system programmers via variants of the `MOV` instruction.

Figure A-5 illustrates the system control registers.

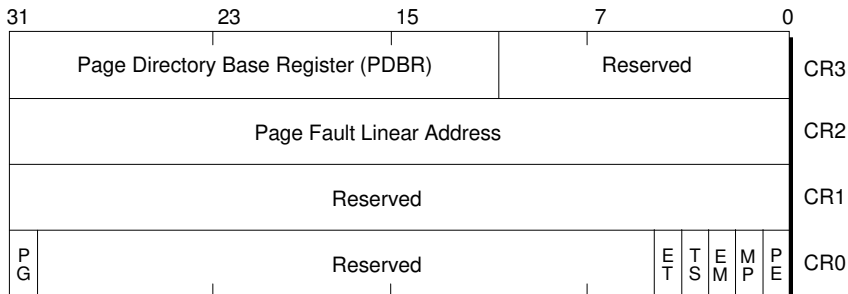

W-3442

**Figure A-5. System Control Registers**

The CR0 register contains the following system control flags:

- PE** (bit 0) is the Protection Enable control flag. Setting PE causes the processor to execute in protected mode. Clearing PE causes the processor to execute in real address mode.
- MP** (bit 1) is the Monitor coProcessor control flag. When MP is set, the processor tests the TS (task switch) flag at every occurrence of a `WAIT` instruction; it signals Exception 7 (math unit unavailable) if the floating-point coprocessor is currently executing a floating-point instruction. If MP is clear, a floating-point coprocessor is not attached to the processor.
- EM** (bit 2) is the EMulation control flag. When EM is set, the occurrence of an `ESC` (floating-point) instruction raises Exception 7 so the processor can transfer control from the currently executing program to an exception handler for floating-point emulation.
- TS** (bit 4) is the Task Switch control flag. The processor sets TS with every task switch.
- ET** (bit 4) is the Extension Type control flag. If ET is set, the processor uses the 32-bit protocol of an Intel387 coprocessor; if ET is clear, the processor uses the 16-bit protocol of an Intel287 coprocessor.
- PG** (bit 31) is the PaGing control flag. If PG is set, the processor handles a paged memory organization. The processor translates logical segment addresses into linear addresses, maps the linear addresses through a page directory and page table, and accesses physical addresses in a page frame.

The CR2 register is used for handling page faults when PG is set. The processor stores the linear address that triggers the page fault into CR2.

The CR3 register is also used when PG is set. CR3 stores the base address of the page table directory for the current task.

The CR0 flags apply to the system as a whole. The `EFLAGS` register contains additional system flags that control the interaction among system software components.

The GDTR, LDTR, IDTR, and TR registers locate the data structures that control segmented memory management. See the Processor Memory Organization and Processor Exceptions and Interrupts subsections for the formats these registers handle.

See also: Debug and test registers, *80386 Programmer's Reference Manual*

# Processor Memory Organization

The physical memory of the processor is organized as a sequence of bytes. Each byte in a processor segment has a unique address in the range  $0..2^{32} - 1$  (4 gigabytes). Assembler programs are independent of the physical address space.

System designers determine the model of memory organization seen by application programmers. The processor architecture gives system designers the freedom to choose a model for each task.

The choice of models varies between the following extremes:

- A flat address space maps the logical addresses of an assembler program 1-to-1 to the physical address space as elements of a single array. A pointer to this flat address space is a 32-bit ordinal number in the range  $0..2^{32} - 1$ .
- A segmented address space consists of a collection of up to 16,383 linear address spaces, each up to 4 gigabytes in length. Each segment is a sequence of contiguous byte addresses. A pointer in a segmented address space consists of two parts:
  - A 16-bit segment selector that identifies a segment.
  - A 32-bit offset that is an ordinal index to a byte within a segment.

Assembler programs implicitly use a segmented logical address space; the CS, SS, DS, ES, FS, and GS segment registers contain selectors to the program's code, data, and stack segments. Figure A-6 illustrates this implicit model.

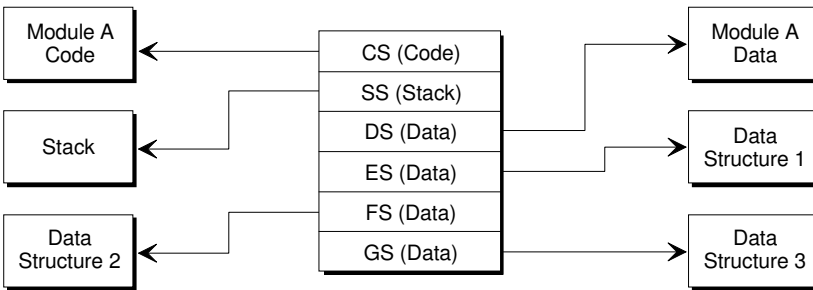

W-3443

**Figure A-6. Memory Segmentation Model for ASM386 Programs**

For an assembler application programmer, it is immaterial how this model is mapped to the processor physical address space.

## Segment Selection and Effective Address Computation

If system designers have chosen a flat model of memory organization, the segment registers point to the same segment and the processor rules for choosing them are hidden from application programmers. Nevertheless, the rules remain in effect.

For other models of memory organization, there is a close connection between the kinds of memory reference made in an assembler program and the segments in which instructions and operands reside.

Table A-1 summarizes the processor default segment register selection rules.

**Table A-1. Default Segment Register Selection Rules**

| <b>ASM386 Segment Type</b> | <b>Memory Reference Needed</b> | <b>Segment Register Used</b> | <b>Processor Implicit Segment Selection</b>                                             |
|----------------------------|--------------------------------|------------------------------|-----------------------------------------------------------------------------------------|
| Code                       | Instruction                    | CS                           | Automatic with instruction prefetch.                                                    |
| Stack                      | Stack                          | SS                           | All stack pushes and pops; any memory reference that uses ESP or EBP as a base pointer. |
| Data                       | Local Data                     | DS                           | All data references except relative to stack or string destination.                     |
|                            | Strings                        | ES                           | Destination of string instructions.                                                     |

Most assembler instructions allow programmers to use a segment override prefix to specify an explicit segment register selection. However, a segment override prefix cannot alter the segment selection rules in the following three cases:

- ES must be used for destination strings with the string instructions.
- SS must be used for stack instructions.
- CS must be used for instruction fetches.

The CS, SS, DS, ES, FS, and GS segment registers contain a selector to a logical segment address. Every assembler instruction accesses the logical addresses of code, stack, and data indirectly through a segment register. For instructions encoded with a ModRM byte, the offset within a segment is calculated by taking the sum of up to three components:

- A displacement element in the instruction
- A base register
- An index register, which can be automatically multiplied by a scaling factor of 1, 2, 4, or 8

Figure A-7 illustrates this address calculation.

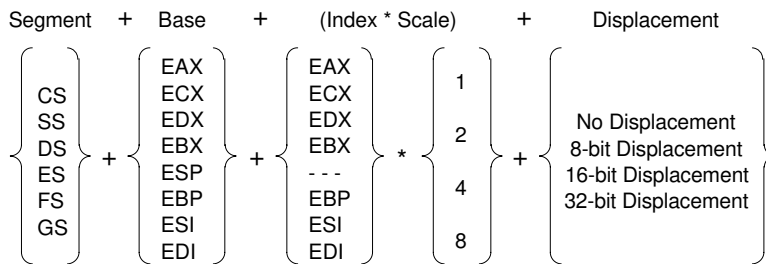

W-3444

**Figure A-7. Effective Address Calculation**

The segment offset that results from adding these components to the segment register address is called an effective address:

- The Base and Index components both use the same general registers to address dynamically allocated data, such as procedure parameters and local variables in the stack, or the beginning of one record in an array of records.
- The Scaling Factor allows efficient indexing into an array when its elements are 2, 4, or 8 bytes wide.
- The Displacement component is encoded in the instruction; it is used for addressing fixed data, such as the location of a simple scalar operand. The displacement alone indicates the offset of an operand. An 8-, 16-, or 32-bit displacement can be used.

## Segmented Memory Management

The processor transforms logical addresses (i.e., addresses as viewed by assembler programmers) into physical addresses in one or two steps:

1. Segment translation, in which a logical address consisting of a segment selector and segment offset are converted to a linear address. The linear address can be mapped directly to a physical address if system designers choose not to implement paging.
2. Page translation, in which a linear address is converted to a physical address if system designers choose a paged memory model.

Figure A-8 sketches the segment and optional page translation of logical addresses to physical addresses.

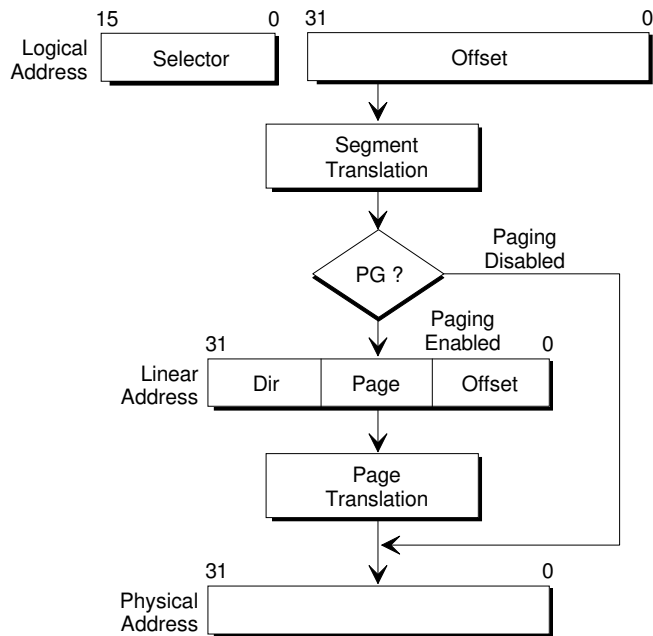

W-3445

**Figure A-8. Processor Address Translation Overview**

The processor uses the following data structures and registers to translate a logical address into a linear address:

- Descriptors
- Segment registers (see Figure A-3)
- GDT (global descriptor table) and LDT (local descriptor table) registers
- Selectors

In a paged memory system, the processor also uses the control register CR3 illustrated in Figure A-5.

Figure A-9 illustrates segment to linear address translation, together with linear to physical address translation in a paged system, in more detail.

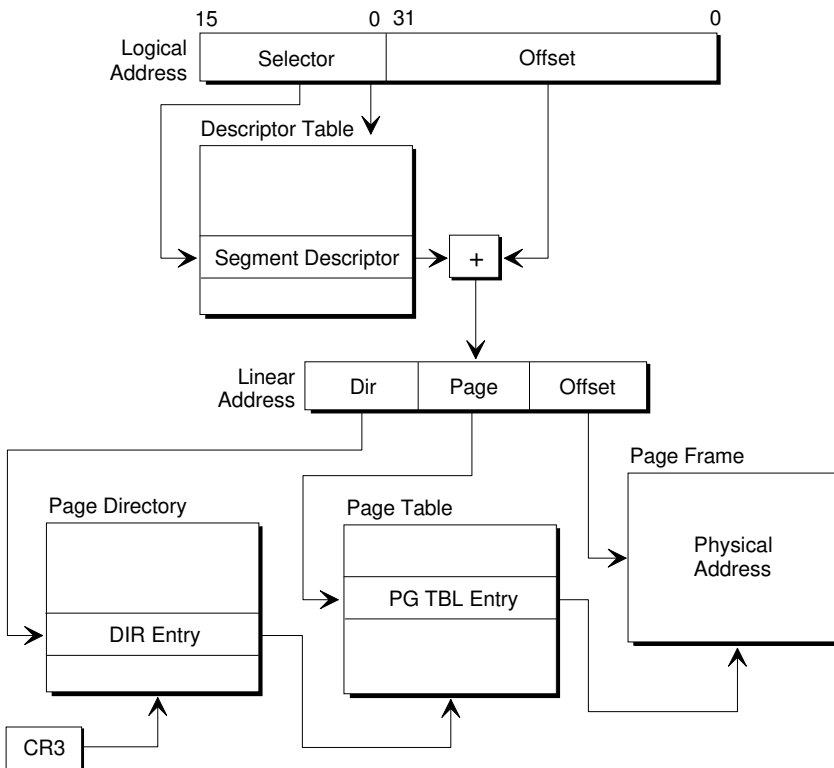

W-3446

**Figure A-9. Segment Address Translation in a Paged System**

# Segment Descriptors

The processor uses a descriptor in a segment register's cache to map a logical address to a linear address. In addition, descriptors contain protection parameter fields that apply to segment translation. The protection field values determine how the processor does the following:

- Type checking
- Limit checking
- Restriction of addressable domain
- Restriction of procedure entry points
- Restriction of the assembler instruction set

Figure A-10 illustrates the general segment descriptor formats for application and system segments.

Creation and maintenance of descriptors is the responsibility of system software.

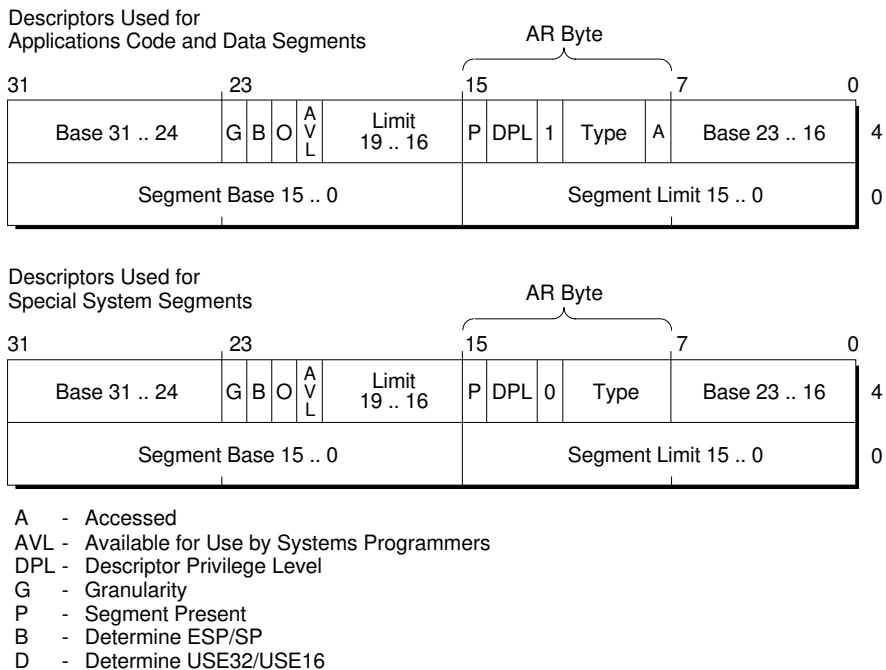

W-3447

**Figure A-10. General Segment Descriptor Formats**

## Descriptor Address Translation Fields

Both application and system segment descriptors contain the following address translation fields:

- Base** (32-bits) defines the location of a segment within a 4-gigabyte linear address space.
- Limit** (20-bits) defines the size of the segment. Depending on the setting of the Granularity bit (23), the processor interprets the limit field as units of 1 byte ( $G = 0$ ) or units of 4 Kilobytes ( $G = 1$ ).

## Descriptor Access Rights (AR)

Bits 8-15 of the upper dword in Figure A-10 is the descriptor AR (access rights) byte. The processor checks the protection parameters in this byte during segment translation.

These fields in a descriptor's high-address dword are:

- Accessed** (bit 8) is set when the selector for this segment is loaded into a segment register or used by a selector test instruction.
- Type** (bits 9-12) specifies the intended usage of a segment. Its value indicates executable/readable code and readable/writable data segments, or it indicates a system descriptor type, such as a call gate, task gate, task state segment (TSS), interrupt gate, etc.
- DPL** (bits 13-14) specifies the Descriptor Privilege Level; this field's value determines whether the segment can be accessed from other code or system segments in a protected system.
- Present** (bit 15) is set if this descriptor is valid for use in address formation. If  $P = 0$ , the processor raises an #NP exception when a selector for this descriptor is loaded into a segment register.

For assembler instructions that transfer control among code segments, the processor checks the validity of a descriptor's AR fields before calculating the segment linear address — or allowing access to a segment. System designers determine the restrictions enforced by the processor in the descriptors created by compilers, linkers, loaders, and by the operating system itself.

## Descriptor Tables and Selector Format

Segment descriptors are stored in memory as tables: arrays of 8-byte elements. The processor global descriptor table (GDT) is an array of descriptors for up to 8192 segments, local descriptor tables (LDT), tasks, and/or gates. The first entry of the GDT (selector INDEX = 0) is not used by the processor. The processor locates the GDT and the current LDT in memory by means of the GDTR and LDTR registers. These registers store the memory base addresses of these tables, together with the segment limits.

The selector portion of any logical address identifies a descriptor. A selector specifies the global or a local descriptor table and indexes a descriptor in that table. Figure A-11 illustrates the format of a selector.



TI - Table Indicator  
RPL - Requestor's Privilege Level

W-3448

**Figure A-11. Selector Format**

Segment selectors contain the following fields:

- RPL** (bits 0-2) is the Requesting Privilege Level field. This represents the privilege level of a code segment, such as a procedure, that may request access to a data segment or a control transfer. For example, an application routine might call an operating system I/O routine if system designers decide to prohibit application from using the `IN` and `OUT` instructions.
- TI** (bit 3) is the Table Indicator bit. It specifies whether the selector refers to the GDT (TI = 0) or to the current LDT (TI = 1).
- Index** (bits 4-15) selects one of up to 8192 descriptors in the GDT or current LDT. The processor multiplies the index of the selector by 8 (length in bytes of a descriptor), and adds the result to the base address of the selected descriptor table.

See also: `IOPL` field, in the Processor Flags section of this appendix

The processor segment registers (see Figure A-3) contain the selectors to current segments; each segment register also has an inaccessible cache that holds the descriptor associated with the selector. CS contains the selector and descriptor for the currently executing code segment, SS the selector and descriptor for the current stack, etc.

## **Processor Protection, Gate Descriptors, and Task Switches**

All processor descriptors store protection parameters in their access rights (AR) fields. These parameters can be ignored at the discretion of system designers. Or, they can be exploited to verify memory accesses and instruction execution, to detect and identify bugs, and to restrict damage by runaway applications.

## Protection and Privilege Levels

Both application and system segment descriptors and selectors are designed for protected systems. Central to processor protection checking is the notion of privilege levels. By assigning values from 0 to 3 (highest to lowest privilege) to the descriptors and selectors visible to the processor, system designers use the processor to protect modules within the operating system. For example, Figure A-12 illustrates how the processor makes a privilege check for data access.

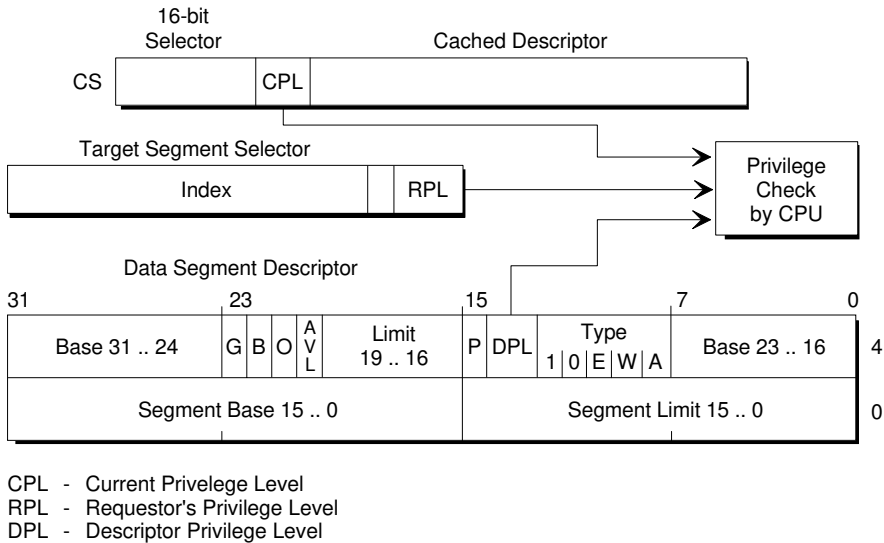

W-3449

**Figure A-12. Processor Privilege Check for Data Access**

As Figure A-12 shows, three different privilege levels enter into this type of processor protection check:

1. The segment selector in the CS register contains a protection field (CPL) that specifies the current privilege level.
2. The selector attempting to access a data segment contains the RPL field (requesting privilege level).
3. The descriptor of the target data segment's DPL field is also a protection field.

The currently executing code segment can access this data only if the DPL of the target segment is numerically greater (less privileged) or equal to the maximum of the CPL and the RPL.

Level 0 is the highest privilege level. If CPL equals 0, the currently executing code segment can access any data segment in the system. (The IOPL field in the processor flags register is a fourth privilege level that is checked for assembler instructions that perform I/O.

See also: IOPL field, in the Processor Flags section of this appendix

## Protected Control Transfers Use Gate Descriptors

The processor uses gate descriptors to provide protection for control transfers among executable segments at different privilege levels, possibly in a multi-tasking system. There are 4 kinds of gate descriptors:

- Call gates
- Task gates
- Trap gates
- Interrupt gates

Call gate and task gate descriptors are stored either in the GDT or in an LDT. Note that call and task gate descriptor access can be restricted either by using the protection fields in these descriptors or by restricting access to the LDT in which they are stored.

Task gate descriptors are used in a multi-tasking processor system. Trap and interrupt gates transfer control to an exception handler; they are stored in the IDT (interrupt descriptor table).

See also: Processor Exceptions and Interrupts, in this appendix

## Call Gate Descriptor Format

Figure A-13 illustrates the format of a call gate descriptor.

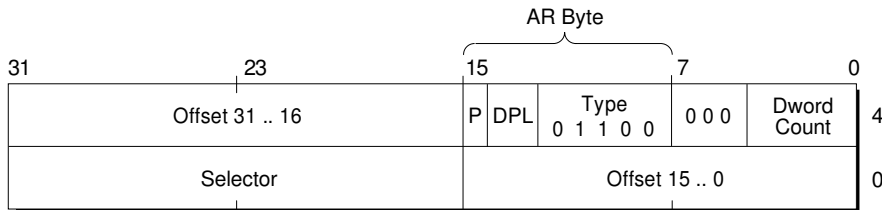

W-3450

**Figure A-13. Call Gate Descriptor Format**

A processor call gate:

- Defines an entry point of a procedure
- Specifies the privilege level of such an entry point

The selector and offset fields of a call gate descriptor form a pointer to the entry point of a procedure. In a control transfer that accesses a call gate, only the selector part of a far pointer operand is used; the far pointer's offset part isn't needed to access the call gate descriptor.

## Task Gate, TSS Descriptor, and TSS Format

Figure A-14 illustrates a task gate descriptor.

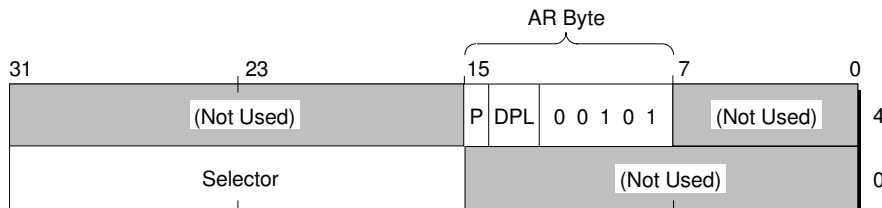

W-3451

**Figure A-14. Task Gate Descriptor Format**



Figure A-16 shows the format of a processor TSS. Note that a processor TSS is not identical to an 286 processor TSS.

|                                 |    |                           |   |     |     |
|---------------------------------|----|---------------------------|---|-----|-----|
| 31                              | 23 | 15                        | 7 | 0   |     |
| I/O Map Base                    |    | 0 0 0 0 0 0               |   | 0 0 | 0 0 |
|                                 |    |                           |   | 0 0 | 0 0 |
|                                 |    |                           |   | 0 0 | T   |
|                                 |    |                           |   |     | 64  |
| 0 0 0 0 0 0 0 0 0 0 0 0 0 0 0 0 |    | LDT                       |   |     |     |
|                                 |    |                           |   |     | 60  |
| 0 0 0 0 0 0 0 0 0 0 0 0 0 0 0 0 |    | GS                        |   |     |     |
|                                 |    |                           |   |     | 5C  |
| 0 0 0 0 0 0 0 0 0 0 0 0 0 0 0 0 |    | FS                        |   |     |     |
|                                 |    |                           |   |     | 58  |
| 0 0 0 0 0 0 0 0 0 0 0 0 0 0 0 0 |    | DS                        |   |     |     |
|                                 |    |                           |   |     | 54  |
| 0 0 0 0 0 0 0 0 0 0 0 0 0 0 0 0 |    | SS                        |   |     |     |
|                                 |    |                           |   |     | 50  |
| 0 0 0 0 0 0 0 0 0 0 0 0 0 0 0 0 |    | CS                        |   |     |     |
|                                 |    |                           |   |     | 4C  |
| 0 0 0 0 0 0 0 0 0 0 0 0 0 0 0 0 |    | ES                        |   |     |     |
|                                 |    |                           |   |     | 48  |
| EDI                             |    |                           |   |     | 44  |
| ESI                             |    |                           |   |     | 40  |
| EBP                             |    |                           |   |     | 3C  |
| ESP                             |    |                           |   |     | 38  |
| EBX                             |    |                           |   |     | 34  |
| EDX                             |    |                           |   |     | 30  |
| ECX                             |    |                           |   |     | 2C  |
| EAX                             |    |                           |   |     | 28  |
| EFLAGS                          |    |                           |   |     | 24  |
| Instruction Pointer (EIP)       |    |                           |   |     | 20  |
| CR3 (PDPR)                      |    |                           |   |     | 1C  |
| 0 0 0 0 0 0 0 0 0 0 0 0 0 0 0 0 |    | SS2                       |   |     |     |
|                                 |    |                           |   |     | 18  |
| ESP2                            |    |                           |   |     | 14  |
| 0 0 0 0 0 0 0 0 0 0 0 0 0 0 0 0 |    | SS1                       |   |     |     |
|                                 |    |                           |   |     | 10  |
| ESP1                            |    |                           |   |     | 0C  |
| 0 0 0 0 0 0 0 0 0 0 0 0 0 0 0 0 |    | SS0                       |   |     |     |
|                                 |    |                           |   |     | 8   |
| ESP0                            |    |                           |   |     | 4   |
| 0 0 0 0 0 0 0 0 0 0 0 0 0 0 0 0 |    | Back Link to Previous TSS |   |     |     |
|                                 |    |                           |   |     | 0   |

Note: 0 means Intel reserved. Do not define.

W-3453

**Figure A-16. General Segment Descriptor Formats**

The fields of a TSS are either dynamic or static:

1. The processor updates the following fields with each switch from the task:
  - Segment registers GS, FS, DS, SS, CS, and ES
  - General registers EDI, ESI, EBP, ESP, EBX, EDX, ECX, and EAX
  - Flags register EFLAGS
  - Instruction pointer EIP
  - Back link selector to previously executing TSS (updated only when a return is expected)
2. The processor reads but does not change the following fields:
  - T-bit (debug trap bit); if set, the T-bit causes the processor to raise a debug exception when a task switch occurs
  - I/O map base address (see Figure A-17)
  - Selector of the task's LDT
  - CR3 (PDBR) register that contains the base address of the task's page directory (read only if paging enabled)
  - SS2, ESP2, SS1, ESP1, SSO, and ESPO pointers to the stacks for privilege levels 0..2

## **I/O Permission Bit Map**

The I/O map base address stored in a TSS contains an offset to the beginning of the (memory) I/O permission bit map for the TSS. Figure A-17 illustrates the I/O address bit map and permission bit map.

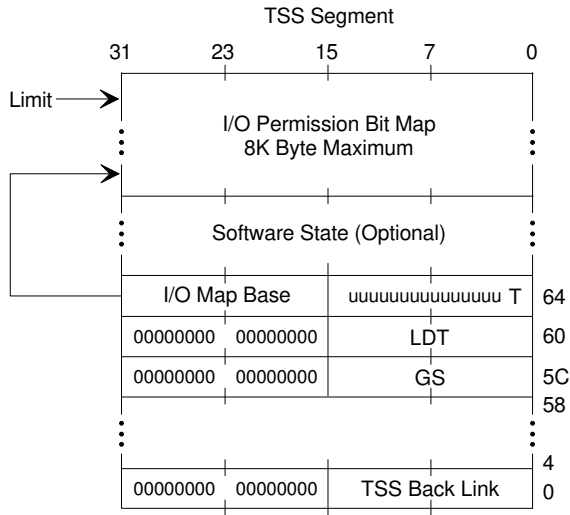

W-3454

**Figure A-17. I/O Address Bit Map**

Each bit in the map corresponds to an I/O port address. The I/O permission bit map allows the processor to selectively trap references to specific I/O port addresses. In protected mode, `IN`, `INS`, `OUT`, and `OUTS` instructions are subject to two protection checks:

1. The processor checks that the instruction's CPL (current privilege level) is less than or equal to the value of `IOPL` in the `EFLAGS` register. `IOPL` is the lowest privilege level at which direct I/O can be performed. (0 is the highest privilege level and 3 is the lowest privilege level.)
2. If the current privilege level is insufficient, the processor checks the I/O permission bit map. Each bit in the map corresponds to an I/O port byte address. The processor tests 4 bits for a dword I/O operation, 2 bits for a word I/O operation, etc. If any tested bit is set, the processor signals a `#GP` exception.

Because the I/O permission bit map is in a TSS segment, different tasks can have different maps; a multi-tasking operating system can allocate I/O ports on a task-by-task basis by changing the I/O permission map.

# Processor Flags

This appendix section describes the processor flags. Figure A-18 illustrates the format of the `EFLAGS` register.

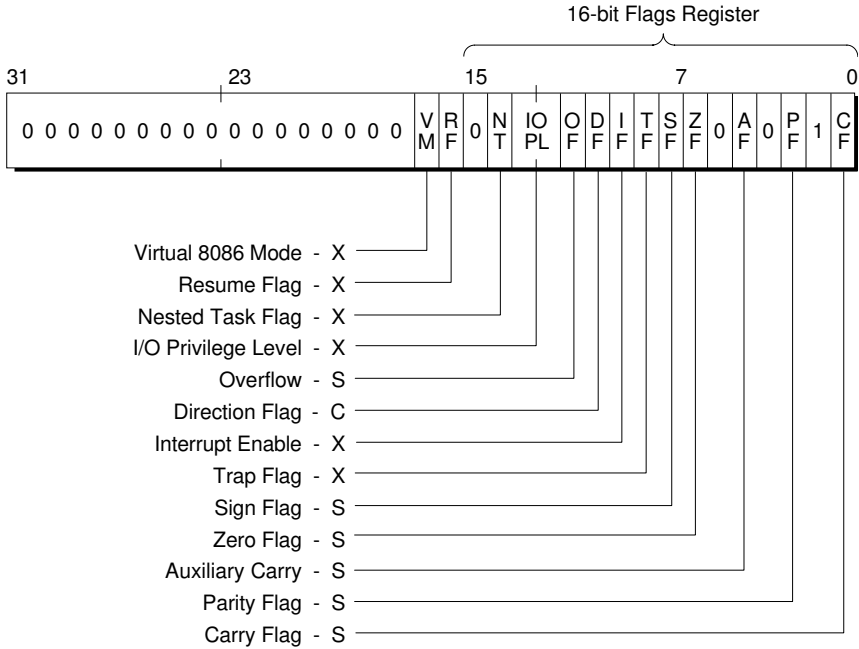

S = Status Flag    C = Control Flag    X = System Flag

Note: 0 or 1 indicates Intel reserved. Do not define.

W-3455

**Figure A-18. Processor EFLAGS Register**

Flag conditions reflect the result of a mathematical operation, the state of operation of the processor, or the current restrictions placed upon the microprocessor's operation. There are two categories of flags in the processor `EFLAGS` register:

- The carry, parity, auxiliary, zero, sign, and overflow flags are status flags.
- The direction flag is a control flag; the interrupt, trap, nested task, resume, and virtual mode flags are system control flags.

The IOPL field of EFLAGS specifies the system Input/Output Privilege Level. Tasks with less privilege (a higher numerical value) than IOPL cannot perform I/O operations unless the I/O address bit(s) allow access to an I/O port

See also: I/O Permission Bit Map, In this appendix

The following sections briefly explain the function of each flag and give a general description of how they are affected by processor instructions. To find out how (or if) a particular instruction affects the flags, see the instruction's reference page.

See also: Instruction reference pages, Chapter 6

## Status Flags

The status flags indicate the results of most assembler arithmetic, logical, or comparison operations. Figure A-19 illustrates the status flags.

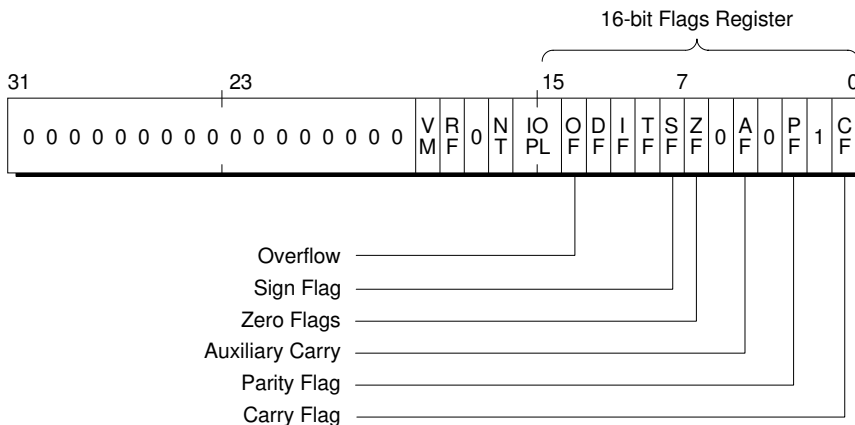

W-3456

**Figure A-19. Status Flags Format**

The six status flags are set (to 1) or cleared (to 0) by most arithmetic operations to reflect certain properties of the result:

- CF** (bit 0) is set if the operation resulted in a carry out of (from addition) or a borrow into (from subtraction) the high-order bit of the result; otherwise, CF is cleared.
- PF** (bit 2) is set if the modulo 2 sum of the low-order 8 bits of the result is 0 (even parity); otherwise, PF is cleared (odd parity).

- AF** (bit 4) is set if the operation resulted in a carry out of (from addition) or borrow into (from subtraction) the low-order 4 bits of the result; otherwise, AF is cleared. AF is set according to the carry/borrow out of bit 3. It is not affected by the size of the operand.
- ZF** (bit 6) is set if the result of the operation is 0; otherwise, ZF is cleared.
- SF** (bit 7) is set if the result of the operation is negative; otherwise, SF is cleared.
- OF** (bit 11) is set if the signed operation resulted in an overflow; otherwise, OF is cleared.

A program can test the setting of the carry, parity, zero, sign, and/or overflow flags in order to transfer control according to the outcome of a previous operation. See Table 6-8 for a list of instructions that assign definitive values to one or more status flags.

It is important to know which flags are set by a particular instruction. For example, assume a program is to test the parity of an input byte and execute one instruction sequence if parity is even and another if parity is odd. Coding `JPE` (jump if parity is even) or `JPO` (jump if parity is odd) immediately following the `IN` (input) instruction would cause random jumps because `IN` does not affect the parity flag. It is necessary to code an instruction that alters the parity flag (such as an `ADD` of 0) between the `IN` instruction and the conditional jump instruction to get meaningful results in such a program.

## Carry Flag

As its name implies, the carry flag is used to indicate whether an addition causes a carry into the next higher-order digit. (However, `INC` and `DEC` do not affect CF.) The carry flag is also used as a borrow flag in subtractions.

For example, the addition of two 1-byte numbers can produce a carry out of the high-order bit:

| <b>Hex Value</b> | <b>Bit Number:</b> |             |                   |
|------------------|--------------------|-------------|-------------------|
|                  | <b>7654</b>        | <b>3210</b> |                   |
| AEH              | 1010               | 1110B       |                   |
| +74H             | 0111               | 0100B       |                   |
| 122H             | 0010               | 0010B       | ; = 22H           |
|                  |                    |             | ; carry flag = 1. |

An addition that causes a carry out of the high-order bit of the destination sets the flag to 1; an addition that does not cause a carry resets the flag to 0.

The logical `AND`, `OR`, and `XOR` instructions also affect `CF`. These instructions set or reset particular bits of their destination (register or memory).

See also: Logic instructions, Chapter 6

The rotate and shift instructions move the contents of the operand (registers or memory) one or more positions to the left or right. `RCL` and `RCR` treat the carry flag as though it were an extra bit of the operand. `ROL` and `ROR` assign an operand bit to `CF`. The bit test instructions copy a specified bit into `CF`.

## Parity Flag

Parity is determined by counting the number of 1 bits in the low-order 8 bits of the destination of the last operation to affect `PF`. Instructions that affect the parity flag set the flag to 1 for even parity and reset the flag to 0 for odd parity.

## Auxiliary Carry Flag

The auxiliary carry flag indicates a carry out of bit 3 of the result. This flag cannot be tested directly in an assembler program. `AF` allows the decimal adjust instructions to perform their function; it represents a carry out of or borrow into the least significant 4-bit digit when performing BCD arithmetic. The auxiliary carry flag is affected by all add, subtract, increment, decrement, compare, and the logical `AND`, `OR`, and `XOR` instructions.

## Zero Flag

Many assembler instructions affect the zero flag. `ZF = 1` indicates that the last operation to affect `ZF` resulted in all 0s in the destination (register or memory). If the result was something other than 0, `ZF` is reset to 0. A result that has a carry and a 0 result sets both flags, as shown:

```
10100111
+01011001
-----
00000000 ; carry flag = 1
           ; zero flag = 1
```

## Sign Flag

The most significant bit of the result of operations on registers or memory can be interpreted as a sign. Instructions that affect the sign flag set the flag equal to this bit. A 0 indicates a non-negative value; a 1 indicates a negative value. This value is duplicated in the sign flag so that conditional jump instructions can test for positive and negative values.

## Overflow Flag

The overflow flag is set if a signed operation resulted in a carry into the most significant bit of the result, but not a carry out of this bit or vice versa. Otherwise, OF is cleared.

## Control and System Control Flags

The control and system flags determine how certain processor instructions behave and are tested during processor protection checking. Figure A-20 illustrates the control and system control flags.

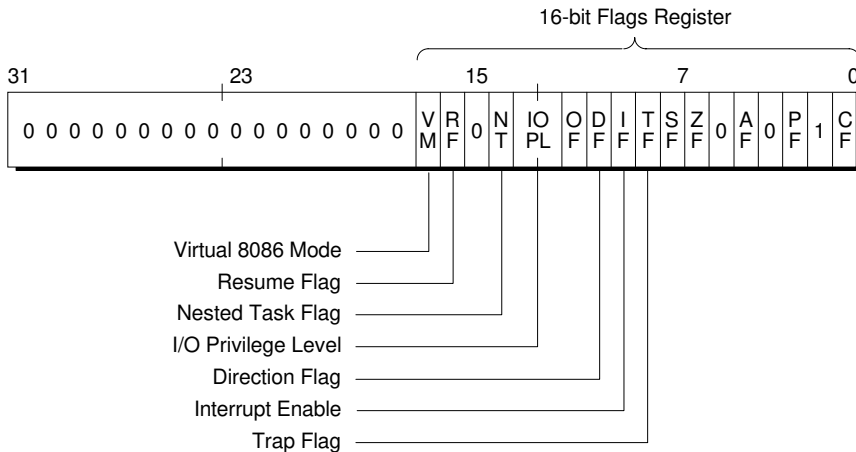

W-3457

**Figure A-20. Control Flags and IOPL Format**

The following flags can be set/cleared by explicit processor instructions:

**IF** (bit 9) is the Interrupt Flag, used to enable or disable certain kinds of external interrupts. For example, if IF is set, vectored and external interrupts are enabled. The instructions STI and CLI set and clear IF, respectively. IF is a system control flag. In protected mode, CLI and STI can be executed only if the CPL is less than or equal to IOPL (the current privilege level has at least as much privilege as the I/O privilege level).

**DF** (bit 10) is the Direction Flag, used by string instructions to determine whether to increment or decrement the default string registers (E)SI and (E)DI during a string operation. The instructions `STD` and `CLD` set and clear DF, respectively. If DF is set, (E)SI and (E)DI are decremented; if DF is cleared, (E)SI and (E)DI are incremented.

The `EFLAGS` register contains other system control flags and the `IOPL` field:

**TF** (bit 8) is the Trap Flag. It controls the generation of single-step interrupts. Once TF is set, an internal single-step interrupt will occur after each instruction is executed.

**VM** (bit 11) is the Virtual Mode flag. When set, it tells the processor to switch from protected mode to virtual 8086 mode. The VM flag can be set by task switches that occur during protected mode execution, or by the `IRET` instruction (only at `CPL = 0`). `PUSHF` always clears VM, even if the processor is executing in virtual 8086 mode; `POPF` has no effect on VM. However, an `EFLAGS` image pushed during interrupt processing or saved during a task switch will contain a 1 in VM if the interrupted process was executing in virtual 8086 mode.

**NT** (bit 14) is the Nested Task flag. It is set to indicate that an executing task is nested within another task. The NT flag is set or reset by control transfers through interrupt, trap, and task gates. The `IRET` instruction tests the NT flag; if NT is 0, `IRET` returns from an interrupt procedure without a task switch. If NT is 1, a task switch occurs; NT = 1 indicates that the current task's TSS has a valid back link to the previous TSS.

**IOPL** (bits 12-13)

is the I/O Privilege Level field. `IOPL` specifies the highest privilege level (0, 1, 2, or 3) from which I/O instructions can be executed directly. Task switches can change the setting of the `IOPL` field, as do the `POPF` and `IRET` instructions executed at privilege level 0.

**RF** (bit 16) is the Resume Flag. It is used to restart program execution after a debug fault. RF is cleared after the successful execution of the faulting instruction.

TF, VM, NT, IOPL, and RF values cannot be set and reset by explicit processor instructions. To alter these values (assuming sufficient privilege in protected mode):

1. Use `PUSHF` to copy the `EFLAGS` register to the stack.
2. Set/clear these flag values in the stack image with the `BTS` or `BTR` instructions.
3. Use `POPF` to return the modified stack top to the `EFLAGS` register.

NT and `IOPL` values are irrelevant in real address mode. Only DF and TF are not subject to protection checking in protected mode.

## Processor Exceptions and Interrupts

Exceptions and interrupts alter the normal flow of program execution. Exceptions indicate erroneous conditions detected by the processor itself while it is executing instructions; interrupts usually indicate asynchronous events external to the processor.

Exceptions have two sources:

- Errors detected by the processor:
  - Faults detected before or during an instruction's execution that leave the machine in a state that permits the instruction to be restarted
  - Traps reported at the instruction boundary immediately after an instruction in which an exception was detected
  - Aborts reporting hardware errors and/or exceptions so severe that there is no clue about which instruction caused the error; restart of the program is not possible
- The instructions `INTO`, `INT 3`, `INT number`, and `BOUND` are sometimes called software interrupts because they can trigger exceptions. The processor detects the exceptions triggered by these instructions.

Interrupts also have two sources:

- Signals from the `INTR#` pin are maskable interrupts.
- Signals from the `NMI#` pin are non-maskable interrupts.

## Identifying Interrupts

The processor associates an identifying number with each interrupt or exception it recognizes. These numbers are in the range 0..31. Some of these numbers are unused but reserved by Intel for future expansion.

Identifiers of the maskable interrupts are determined by external interrupt controllers (such as Intel's 8259 Programmable Interrupt Controller); they are communicated to the processor during its interrupt-acknowledge cycle.

Processor exception names are formed from a cross-hatch character (#) followed by 2 letters and an optional error code in parentheses. Table A-2 summarizes the processor exceptions and interrupts.

**Table A-2. Processor Exceptions and Interrupts**

| Name | Cause                       | Interrupt Number | ASM386 Instruction That May Generate This Interrupt                      |
|------|-----------------------------|------------------|--------------------------------------------------------------------------|
|      | Divide error                | 0                | DIV, IDIV                                                                |
|      | Debug exception             | 1                | Any instruction                                                          |
|      | NMI# signal                 | 2                | (non-maskable external interrupt)                                        |
|      | 1-byte INT opcode           | 3                | INT                                                                      |
|      | 2-byte interrupt            | 32-255           | INT <i>number</i>                                                        |
|      | Interrupt on overflow       | 4                | INTO                                                                     |
|      | Array bounds check          | 5                | BOUND                                                                    |
| #UD  | Invalid opcode              | 6                | Any illegal instruction                                                  |
| #NM  | No math unit available      | 7                | ESC, WAIT                                                                |
| #DF  | Double fault                | 8                | Any instruction that can generate an exception                           |
|      | Coprocessor Segment Overrun | 9                | Any operand to an ESC instruction that wraps around the end of a segment |
| #TS  | Invalid task state          | 10               | JMP, CALL, any interrupt,                                                |
|      | segment (TSS)               |                  | IRET                                                                     |
| #NP  | Segment/gate                | 11               | Any segment register                                                     |
|      | not present                 |                  | modifier                                                                 |
| #SS  | Stack fault                 | 12               | Any instruction that references memory through SS                        |
| #GP  | General protection fault    | 13               | Any memory reference instruction or code fetch                           |
| #PF  | Page fault                  | 14               | Any memory reference instruction or code fetch                           |
|      | (reserved)                  | 15               |                                                                          |
| #MF  | Math fault                  | 16               | ESC, WAIT                                                                |

Interrupts 15 and 17-31 are reserved by Intel; interrupts 32-255 are available for external interrupts via the INTR# pin. In real address mode, interrupts 9-12 and 14-15 are reserved.

See also: Real address and virtual 8086 interrupts, *80386 Programmer's Reference Manual*

## Simultaneous Exceptions and Interrupts

The processor services interrupts and exceptions only between the end of one instruction and the beginning of the next. If more than one exception or interrupt is pending at an instruction boundary, the processor services them one at a time. The processor ranks exception/interrupt priority from highest to lowest as follows:

1. Faults except debug faults
2. Trap instructions `INTO`, `INT number`, `INT 3`
3. Debug traps for current instruction
4. Debug faults for next instruction
5. `NMI#` interrupts
6. `INTR#` interrupts

## Interrupt Descriptor Table

Both exceptions and interrupts have dedicated positions within the Interrupt Descriptor Table; the IDT is accessed by the processor IDT register, as shown in Figure A-21.

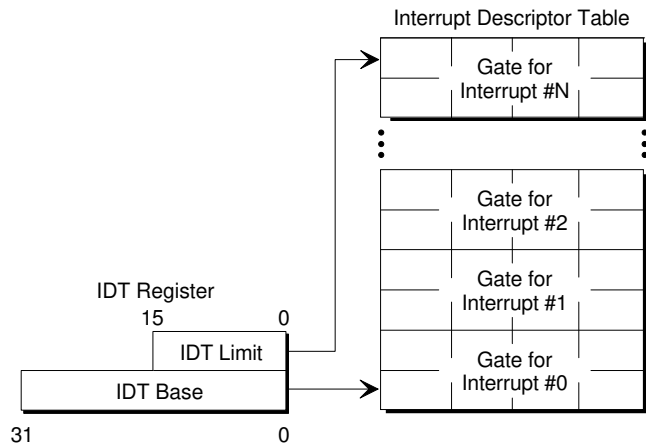

W-3458

**Figure A-21. Interrupt Descriptor Table and Register**

The IDT can reside anywhere in physical memory. The `LIDT`, `LIDTW`, or `LIDTD` instructions load the IDT register with a 6-byte pseudodescriptor operand that represents the linear base address and limit value of an IDT.

Interrupts located in an IDT are indexed by their `number * 8`. An IDT must contain descriptors only for interrupts that are used to call exception handlers; it can contain up to 256 descriptors.

The processor can use the interrupt or exception identifier as an index to an IDT with descriptors for task, interrupt, or trap gates. Figure A-22 illustrates the format for IDT gate descriptors.

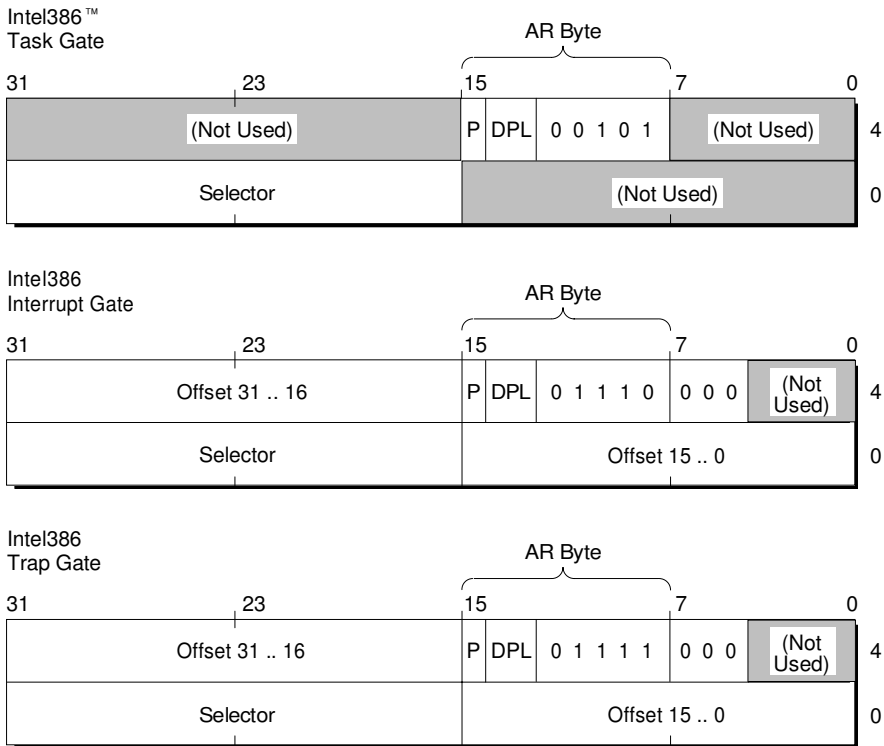

W-3459

**Figure A-22. IDT Gate Descriptors**

While executing instructions in protected or virtual 8086 mode, the processor checks all memory references for validity of addressing and of type of access. Violation of the processor memory protection rules generates exceptions or interrupts that can transfer program control to an exception handler.

## Error Codes for Exceptions

In protected mode, some exceptions cause the processor to pass a 16-bit error code to supply additional information for an exception handler.

In error code format for protection violations, bit values are as follows:

| <b>Bits</b> | <b>Meaning</b> |
|-------------|----------------|
| 31 to 16    | Undefined      |
| 15 to 3     | Selector Index |
| 2           | TI             |
| 1           | I              |
| 0           | EXT            |

The error code generally contains the selector of the segment that caused the protection violation. However, the RPL field (requesting privilege level) of the error code does not contain the privilege level.

The values of bits 0 and 1 are determined as follows:

**EXT (bit 0)** is 1 if the exception is detected during an interrupt caused by an event external to the program (i.e., an external interrupt, a single step, a floating-point coprocessor-not-present exception, or a floating-point coprocessor segment overrun). If bit 0 is set, the instruction pointed to by the saved CS:EIP address is not responsible for the error. Bit 0 is clear if the exception is detected in processing the regular instruction stream, even if the instruction stream is part of an external interrupt handling procedure or task.

**I (bit 1)** is 1 if the selector points to the Interrupt Descriptor Table. In this case, bit 2 can be ignored, and bits 3 through 15 contain the index into the IDT. Bit 1 is clear if the selector points to the Global or Local Descriptor Tables. In this case, bits 2 through 15 have their usual selector interpretation: TI (bit 2) selects the table (1 = Local, 0 = Global) and bits 3 through 15 are the index into the table.

In some cases, the processor passes an error code with no information in it. In these cases, all 16 bits of the error code are 0. The page fault exception passes an error code with significant information only for the low-order 3 bits. (See the descriptions of the individual exceptions following this section for details.)

The processor pushes the 16-bit error code onto the stack just before it transfers control to an exception handler. If stacks were switched as a result of the interrupt (if a privilege level change or task switch occurs), the error code appears on an exception handler's stack, not on the stack of the interrupted task.

## Processor Exception Conditions

This section summarizes the processor errors interrupts, exceptions and exception error codes, as well as the conditions that cause each error, interrupt, or exception.

### Interrupt 0 -- Divide Error

This fault occurs during a `DIV` or `IDIV` instruction when the divisor is zero. Note that a floating-point coprocessor zerodivide error generates the `#MF` exception, not an Interrupt 0.

### Interrupt 1 -- Debug Exceptions

The processor triggers this interrupt; whether the exception is a fault or a trap depends on the condition:

- Instruction address breakpoint fault
- Data address breakpoint trap
- General detect fault
- Single-step trap
- Task-switch breakpoint trap

The processor does not push an error code for the debug exception.

See also: debugging and the debug registers, *80386 Programmer's Reference Manual* breakpoints, Interrupt 3, in this appendix

### Interrupt 2 -- NMI

NMI is a non-maskable interrupt signaled via the `NMI#` pin. This signal is inhibited during the execution of `POP SS` or `MOV SS` in protected mode.

### Interrupt 3 -- Breakpoint

The `INT 3` instruction causes this trap. `INT 3` is a 1-byte instruction so debuggers can readily substitute `INT 3`'s opcode for another opcode in an executable segment.

## Interrupt 4 -- Overflow

The overflow trap occurs when the processor encounters an `INTO` instruction and the overflow flag (`OF` in `EFLAGS`) is set.

## Interrupt 5 -- Bounds Check

This fault occurs when the processor finds that a `BOUND` operand exceeds the specified limits, i.e. a signed array index exceeds the signed limits defined for it in a block of memory.

## #UD 6 -- Undefined Opcode (No Error Code)

This exception is generated when an invalid opcode is detected in the instruction stream. Under normal circumstances, the assembler will not produce invalid opcodes, nor will the processor allow a jump to a data segment; however, bad code can still be executed, causing the `#UD` exception, in the following cases:

- The first byte of an instruction is completely invalid (e.g., `64H`).
- The first byte indicates a two-byte opcode, and the second byte is invalid (e.g., `0FH` followed by `OFFH`).
- An invalid register is used with an otherwise valid opcode (e.g., `MOV CS,AX`).
- An invalid opcode extension is given in the `reg` field of the `ModRM` byte (e.g., `0F6H /1`).
- A register operand is given in an instruction that requires a memory operand (e.g., `LGDT AX`).
- A `LOCK` prefix is used with an unlockable instruction.

Because the offending opcode will always be invalid, it cannot be restarted. However, a `#UD` handler can be coded to implement an extension of the processor instruction set. Such a handler can advance the return pointer beyond the extended instruction and return control to the program after the extended instruction is emulated; however, the extensions may be incompatible with the processor.

## **#NM 7 -- No Math Unit Available (No Error Code)**

This exception occurs when the processor encounters a floating-point instruction and the EM (emulate) bit or the TS (task switched) bit of the machine status word is 1. Exception 7 also occurs when a `WAIT` instruction is encountered and both the MP (monitor coprocessor) and TS bits of the machine status word are 1.

Depending on the setting of the machine status word bits that caused this exception, an exception handler can emulate the floating-point coprocessor, or it can perform a context switch of the math processor to prepare the floating-point coprocessor for use by another task. The instruction that caused `#NM` can be restarted if the handler performs a context switch. If the handler emulates the math unit, it should advance the return pointer beyond the floating-point instruction that caused `#NM`.

## **#DF 8 -- Double Fault (Zero Error Code)**

This exception is generated when a second exception is detected while the processor is attempting to transfer control to an exception handler. For example, `#DF` is generated if the code segment containing an exception handler is marked "not present." It is also generated if calling an exception handler causes a stack overflow.

The saved CS:EIP points to the instruction that was executing when the double fault occurred. Because the `#DF` error code is 0, no information on the source of the exception is available. Restart is not possible.

`#DF` is never generated during the execution of an exception handler. An exception detected within the instruction stream of an exception handler causes one of the regular exceptions.

## **Interrupt 9 -- Coprocessor Segment Overrun**

This exception is raised in processor protected mode if the floating-point coprocessor overruns a page or segment limit while attempting to read/write the non-initial byte of an operand.

## #TS 10 -- Invalid Task State Segment (Selector Error Code)

This exception is generated when a task state is invalid. This occurs when:

- A task state segment is too small.
- The LDT indicated in a task state segment is invalid or not present.
- The CS, DS, ES, FS, GS, or SS indicated in a task state segment is invalid (task switch).
- A privileged stack in a task state segment is invalid.
- The back link in a task state segment is invalid (intertask IRET).

The error code passed to an exception handler contains the selector of the offending segment, which can either be the task state segment's or another segment's selector found within the task state segment. The instruction causing #TS can be restarted. #TS must be handled through a task gate so that an exception handler has a valid task environment in which to execute.

#TS is not generated when the CS, DS, ES, FS, GS, SS back link or privileged stack selectors point to a descriptor that is not present but is valid otherwise; in these cases, #NP or #SS is generated.

## #NP 11 -- Not Present (Selector Error Code)

This exception occurs when CS, DS, ES, FS, GS, or the task register (TR) is loaded with a descriptor that is marked not present but is otherwise valid. #NP can occur in a LLDT instruction, but not when the processor attempts to load the LDT register in a task switch (this causes the #TS exception). #NP also occurs when attempting to use a gate that is marked "not present."

If #NP is detected during the loading of CS, DS, ES, FS, or GS in a task switch, the exception occurs in the new task, and the IRET from an exception handler jumps directly to the next instruction in the new task.

The #NP error code is the selector of the descriptor that is marked "not present."

An #NP exception handler can be used to implement a virtual memory system. The operating system can swap inactive memory segments to a mass storage device such as a disk. An application program need not be informed of this. When the program attempts to access the swapped-out memory segment, the #NP handler can be invoked, the segment brought back into memory, and the offending instruction restarted.

## #SS 12 -- Stack Fault (Selector or Zero Error Code)

This exception is generated when a limit violation is detected in addressing through the SS register. It can occur for stack-oriented instructions such as `PUSH` or `POP`, as well as for other types of memory references using SS, such as `MOV EAX,[EBP+28]`.

#SS can also occur for an `ENTER` instruction when there is not enough space on the stack for the indicated local variable space, even if the stack exception is not triggered by pushing (E)BP or copying the display stack. Therefore, a stack exception can indicate a stack overflow, a stack underflow, or a wild offset. The error code is 0 in these cases.

#SS is also generated during an attempt to load SS with a descriptor that is marked "not present" but is otherwise valid. This can occur in a task switch, an interlevel call, an interlevel return, a move to SS, or a pop to SS. The error code is not 0 in these cases. An interlevel call deals with two stacks; #SS can occur on either one of them. They are distinguished by the error code. If #SS is caused by a "not present" condition or by overflow on the new stack in an interlevel call, the error code contains the selector of the segment that caused the exception. Otherwise, the error code is 0.

#SS is never generated when addressing through the DS, ES FS, or GS registers, even if the offending register points to the same segment as the SS register.

## #GP 13 -- General Protection (Selector or Zero Error Code)

This exception is generated for all protection violations not covered by the other exceptions in this section.

#GP is generated by an attempt to do any of the following:

- Violate the privilege rules. For example, an occurrence of an interrupt or exception via a trap or interrupt from virtual 8086 mode to a privilege level other than 0 generates #GP.
- Address a memory location using an offset that exceeds the limit for the segment involved
- Jump to a data segment
- Write to a read-only segment
- Exceed the instruction length limit of 15 bytes
- Load SS with a selector for a system segment or a read-only segment when the selector does not come from a task state segment (#TS occurs if it does come from a task state segment.)
- Load DS, ES, FS, or GS with the descriptor of a system segment or a non-readable code segment
- Access memory via DS, ES, FS, or GS when the segment register contains a null selector
- Switch to a task marked "busy"
- Load CR0 with PG = 1 and PE = 0 (paging enabled, protection disabled)

If #GP occurred while a descriptor is being loaded, the error code contains the selector involved. Otherwise, the error code is 0. If the error code is not 0, the instruction can be restarted if the erroneous condition is corrected. If the error code is 0, either a limit violation, a write-protect violation, or an attempt to use an invalid segment register occurred. An invalid segment register contains a value from 0 to 3.

## #PF 14 -- Page Fault (Type of Fault)

This exception is generated when a page fault occurs. Paging can be enabled during protected mode or virtual 8086 mode (the PG bit of CR0 equals 1).

The program currently executing is faulted in a manner that allows the instruction to be restarted. When a page fault occurs, the CS and EIP register images point to the instruction causing the page fault, and the control register CR2 is loaded with the linear address causing the page fault.

The error code provides the following information in its lower three bits:

- Bit 0 (P) indicates whether a page fault was caused by a page not present (P=0), or by a page level protection violation (P=1).
- Bit 1 (W/R) indicates that the access causing the fault was a read (W/R = 0) or a write (W/R = 1).
- Bit 2 (U/S) indicates that the fault occurred while at User level (U/S = 1) or at Supervisor level (U/S = 0).

The remaining bits of the fault code provided by #PF are undefined.

## #MF 16 -- Math Fault (No Error Code)

This exception is generated when the floating-point coprocessor detects an error. The coprocessor signals an error by the `ERROR#` input pin leading from the floating-point coprocessor to the processor. The processor tests `ERROR#` at the beginning of most floating-point instructions and when a `WAIT` instruction is executed with the `EM` bit of the machine status word set to 0 (i.e., no emulation of the math unit). The floating-point instructions that do not cause the `ERROR#` pin to be tested are `FNCLEX`, `FNINIT`, `FNSAVE`, `FNSTCW`, `FNSTSW`, and `FNSTENV`.





# Sample Program **B**

---

This appendix contains:

- The source code for a program that switches from real address mode to protected mode.
- The listing generated by the ASM386 Macro Assembler for this program.

This example works on an Intel386 processor.

For an example of a program that uses the new instructions, see the *Program Development Templates*, order number 481894-001.

## Sample Source Code

```
$TITLE('Protected Mode Transition -- 386 initialization')
NAME RESET
;*****
;
; Upon reset the 386 starts executing at address 0FFFFFFF0H.
; The upper 12 address bits remain high until a FAR call or
; jump is executed.
;
; Assume the following:
;
;
; -a short jump at address 0FFFFFFF0H (placed there by the
; system builder) causes execution to begin at START in
; segment RESET-CODE.
;
;
; -segment RESET_CODE is based at physical address 0FFFF0000H,
; i.e. at the start of the last 64K in the 4G address space.
; Note that this is the base of the CS register at reset. If
; you locate ROMcode above this address, you will need to
; figure out an adjustment factor to address things within
; this segment.
;
;*****
$EJECT ;@newpage
```

```

; Define addresses to locate GDT and IDT in RAM.
; These addresses are also used in the BLD386 file that defines
; the GDT and IDT. If you change these addresses, make sure you
; change the base addresses specified in the build file.

GDTbase EQU 00001000H ; physical address for GDT base
IDTbase EQU 00000400H ; physical address for IDT base

PUBLIC GDT-EPROM
PUBLIC IDT-EPROM
PUBLIC START

DUMMY segment rw ; ONLY for ASM386 main module stack init
    DW 0
DUMMY ends

;*****
;
; Note: RESET_CODE must be USE16 because the 386 initially executes
; in real mode.
;

RESET_CODE segment er PUBLIC USE16

ASSUME DS:nothing, ES:nothing

;
; 386 Descriptor template
;
DESC STRUC
    lim_0_15 DW 0 ; limit bits (0..15)
    bas_0_15 DW 0 ; base bits (0..15)
    bas_16_23 DB 0 ; base bits (16..23)
    access DB 0 ; access byte
    gran DB 0 ; granularity byte
    bas_24_31 DB 0 ; base bits (24..31)
DESC ENDS

; The following is the layout of the real GDT created by BLD386.
; It is located in EPROM and will be copied to RAM.
;
; GDT[0] ... NULL
; GDT[1] ... Alias for RAM GDT
; GDT[2] ... Alias for RAM IDT
; GDT[2] ... initial task TSS
; GDT[3] ... initial task TSS alias
; GDT[4] ... initial task LDT
; GDT[5] ... initial task LDT alias

```

```

;
; define entries in GDT and IDT.

GDT_ENTRIES EQU 8
IDT_ENTRIES EQU 32

; define some constants to index into the real GDT

GDT_ALIAS EQU 1*SIZE DESC
IDT_ALIAS EQU 2*SIZE DESC
INIT_TSS EQU 3*SIZE DESC
INIT_TSS_A EQU 4*SIZE DESC
INIT_LDT EQU 5*SIZE DESC
INIT_LDT_A EQU 6*SIZE DESC

;
; location of alias in INIT_LDT

INIT_LDT_ALIAS EQU 1*SIZE DESC

;
; access rights byte for DATA and TSS descriptors

DS_ACCESS EQU 10010010B
TSS_ACCESS EQU 10001001B

;
; This temporary GDT will be used to set up the real GDT in RAM.

Temp_GDT LABEL BYTE ; tag for begin of scratch GDT

NULL_DES DESC <> ; NULL descriptor

; 32-Gigabyte data segment based at 0
FLAT_DES DESC <0FFFFH,0,0,92h,0CFh,0>

GDT_eprom DP ? ; Builder places GDT address and limit
; in this 6 byte area.

IDT_eprom DP ? ; Builder places IDT address and limit
; in this 6 byte area.

```

```

;
; Prepare operand for loading GDTR and LDTR.

TGDT_pword LABEL PWORD      ; for temp GDT
    DW end_Temp_GDT-Temp_GDT -1
    DD 0

GDT_pword LABEL PWORD      ; for GDT in RAM
    DW GDT_ENTRIES * SIZE DESC -1
    DD GDTbase

IDT_pword LABEL PWORD      ; for IDT in RAM
    DW IDT_ENTRIES * SIZE DESC -1
    DD IDTbase

end_Temp_GDT LABEL BYTE

;
; Define equates for addressing convenience.

GDT_DES_FLAT EQU DS:GDT_ALIAS +GDTbase
IDT_DES_FLAT EQU DS:IDT_ALIAS +GDTbase

INIT_TSS_A_OFFSET EQU DS:INIT_TSS_A
INIT_TSS_OFFSET EQU DS:INIT_TSS

INIT_LDT_A_OFFSET EQU DS:INIT_LDT_A
INIT_LDT_OFFSET EQU DS:INIT_LDT

; define pointer for first task switch

ENTRY_POINTER LABEL DWORD
    DW 0, INIT_TSS

;*****
;
; Jump from reset vector to here.

START:

    CLI      ;disable interrupts
    CLD      ;clear direction flag

    LIDT NULL_des ;force shutdown on errors

```

```

;
; move scratch GDT to RAM at physical 0

XOR DI,DI
MOV ES,DI                                ;point ES:DI to physical location 0

MOV SI,OFFSET Temp_GDT
MOV CX,end_Temp_GDT-Temp_GDT            ;set byte count
INC CX

;
; move table

REP MOVSB BYTE PTR ES:[DI],BYTE PTR CS:[SI]

LGDT  tGDT_pword                          ;load GDTR for Temp. GDT
   ;(located at 0)

; switch to protected mode

MOV EAX,CR0                              ;get current CR0
ADD EAX,1                                 ;set PE bit
MOV CR0,EAX                              ;begin protected mode

;
; clear prefetch queue

JMP SHORT flush
flush:

; set DS,ES,SS to address flat linear space (0 ... 4GB)

MOV BX,FLAT_DES-Temp_GDT
MOV DS,BX
MOV ES,BX
MOV SS,BX

;
; initialize stack pointer to some (arbitrary) RAM location

MOV ESP, OFFSET end_Temp_GDT

;
; copy eprom GDT to RAM

MOV ESI,DWORD PTR GDT_eprom +2           ; get base of eprom GDT
   ; (put here by builder).

MOV EDI,GDTbase                          ; point ES:EDI to GDT base in RAM.

```

```

MOV CX,WORD PTR gdt_eprom +0      ; limit of eprom GDT
INC CX
SHR CX,1                          ; easier to move words
CLD
REP MOVSB  WORD PTR ES:[EDI],WORD PTR DS:[ESI]

;
; copy eprom IDT to RAM
;
MOV ESI,DWORD PTR IDT_eprom +2    ; get base of eprom IDT
                                   ; (put here by builder)

MOV EDI,IDTbase                   ; point ES:EDI to IDT base in RAM.

MOV CX,WORD PTR idt_eprom +0      ; limit of eprom IDT
INC CX
SHR CX,1
CLD
REP MOVSB  WORD PTR ES:[EDI],WORD PTR DS:[ESI]

; switch to RAM GDT and IDT
;
LIDT IDT_pword
LGDT GDT_pword

;
MOV BX,GDT_ALIAS                  ; point DS to GDT alias
MOV DS,BX
;
; copy eprom TSS to RAM
;
MOV BX,INIT_TSS_A                ; INIT_TSS_A descriptor base
                                   ; has RAM location of INIT_TSS.

MOV ES,BX                         ; ES points to TSS in RAM

MOV BX,INIT_TSS                   ; get initial task selector
LAR DX,BX                         ; save access byte
MOV [BX].access,DS_ACCESS        ; set access as data segment
MOV FS,BX                         ; FS points to eprom TSS

XOR SI,SI                         ; FS:SI points to eprom TSS
XOR DI,DI                         ; ES:DI points to RAM TSS

MOV CX,[BX].lim_0_15             ; get count to move
INC CX

```

```

;
; move INIT_TSS to RAM.

REP MOVSB BYTE PTR ES:[DI],BYTE PTR FS:[SI]

MOV [BX].access,DH ; restore access byte

;
; change base of INIT_TSS descriptor to point to RAM.

MOV AX,INIT_TSS_A_OFFSET.bas_0_15
MOV INIT_TSS_OFFSET.bas_0_15,AX
MOV AL,INIT_TSS_A_OFFSET.bas_16_23
MOV INIT_TSS_OFFSET.bas_16_23,AL
MOV AL,INIT_TSS_A_OFFSET.bas_24_31
MOV INIT_TSS_OFFSET.bas_24_31,AL

;
; change INIT_TSS_A to form a save area for TSS on first task
; switch. Use RAM at location 0.

MOV BX,INIT_TSS_A
MOV WORD PTR [BX].bas_0_15,0
MOV [BX].bas_16_23,0
MOV [BX].bas_24_31,0
MOV [BX].access,TSS_ACCESS
MOV [BX].gran,0
LTR BX ; defines save area for TSS

;
; copy eprom LDT to RAM
;

MOV BX,INIT_LDT_A ; INIT_LDT_A descriptor has
; base address in RAM for INIT_LDT.

MOV ES,BX ; ES points LDT location in RAM.

MOV AH,[BX].bas_24_31
MOV AL,[BX].bas_16_23
SHL EAX,16
MOV AX,[BX].bas_0_15 ; save INIT_LDT base (ram) in EAX

MOV BX,INIT_LDT ; get initial LDT selector
LAR DX,BX ; save access rights
MOV [BX].access,DS_ACCESS ; set access as data segment
MOV FS,BX ; FS points to eprom LDT

XOR SI,SI ; FS:SI points to eprom LDT
XOR DI,DI ; ES:DI points to RAM LDT
MOV CX,[BX].lim_0_15 ; get count to move
INC CX

```

```

;
; move initial LDT to RAM

REP MOVSB BYTE PTR ES:[DI],BYTE PTR FS:[SI]

MOV [BX].access,DH          ; restore access rights in
                           ; INIT_LDT descriptor

;
; change base of alias (of INIT_LDT) to point to location in RAM.

MOV ES:[INIT_LDT_ALIASES].bas_0_15,AX
SHR EAX,16
MOV ES:[INIT_LDT_ALIASES].bas_16_23,AL
MOV ES:[INIT_LDT_ALIASES].bas_24_31,AH
;
; now set the base value in INIT_LDT descriptor

MOV AX,INIT_LDT_A_OFFSET.bas_0_15
MOV INIT_LDT_OFFSET.bas_0_15,AX
MOV AL,INIT_LDT_A_OFFSET.bas_16_23
MOV INIT_LDT_OFFSET.bas_16_23,AL
MOV AL,INIT_LDT_A_OFFSET.bas_24_31
MOV INIT_LDT_OFFSET.bas_24_31,AL

;
; Now GDT, IDT, initial TSS and initial LDT are all set up.
;
; Start the first task!
;
JMP ENTRY_POINTER

RESET_CODE ends
END START, SS:DUMMY,DS:DUMMY

```

## Sample Listing

The following pages are a listing of the preceding program.

OS Vx.y (038-N) 80386 MACRO ASSEMBLER Protected Mode Transition -- 386 initialization  
09:37:35 11/11/87 PAGE 1

OS Vx.y (038-N) 80386 MACRO ASSEMBLER Xnnn, ASSEMBLY OF MODULE RESET  
OBJECT MODULE PLACED IN RESET.OBJ  
ASSEMBLER INVOKED BY: C:\TSTASM\ASM386.EXE RESET.SRC

```
LOC  OBJ                LINE  SOURCE
                                1 +1 $TITLE('Protected Mode Transition -- 386
                                initialization')
                                2  NAME RESET
                                3
                                4
                                5
;*****
                                6  ;
                                7  ; Upon reset the 386 starts executing at address
                                8  ; 0FFFFFF0H. The upper 12 address bits remain high
                                9  ; until a FAR call or jump is executed.
                               10  ;
                               11  ; Assume the following:
                               12  ;
                               13  ;
                               14  ; - a short jump at address 0FFFFFF0H (placed there by
                               15  ; the system builder) causes execution to begin at
                               16  ; START in segment RESET_CODE.
                               17  ;
                               18  ;
                               19  ; - segment RESET_CODE is based at physical address
                               20  ; 0FFF0000H, i.e. at the start of the last 64K in the 4G
                               21  ; address space. Note that this is the base of the CS
                               22  ; register at reset. If you locate ROMcode above this
                               23  ; address, you will need to figure out an adjustment
                               24  ; factor to address things within this segment.
                               25  ;
                               26
;*****
                               27 +1 $EJECT ;@newpage
```

```

LOC  OBJ                LINE  SOURCE

                                28
                                29
                                30 ; Define addresses to locate GDT and IDT in RAM.
                                31 ; These addresses are also used in the BLD386 file that
                                32 ; defines the GDT and IDT. If you change these
                                33 ; addresses, make sure you change the base addresses
                                    specified in the build file.
                                34
1000                35  GDTbase  EQU  00001000H ; physical address for GDT base
0400                36  IDTbase  EQU  00000400H ; physical address for IDT base
                                37
                                38  PUBLIC  GDT_EEPROM
                                39  PUBLIC  IDT_EEPROM
                                40  PUBLIC  START
                                41
-----                42  DUMMY  segment rw ; ONLY for ASM386 main module stack init
00000000 0000      43  DW  0
-----                44  DUMMY  ends
                                45
                                46
;*****
                                47 ;
                                48 ; Note: RESET_CODE must be USE16 because the 386
                                49 ; initially executes in real mode.
                                50 ;
                                51
-----                52  RESET_CODE segment er PUBLIC USE16
                                53
                                54  ASSUME DS:nothing, ES:nothing
                                55
                                56 ;
                                57 ; 386 Descriptor template
                                58 ;
-----                59  DESC  STRUC
0000                60  lim_0_15 DW  0 ; limit bits (0..15)
0002                61  bas_0_15 DW  0 ; base bits (0..15)
0004                62  bas_16_23 DB  0 ; base bits (16..23)
0005                63  access DB  0 ; access byte
0006                64  gran  DB  0 ; granularity byte
-----                65  bas_24_31 DB  0 ; base bits (24..31)
                                66  DESC  ENDS
                                67
                                68 ; The following is the layout of the real GDT created by
                                69 ; BLD386. It is located in EPROM and will be copied to
                                    RAM.
    
```

```

70 ;
71 ; GDT[0] ... NULL
72 ; GDT[1] ... Alias for RAM GDT
73 ; GDT[2] ... Alias for RAM IDT
74 ; GDT[2] ... initial task TSS
75 ; GDT[3] ... initial task TSS alias
76 ; GDT[4] ... initial task LDT
77 ; GDT[5] ... initial task LDT alias
78
79 ;
80 ; define entries in GDT and IDT.
81
0008      82 GDT_ENTRIES EQU 8

```

OS Vx.y (038-N) 80386 MACRO ASSEMBLER Protected Mode Transition -- 386 initialization  
09:37:35 11/11/87 PAGE 3

```

LOC  OBJ          LINE  SOURCE
0020          83  IDT_ENTRIES EQU 32
          84
          85  ; define some constants to index into the real GDT
          86
0008          87  GDT_ALIAS  EQU 1*SIZE DESC
0010          88  IDT_ALIAS  EQU 2*SIZE DESC
0018          89  INIT_TSS   EQU 3*SIZE DESC
0020          90  INIT_TSS_A EQU 4*SIZE DESC
0028          91  INIT_LDT   EQU 5*SIZE DESC
0030          92  INIT_LDT_A EQU 6*SIZE DESC
          93
          94  ;
          95  ; location of alias in INIT_LDT
          96
0008          97  INIT_LDT_ALIAS EQU 1*SIZE DESC
          98
          99  ;
          100 ; access rights byte for DATA and TSS descriptors
          101
0092          102 DS_ACCESS  EQU 10010010B
0089          103 TSS_ACCESS EQU 10001001B
          104
          105
          106 ;
          107 ; This temporary GDT will be used to set up the real GDT
          in RAM.
          108
0000          109 Temp_GDT  LABEL BYTE ; tag for begin of scratch GDT
          110
0000 0000          111 NULL_DES  DESC <> ; NULL descriptor

```

```

0002 0000
0004 00
0005 00
0006 00
0007 00

112
113 ; 32-Gigabyte data segment based at 0
0008 FFFF 114 FLAT_DESC DESC <0FFFFH,0,0,92h,0CFh,0>
000A 0000
000C 00
000D 92
000E CF
000F 00

115
116
0010 ?????????????? 117 GDT_eprom DP ? ; Builder places GDT address and
118 ; limit in this 6 byte area.
119
0016 ?????????????? 120 IDT_eprom DP ? ; Builder places IDT address and
121 ; limit in this 6 byte area.
122
123 ;
124 ; Prepare operand for loading GDTR and LDTR.
125
001C 126 TGDT_pword LABEL PWORD ; for temp GDT
001C 2D00 127 DW end_Temp_GDT-Temp_GDT -1

```

OS Vx.y (038-N) 80386 MACRO ASSEMBLER Protected Mode Transition -- 386 initialization  
09:37:35 11/11/87 PAGE 4

```

LOC OBJ          LINE SOURCE
001E 00000000    128 DD 0
129
0022            130 GDT_pword LABEL PWORD ; for GDT in RAM
0022 3F00        131 DW GDT_ENTRIES * SIZE DESC -1
0024 00100000    132 DD GDTbase
133
0028            134 IDT_pword LABEL PWORD ; for IDT in RAM
0028 FF00        135 DW IDT_ENTRIES * SIZE DESC -1
002A 00040000    136 DD IDTbase
137
002E            138 end_Temp_GDT LABEL BYTE
139
140 ;
141 ; Define equates for addressing convenience.
142
1008:           143 GDT_DES_FLAT EQU DS:GDT_ALIAS +GDTbase
1010:           144 IDT_DES_FLAT EQU DS:IDT_ALIAS +GDTbase
145

```

```

0020:          146  INIT_TSS_A_OFFSET EQU DS:INIT_TSS_A
0018:          147  INIT_TSS_OFFSET EQU DS:INIT_TSS
          148
0030:          149  INIT_LDT_A_OFFSET EQU DS:INIT_LDT_A
0028:          150  INIT_LDT_OFFSET EQU DS:INIT_LDT
          151
          152
          153  ; define pointer for first task switch
          154
002E          155  ENTRY_POINTER LABEL DWORD
002E 0000     156  DW 0, INIT_TSS
0030 1800
          157
          158
;*****
          159  ;
          160  ; Jump from reset vector to here.
          161
0032          162  START:
          163
0032 FA       164  CLI           ;disable interrupts
0033 FC       165  CLD           ;clear direction flag
          166
0034 2E0F011E0000 R 167  LIDT NULL_des ;force shutdown on errors
          168
          169  ;
          170  ; move scratch GDT to RAM at physical 0
          171
003A 31FF     172  XOR DI,DI
003C 8EC7     173  MOV ES,DI       ;point ES:DI to physical location 0
          174
003E BE0000   R 175  MOV SI,OFFSET Temp_GDT
0041 B92E00   176  MOV CX,end_Temp_GDT-Temp_GDT ;set byte count
0044 41       177  INC CX
          178  ;
          179  ; move table
          180
0045 F32EA4   181  REP MOVS BYTE PTR ES:[DI],BYTE PTR CS:[SI]
OS Vx.y (038-N) 80386 MACRO ASSEMBLER Protected Mode Transition -- 386 initialization
09:37:35 11/11/87 PAGE 5

LOC OBJ          LINE SOURCE

          182
0048 2E0F01161C00 R 183  LGDT tGDT_pword ;load GDTR for Temp. GDT
          184  ;(located at 0)
          185
          186  ; switch to protected mode
          187
004E 660F20C0  188  MOV EAX,CRO ;get current CRO
0052 660501000000 189  ADD EAX,1 ;set PE bit

```

```

0058 660F22C0      190 MOV CR0,EAX          ;begin protected mode
                    191 ;
                    192 ; clear prefetch queue
                    193
005C EB00          194 JMP SHORT flush
005E              195 flush:
                    196
                    197 ; set DS,ES,SS to address flat linear space (0 ... 4GB)
                    198
005E BB0800        199 MOV BX,FLAT_DES-Temp_GDT
0061 8EDB          200 MOV DS,BX
0063 8EC3          201 MOV ES,BX
0065 8ED3          202 MOV SS,BX
                    203 ;
                    204 ; initialize stack pointer to some (arbitrary) RAM
                        location
                    205
0067 66BC2E000000 R 206 MOV ESP, OFFSET end_Temp_GDT
                    207
                    208 ;
                    209 ; copy eprom GDT to RAM
                    210
006D 662E8B361200 R 211 MOV ESI,DWORD PTR GDT_eprom +2 ; get base of eprom GDT
                    212 ; (put here by builder).
                    213
0073 66BF00100000 214 MOV EDI,GDTbase      ; point ES:EDI to GDT base in RAM.
                    215
0079 2E8B0E1000   R 216 MOV CX,WORD PTR gdt_eprom +0 ; limit of eprom GDT
007E 41            217 INC CX
007F D1E9          218 SHR CX,1             ; easier to move words
0081 FC            219 CLD
0082 F367A5       220 REP MOVSB WORD PTR ES:[EDI],WORD PTR DS:[ESI]
                    221
                    222 ;
                    223 ; copy eprom IDT to RAM
                    224 ;
0085 662E8B361800 R 225 MOV ESI,DWORD PTR IDT_eprom +2 ; get base of eprom IDT
                    226 ; (put here by builder)
                    227
008B 66BF00040000 228 MOV EDI,IDTbase      ; point ES:EDI to IDT base in RAM.
                    229
0091 2E8B0E1600   R 230 MOV CX,WORD PTR idt_eprom +0 ; limit of eprom IDT
0096 41            231 INC CX
0097 D1E9          232 SHR CX,1
0099 FC            233 CLD
009A F367A5       234 REP MOVSB WORD PTR ES:[EDI],WORD PTR DS:[ESI]
                    235
                    236 ; switch to RAM GDT and IDT

```

| LOC  | OBJ          | LINE  | SOURCE                                                 |
|------|--------------|-------|--------------------------------------------------------|
|      |              | 237   | ;                                                      |
| 009D | 2E0F011E2800 | R 238 | LIDT IDT_pword                                         |
| 00A3 | 2E0F01162200 | R 239 | LGDT GDT_pword                                         |
|      |              | 240   |                                                        |
|      |              | 241   | ;                                                      |
| 00A9 | BB0800       | 242   | MOV BX,GDT_ALIAS ; point DS to GDT alias               |
| 00AC | 8EDB         | 243   | MOV DS,BX                                              |
|      |              | 244   | ;                                                      |
|      |              | 245   | ; copy eprom TSS to RAM                                |
|      |              | 246   | ;                                                      |
| 00AE | BB2000       | 247   | MOV BX,INIT_TSS_A ; INIT_TSS_A descriptor base         |
|      |              | 248   | ; has RAM location of INIT_TSS.                        |
|      |              | 249   |                                                        |
| 00B1 | 8EC3         | 250   | MOV ES,BX ; ES points to TSS in RAM                    |
|      |              | 251   |                                                        |
| 00B3 | BB1800       | 252   | MOV BX,INIT_TSS ; get initial task selector            |
| 00B6 | 0F02D3       | 253   | LAR DX,BX ; save access byte                           |
| 00B9 | C6470592     | 254   | MOV [BX].access,DS_ACCESS ; set access as data segment |
| 00BD | 8EE3         | 255   | MOV FS,BX ; FS points to eprom TSS                     |
|      |              | 256   |                                                        |
| 00BF | 31F6         | 257   | XOR SI,SI ; FS:SI points to eprom TSS                  |
| 00C1 | 31FF         | 258   | XOR DI,DI ; ES:DI points to RAM TSS                    |
|      |              | 259   |                                                        |
| 00C3 | 8B0F         | 260   | MOV CX,[BX].lim_0_15 ; get count to move               |
| 00C5 | 41           | 261   | INC CX                                                 |
|      |              | 262   |                                                        |
|      |              | 263   | ;                                                      |
|      |              | 264   | ; move INIT_TSS to RAM.                                |
|      |              | 265   |                                                        |
| 00C6 | F364A4       | 266   | REP MOVSB BYTE PTR ES:[DI],BYTE PTR FS:[SI]            |
|      |              | 267   |                                                        |
| 00C9 | 887705       | 268   | MOV [BX].access,DH ; restore access byte               |
|      |              | 269   |                                                        |
|      |              | 270   | ;                                                      |
|      |              | 271   | ; change base of INIT-TSS descriptor to point to RAM.  |
|      |              | 272   |                                                        |
| 00CC | A12200       | 273   | MOV AX,INIT_TSS_A_OFFSET.bas_0_15                      |
| 00CF | A31A00       | 274   | MOV INIT_TSS_OFFSET.bas_0_15,AX                        |
| 00D2 | A02400       | 275   | MOV AL,INIT_TSS_A_OFFSET.bas_16_23                     |
| 00D5 | A21C00       | 276   | MOV INIT_TSS_OFFSET.bas_16_23,AL                       |
| 00D8 | A02700       | 277   | MOV AL,INIT_TSS_A_OFFSET.bas_24_31                     |
| 00DB | A21F00       | 278   | MOV INIT_TSS_OFFSET.bas_24_31,AL                       |
|      |              | 279   |                                                        |
|      |              | 280   | ;                                                      |
|      |              | 281   | ; change INIT_TSS_A to form a save area for TSS on     |
|      |              | 282   | ; first task switch. Use RAM at location 0.            |

```

283
00DE BB2000      284  MOV BX,INIT_TSS_A
00E1 C747020000  285  MOV WORD PTR [BX].bas_0_15,0
00E6 C6470400    286  MOV [BX].bas_16_23,0
00EA C6470700    287  MOV [BX].bas_24_31,0
00EE C6470589    288  MOV [BX].access,TSS_ACCESS
00F2 C6470600    289  MOV [BX].gran,0
00F6 0F00DB      290  LTR BX          ; defines save area for TSS
291

```

OS Vx.y (038-N) 80386 MACRO ASSEMBLER Protected Mode Transition -- 386 initialization  
09:37:35 11/11/87 PAGE 7

```

LOC  OBJ          LINE  SOURCE
292  ;
293  ; copy eprom LDT to RAM
294  ;
00F9 BB3000      295  MOV BX,INIT_LDT_A      ; INIT_LDT_A descriptor has
296                          ; base address in RAM for
                          ; INIT_LDT.
297
00FC 8EC3        298  MOV ES,BX              ; ES points LDT location in RAM.
299
00FE 8A6707      300  MOV AH,[BX].bas_24_31
0101 8A4704      301  MOV AL,[BX].bas_16_23
0104 66C1E010    302  SHL EAX,16
0108 8B4702      303  MOV AX,[BX].bas_0_15   ; save INIT_LDT base (ram) in EAX
304
010B BB2800      305  MOV BX,INIT_LDT        ; get initial LDT selector
010E 0F02D3      306  LAR DX,BX              ; save access rights
0111 C6470592    307  MOV [BX].access,DS_ACCESS ; set access as data segment
0115 8EE3        308  MOV FS,BX              ; FS points to eprom LDT
309
0117 31F6        310  XOR SI,SI              ; FS:SI points to eprom LDT
0119 31FF        311  XOR DI,DI              ; ES:DI points to RAM LDT
312
011B 8B0F        313  MOV CX,[BX].lim_0_15   ; get count to move
011D 41          314  INC CX
315  ;
316  ; move initial LDT to RAM
317
011E F364A4      318  REP MOVSB BYTE PTR ES:[DI],BYTE PTR FS:[SI]
319
0121 887705      320  MOV [BX].access,DH     ; restore access rights in
321                          ; INIT_LDT descriptor
322
323  ;
324  ; change base of alias (of INIT_LDT) to point to
      location in RAM.

```

```

325
0124 26A30A00          326  MOV ES:[INIT_LDT_ALIAS].bas_0_15,AX
0128 66C1E810          327  SHR EAX,16
012C 26A20C00          328  MOV ES:[INIT_LDT_ALIAS].bas_16_23,AL
0130 2688260F00        329  MOV ES:[INIT_LDT_ALIAS].bas_24_31,AH
330  ;
331  ; now set the base value in INIT_LDT descriptor
332
0135 A13200            333  MOV AX,INIT_LDT_A_OFFSET.bas_0_15
0138 A32A00            334  MOV INIT_LDT_OFFSET.bas_0_15,AX
013B A03400            335  MOV AL,INIT_LDT_A_OFFSET.bas_16_23
013E A22C00            336  MOV INIT_LDT_OFFSET.bas_16_23,AL
0141 A03700            337  MOV AL,INIT_LDT_A_OFFSET.bas_24_31
0144 A22F00            338  MOV INIT_LDT_OFFSET.bas_24_31,AL
339
340  ;
341  ; Now GDT, IDT, initial TSS and initial LDT are all
    ; set up.
342  ;
343  ; Start the first task!
344  ;
0147 2EFF2E2E00        R 345  JMP ENTRY_POINTER
346
OS Vx.y (038-N) 80386 MACRO ASSEMBLER Protected Mode Transition -- 386 initialization
09:37:35 11/11/87 PAGE 8

```

```

LOC  OBJ                LINE  SOURCE
-----
347  RESET_CODE ends
*** WARNING #377 IN 347, (PASS 2) SEGMENT CONTAINS PRIVILEGED INSTRUCTION(S)
348  END START, SS:DUMMY,DS:DUMMY
ASSEMBLY COMPLETE,     1 WARNING, NO ERRORS.

```





# Keywords And Reserved Words **C**

---

This appendix lists assembler keywords and reserved words. Keywords consist of processor and numeric coprocessor mnemonics. Reserved words consist of all predefined keywords except the mnemonics.

Programmer-defined mnemonics may be defined as aliases for keywords if (1) the programmer-defined substitute is equated to the keyword with the `EQU` directive and (2) the original keyword is then purged with the `PURGE` directive. Programmer-defined aliases may be substituted for assembler reserved words if they are defined with `EQU`. However, reserved words cannot be purged.

See also: `PURGE` directive, Chapter 4

Note that `AND`, `NOT`, `OR`, `XOR`, `SHR`, and `SHL` function as both processor instructions and assembler operators. As operators, they are considered reserved words that cannot be purged. As instructions, they may be aliased to an identifier with `EQU`; this will not affect the use of `AND`, `NOT`, `OR`, `XOR`, `SHR`, and `SHL` as operators.

**Table C-1. Assembler Keywords**

|         |         |         |       |        |
|---------|---------|---------|-------|--------|
| AAA     | FCOM    | FNSTSW  | JA    | LIDTD  |
| AAD     | FCOMP   | FPATAN  | JAE   | LIDTW  |
| AAM     | FCOMPP  | FPREM   | JB    | LLDT   |
| AAS     | FCOS    | FPTAN   | JBE   | LMSW   |
| ADC     | FDECSTP | FRNDINT | JC    | LOCK   |
| ADD     | FDISI   | FRSTOR  | JCXZ  | LODS   |
| AND     | FDIV    | FSAVE   | JE    | LODSB  |
| ARPL    | FDIVP   | FSCALE  | JECXZ | LODSD  |
| BOUND   | FDIVR   | FSETPM  | JG    | LODSW  |
| BSF     | FDIVRP  | FSIN    | JGE   | LOOP   |
| BSR     | FENI    | FSINCOS | JL    | LOOPE  |
| BSWAP   | FFREE   | FSQRT   | JLE   | LOOPNE |
| BT      | FIADD   | FST     | JMP   | LOOPNZ |
| BTC     | FICOM   | FSTCW   | JNA   | LOOPZ  |
| BTR     | FICOMP  | FSTENV  | JNAE  | LSL    |
| BTS     | FIDIV   | FSTP    | JNB   | LSS    |
| CALL    | FIDIVR  | FSTSW   | JNBE  | LTR    |
| CBW     | FILD    | FSUB    | JNC   | MOV    |
| CDQ     | FIMUL   | FSUBR   | JNE   | MOVS   |
| CLC     | FINCSTP | FSUBRP  | JNG   | MOVSB  |
| CLD     | FINIT   | FTST    | JNGE  | MOVSD  |
| CLI     | FIST    | FUCOM   | JNL   | MOVSW  |
| CLTS    | FISTP   | FUCOMP  | JNLE  | MOVSX  |
| CMC     | FISUB   | FUCOMPP | JNO   | MOVZX  |
| CMP     | FISUBR  | FWAIT   | JNP   | MUL    |
| CMPS    | FLD     | FXAM    | JNS   | NEG    |
| CMPSB   | FLD1    | FXCH    | JNZ   | NIL†   |
| CMPSD   | FLDCW   | FXTRACT | JO    | NOP    |
| CMPSW   | FLDENV  | FYL2X   | JP    | NOT    |
| CMPXCHG | FLDL2E  | FYL2XP1 | JPE   | OR     |
| CWD     | FLDL2T  | HLT     | JPO   | OUT    |
| CWDE    | FLDLG2  | IDIV    | JS    | OUTS   |
| DAA     | FLDLN2  | IMUL    | JZ    | OUTSB  |
| DAS     | FLDPI   | IN      | LAHF  | OUTSD  |
| DIV     | FLDZ    | INC     | LAR   | OUTSW  |
| ENTER   | FMUL    | INS     | LDS   | POP    |
| ESC     | FMULP   | INSB    | LEA   | POPA   |
| F2XM1   | FNCLEX  | INSD    | LEAVE | POPAD  |
| FABS    | FNDISI  | INSW    | LES   | POPF   |
| FADD    | FNENI   | INT     | LFS   | POPFD  |
| FADDP   | FNINIT  | INTO    | LGDT  | PUSH   |
| FBLD    | FNOP    | INVD    | LGDTD | PUSHA  |
| FBSTP   | FNSAVE  | INVLPG  | LGDTW | PUSHAD |
| FCHS    | FNSTCW  | IRET    | LGS   | PUSHF  |
| FCLEX   | FNSTENV | IRETD   | LIDT  | PUSHFD |

**Table C-1. Assembler Keywords (continued)**

|       |        |        |       |        |
|-------|--------|--------|-------|--------|
| RCL   | SCASD  | SETNE  | SHL   | STR    |
| RCR   | SCASW  | SETNGE | SHLD  | SUB    |
| REP   | SETA   | SETNL  | SHR   | TEST   |
| REPE  | SETAE  | SETNLE | SHRD  | VERR   |
| REPNE | SETB   | SETNO  | SIDT  | VERW   |
| REPZ  | SETBE  | SETNP  | SIDTD | WAIT   |
| REPZ  | SETC   | SETNS  | SIDTW | WBINVD |
| RET   | SETE   | SETNZ  | SLDT  | XADD   |
| ROL   | SETG   | SETO   | SMSW  | XCHG   |
| ROR   | SETGE  | SETP   | STC   | XLAT   |
| SAHF  | SETL   | SETPE  | STD   | XLATB  |
| SAL   | SETLE  | SETPO  | STI   | XOR    |
| SAR   | SETNA  | SETS   | STOS  |        |
| SBB   | SETNAE | SETZ   | STOSB |        |
| SCAS  | SETNBE | SGDT   | STOSD |        |
| SCASB | SETNC  | SGDTW  | STOSW |        |

† NIL is the "empty imperative." The assembler generates no opcode when NIL is specified.

**Table C-2. Assembler Reserved Words**

|           |       |        |          |            |
|-----------|-------|--------|----------|------------|
| ABS       | DH    | EO     | NEAR     | SHORT      |
| AH        | DI    | EQ     | NOSEGFIX | SHR        |
| AL        | DL    | EQU    | NOT      | SI         |
| ALIGN     | DP    | ER     | NOTHING  | SIZE       |
| AND       | DQ    | ES     | OFFSET   | SP         |
| ASSUME    | DR0   | ESI    | OR       | SS         |
| AX        | DR1   | ESP    | ORG      | ST         |
| BH        | DR2   | EVEN   | PREFIX66 | STACKSEG   |
| BIT       | DR3   | EXTRN  | PREFIX67 | STACKSTART |
| BITOFFSET | DR6   | FAR    | PREFX    | STRUC      |
| BL        | DR7   | FS     | PROC     | TBYTE      |
| BP        | DS    | GE     | PROCLEN  | THIS       |
| BX        | DT    | GS     | PTR      | TR3        |
| BYTE      | DUP   | GT     | PUBLIC   | TR4        |
| CH        | DW    | HIGH   | PURGE    | TR5        |
| CL        | DWORD | HIGHW  | PWORD    | TR6        |
| CODEMACRO | DX    | LABEL  | QWORD    | TR7        |
| COMM      | EAX   | LE     | RECORD   | TYPE       |
| COMMON    | EBP   | LENGTH | RELB     | USE16      |
| CR0       | EBX   | LOW    | RELD     | USE32      |
| CR2       | ECX   | LOWW   | RELW     | WARNING    |
| CR3       | EDI   | LT     | RO       | WC         |
| CS        | EDX   | MASK   | RW       | WIDTH      |
| CX        | END   | MOD    | SEG      | WORD       |
| DB        | ENDM  | MODRM  | SEGFIX   | XOR        |
| DBIT      | ENDP  | NAME   | SEGMENT  | ?          |
| DD        | ENDS  | NE     | SHL      |            |



# ASCII Tables **D**

Table D-1 lists the ASCII character set according to its hexadecimal collating sequence. Table D-2 summarizes the ASCII non-printable characters and their respective functions.

**Table D-1. ASCII Collating Sequence**

| Hex Value | ASCII Character | Hex Value | ASCII Character |
|-----------|-----------------|-----------|-----------------|
| 00        | NUL             | 17        | ETB             |
| 01        | SOH             | 18        | CAN             |
| 02        | STX             | 19        | EM              |
| 03        | ETX             | 1A        | SUB             |
| 04        | EOT             | 1B        | ESC             |
| 05        | ENQ             | 1C        | FS              |
| 06        | ACK             | 1D        | GS              |
| 07        | BEL             | 1E        | RS              |
| 08        | BS              | 1F        | US              |
| 09        | HT              | 20        | SP              |
| 0A        | LF              | 21        | !               |
| 0B        | VT              | 22        | `               |
| 0C        | FF              | 23        | #               |
| 0D        | CR              | 24        | \$              |
| 0E        | SO              | 25        | %               |
| 0F        | SI              | 26        | &               |
| 10        | DLE             | 27        | '               |
| 11        | DC1             | 28        | (               |
| 12        | DC2             | 29        | )               |
| 13        | DC3             | 2A        | *               |
| 14        | DC4             | 2B        | +               |
| 15        | NAK             | 2C        | ,               |
| 16        | SYN             | 2D        | -               |

continued

**Table D-1 ASCII Collating Sequence (continued)**

| Hex Value | ASCII Character | Hex Value | ASCII Character |
|-----------|-----------------|-----------|-----------------|
| 2E        | .               | 57        | W               |
| 2F        | /               | 58        | X               |
| 30        | 0               | 59        | Y               |
| 31        | 1               | 5A        | Z               |
| 32        | 2               | 5B        | [               |
| 33        | 3               | 5C        | \               |
| 34        | 4               | 5D        | ]               |
| 35        | 5               | 5E        | +               |
| 36        | 6               | 5F        | ,               |
| 37        | 7               | 60        | `               |
| 38        | 8               | 61        | a               |
| 39        | 9               | 62        | b               |
| 3A        | :               | 63        | c               |
| 3B        | ;               | 64        | d               |
| 3C        | <               | 65        | e               |
| 3D        | =               | 66        | f               |
| 3E        | >               | 67        | g               |
| 3F        | ?               | 68        | h               |
| 40        | @               | 69        | i               |
| 41        | A               | 6A        | j               |
| 42        | B               | 6B        | k               |
| 43        | C               | 6C        | l               |
| 44        | D               | 6D        | m               |
| 45        | E               | 6E        | n               |
| 46        | F               | 6F        | o               |
| 47        | G               | 70        | p               |
| 48        | H               | 71        | q               |
| 49        | I               | 72        | r               |
| 4A        | J               | 73        | s               |
| 4B        | K               | 74        | t               |
| 4C        | L               | 75        | u               |
| 4D        | M               | 76        | v               |
| 4E        | N               | 77        | w               |
| 4F        | O               | 78        | x               |
| 50        | P               | 79        | y               |
| 51        | Q               | 7A        | z               |
| 52        | R               | 7B        | {               |
| 53        | S               | 7C        |                 |
| 54        | T               | 7D        | }               |
| 55        | U               | 7E        | [degree]        |
| 56        | V               | 7F        | DEL             |

**Table D-2. ASCII Non-Printable Characters**

| <b>Hex Value</b> | <b>Abbreviation</b> | <b>Meaning</b>            |
|------------------|---------------------|---------------------------|
| 00               | NUL                 | NULL Character            |
| 01               | SOH                 | Start of Heading          |
| 02               | STX                 | Start of Text             |
| 03               | ETX                 | End of Text               |
| 04               | EOT                 | End of Transmission       |
| 05               | ENQ                 | Enquiry                   |
| 06               | ACK                 | Acknowledge               |
| 07               | BEL                 | Bell                      |
| 08               | BS                  | Backspace                 |
| 09               | HT                  | Horizontal Tabulation     |
| 0A               | LF                  | Line Feed                 |
| 0B               | VT                  | Vertical Tabulation       |
| 0C               | FF                  | Form Feed                 |
| 0D               | CR                  | Carriage Return           |
| 0E               | SO                  | Shift Out                 |
| 0F               | SI                  | Shift In                  |
| 10               | DLE                 | Data Link Escape          |
| 11               | DC1                 | Device Control 1          |
| 12               | DC2                 | Device Control 2          |
| 13               | DC3                 | Device Control 3          |
| 14               | DC4                 | Device Control 4          |
| 15               | NAK                 | Negative Acknowledge      |
| 16               | SYN                 | Synchronous Idle          |
| 17               | ETB                 | End of Transmission Block |
| 18               | CAN                 | Cancel                    |
| 19               | EM                  | End of Medium             |
| 1A               | SUB                 | Substitute                |
| 1B               | ESC                 | Escape                    |
| 1C               | FS                  | File Separator            |
| 1D               | GS                  | Group Separator           |
| 1E               | RS                  | Record Separator          |
| 1F               | US                  | Unit Separator            |
| 20               | SP                  | Space                     |
| 7F               | DEL                 | Delete                    |

□ □ □



# Differences Between ASM386 and ASM286

# E

This appendix summarizes the major differences between the ASM386 and ASM286 assembly languages.

## New Processor Registers

The following processor registers are not part of the Intel286 processor register set:

- The 32-bit general registers -- EAX, ECX, EDX, EBX, EBP, ESI, EDI, and ESP
- The two "extra" segment registers, FS and GS
- The 32-bit instruction pointer register, EIP
- The 32-bit flag register, EFLAGS
- The control registers, CR0, CR1 (reserved), CR2, CR3 (PDBR)
- The debug and test registers, DR0, DR1, DR2, DR3, DR6, DR7, TR6, TR7

## New Instructions

The processor instruction set contains the following instructions that are not part of the Intel286 processor instruction set:

*BSF, BSR, BT, BTC, BTR, BTS, CDQ, CMPSD, CWDE, INSD, IRETD, JECXZ, LFS, LGDTT, LGDTW, LGS, LIDTD, LIDTW, LODSD, LSS, MOVSD, MOVXS, MOVZX, OUTSD, POPAD, POPFD, PUSHAD, PUSHFD, SCASD, SET, SETAE, SETB, SETC, SETE, SETG, SETGE, SETL, SETLE, SETNA, SETNAE, SETNB, SEGNB, SETNC, SETNE, SETNG, SETNGE, SETNL, SETNLE, SETNO, SETNP, SETNS, SETNZ, SETO, SETP, SETPO, SETPE, SETS, SETZ, SGDTT, SGDTW, SHLD, SIDTD, SIDTW, SHRD, STOSD*

See also: Processor instructions, Chapter 6

The floating-point coprocessor instruction set contains the following instructions that are not part of the Intel287 coprocessor (and the ASM286) instruction set:

FCOS, FPREM1, FUCOM, FUCOMP, FUCOMPP, FSIN, FSINCOS

The Intel287 coprocessor FSETPM instruction is an Intel387 coprocessor FNOP.

See also: Floating-point coprocessor instruction set, Chapter 7

## Processor Paging Mechanism

The processor has a paging mechanism, an optional addressing structure that can be used in protected mode and virtual 8086 mode, but not in real address mode.

See also: Paging, *80386 Programmer's Reference Manual*

## Addressing Differences

- The processor and ASM386 allow both 16-bit and 32-bit addressing. Each ASM386 segment is given a use attribute: USE32 specifies that the assembler should generate 32-bit offsets for logical addresses in the segment and USE16 specifies that the assembler should generate 16-bit offsets. The default is USE32, but 32-bit addressing can be used to access 16-bit logical addresses and vice versa. The USE32 default can be overridden by specifying USE16 in a segment definition or for the whole module with an assembler control.
- The processor and assembler allow you to use any general register as a base or index register (except ESP). This differs from the Intel286 processor and ASM286, for which only the registers BX, BP, SI, or DI could be used as base or index registers.
- The processor and assembler permit index scaling, in which the contents of an index register can be multiplied by a factor of 1, 2, 4, or 8. Scaling is not available in ASM286.
- The EVEN assembler directive aligns to dword boundaries in USE32 segments. In USE16 segments, EVEN aligns to word boundaries as it does in ASM286.

See also: Addressing information, Chapter 5  
index registers, Chapter 5

## Data Types

Two new data types are available in the assembler that are not available in ASM286 -- the `BIT` and `PWORD` data types. These are defined with the assembler directives `DBIT` and `DP`, respectively.

See also: Data types, Chapter 4

## Bit Manipulation

The `BIT` data type allows programmers to directly access and change individual bits, a feature that is not available with ASM286 and the Intel286 processor.

However, you need not declare data as type `BIT` in order to use the processor bit instructions (`BT`, `BTS`, `BTR`, `BTC`, `BSF`, and `BSR`). These instructions provide direct control over individual bits in bit strings. The `BITOFFSET` operator can return the offset of a structure field of type `BIT`.

See also: `BITOFFSET` operator, Chapter 5

## Assembler Directives

The assembler includes the `COMM` directive for variables and labels shared across modules. This directive supports the assembler interface to C language programs.

See also: `COMM` directive, Chapter 3

ASM386 includes the `ALIGN` directive to set the location counter to a value that is evenly divisible by the specified number for alignment of subsequent code or data.

## Assembler Operators

The following assembler operators are not part of ASM286:

- `HIGHW` and `LOWW` return the high-or low-order word of a dword operand, respectively.
- `BITOFFSET` returns the bit offset from the nearest lower byte address of a structure field of type `BIT`.

## Assembler Arithmetic

The assembler evaluates expressions in 64-bit two's complement integer arithmetic. ASM286 evaluates expressions with 17-bit arithmetic and truncates fractions to zero.

## Prefix66 and Prefix67 Codemacro Directives

Assembler codemacro definitions may include two new directives:

`PREFIX66` tells the assembler to generate operand size prefix bytes, if necessary.

`PREFIX67` tells the assembler to generate address size prefix bytes, if necessary.

`PREFIX66` allows codemacros to reference operands whose type implies a different `USE` attribute than the segment of the codemacro call. `PREFIX67` allows codemacros to reference operands whose defining segment has a different `USE` attribute than the segment of the codemacro call.



# Differences Between the Intel386™ and 376 Processors

# F

The 376 processor is a member of the Intel386 Family of Microprocessors. It has been streamlined for use in embedded applications.

The 376 processor can execute all 32-bit programs for the Intel386 processor that do not depend on paging or Virtual-86 mode.

The main differences between the Intel386 and 376 processors are summarized in the following chart:

| <b>Differences</b>    | <b>Intel386 Processor</b>           | <b>376 Processor</b>       |
|-----------------------|-------------------------------------|----------------------------|
| Speed                 | 16-25 MHz                           | 16 MHz                     |
| Physical address size | 4 Gigabytes                         | 16 Megabytes               |
| Bus size              | 32-bit data<br>32-bit addr          | 16-bit data<br>24-bit addr |
| Modes of Operation    | real/VM86/paging/<br>protected mode | protected (32-bit)<br>mode |
| Reset state           | real mode                           | protected (32-bit)<br>mode |
| Memory Management     | segments/pages/flat                 | segments/flat              |
| Pipelining            | 32-bit bus cycles                   | any bus cycle              |
| Coprocessor           | 387 Processor                       | 387SX Processor            |
| Package               | 132-pin PGA                         | 100-pin PQFP<br>88-pin PGA |

The following text explains these differences in more detail.

- The 376 processor starts executing code in protected mode. The Intel386 processor starts execution in real mode, which is then used to enter protected mode.
- The Intel386 processor can execute from 16-bit code segments (`USE16`) or 32-bit code segments (`USE32`). The 376 processor can only execute from 32-bit code segments and does not allow 16-bit code segments.

- The Intel386 processor allows both 16-bit stack segments (USE16) and 32-bit stack segments. The 376 processor allows only 32-bit stack segment.
- The Intel386 processor prefetch unit fetches code in 4-byte units. The 376 processor prefetch unit reads two bytes as one unit (like the 286 processor). In BS16 mode, the Intel386 processor takes two consecutive bus cycles to complete a prefetch request. If there is a data read or write request after the prefetch starts, the Intel386 processor will fetch all four bytes before addressing a new request.
- The Intel386 processor has a Virtual-86 mode so that real mode 8086 programs can execute as a task in protected mode. The 376 processor has no Virtual-86 mode.
- The Intel386 processor supports 286 processor call gates, interrupt gates, trap gates, and task state segments. The 376 processor does not support these 286 processor features.
- The Intel386 processor maps a 48-bit logical address into a 32-bit physical address by segmentation and paging. The 376 processor has no paging mechanism. The 376 processor maps its 48-bit logical address into a 24-bit physical address by segmentation only.
- The 376 processor 24-bit address bus limits segment size to 16 megabytes ( $2^{24}-1$ ) for 376 processor stack and code segments. The segment size for the Intel386 processor, as determined by its 32-bit address bus, is 4 gigabytes ( $2^{32}-1$ ).
- The 376 processor has no bus-sizing option for data. The Intel386 processor can select either a 32-bit data bus or a 16-bit data bus by use of the BS16# input. The 376 processor has a 16-bit data bus size.
- The 376 processor generates byte select signals on BHE# and BLE# (like the 8086 and the 286 processors) to distinguish upper and lower bytes on its 16-bit data bus. The Intel386 processor uses four, byte-select signals, BE0# through BE3#, to distinguish between the different bytes on its 32-bit bus.
- The contents of all 376 processor registers at reset are identical to the contents of the Intel386 processor registers at reset, except the DX register. The DX register contains a stepping identifier at reset. The following chart summarizes the value in the DX register after reset.

| Processor          | DH  | DL              |
|--------------------|-----|-----------------|
| Intel386 Processor | 3   | revision number |
| 376 Processor      | 33H | revision number |

- The 376 processor uses the Intel387 SX processor floating-point coprocessor for floating-point operations, while the Intel386 processor uses the 387 floating-point coprocessor.
- The Intel386 processor uses the  $A_{31}$  and  $M/IO\#$  pins to select its floating-point coprocessor. The 376 processor uses the  $A_{23}$  and  $M/IO\#$  pins to select its floating-point coprocessor.
- The  $NA\#$  pin operation in the 376 processor is identical to that of the  $NA\#$  pin on the Intel386 processor with one exception: the Intel386 processor's  $NA\#$  pin cannot be activated on 16-bit bus cycles (where  $BS16\#$  is LOW in the Intel386 processor case). The  $NA\#$  pin can be activated on any 376 processor bus cycle.

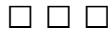



# Differences Between the Intel386 and Intel486™ Processors **G**

---

This appendix summarizes the major differences between the Intel386 and Intel486 processors.

The Intel486 processor is a member of the 32-bit 80x86 family of microprocessors. The Intel486 processor object code is compatible with all previous 80x86 chips, including the 8086, 186, 286, 376, and Intel386 processors. The Intel486 processor instruction set is fully compatible with the Intel386 processor instruction set. All programs written for the Intel386 processor can run without modification on the Intel486 processor. However, new features have been added to the Intel486 processor to increase performance and capabilities.

The major differences between the Intel386 and Intel486 processors are summarized below.

- The Intel486 processor integrates a number of architectural features which were formerly implemented with optional components:
  - A 387 numerics coprocessor compatible floating-point unit is added. All assembler floating-point instructions are accepted by the floating-point unit.
  - A data cache is implemented. The cache is transparent to software and keeps cache contents coherent with main memory.
- New cache control instructions are added to support the architectural features of the Intel486 processor:
  - `INVD` (invalidate data cache) and `WBINVD` (write back and invalidate data cache) allow a systems programmer to flush the data cache either destructively or with a write-back operation to main memory.
  - `INVLPG` (invalidate paging cache entry) allows a systems programmer to flush a single entry from the page translation cache (translation lookaside buffer).
- The following new instructions are added to aid the programmer.
  - `BSWAP` (byte swap) supports fast translation between "big endian" (highest order byte at lowest address) and "little endian" (highest order byte at highest address) data for compatibility with other data storage methods.

- `CMPXCHG` (compare exchange) is useful in multi-processor systems (with the `LOCK` prefix) to let the programmer indivisibly acquire a semaphore and identify its owner.
- `XADD` (exchange add) is useful (with the `LOCK` prefix) in multi-processor systems that partition algorithms across several processors.
- There are three new test registers for systems programming: TR3, TR4, and TR5. A privileged form of the `MOV` instruction enables systems programmers to access the new registers.
- The CR0 register (Control Register 0) contains five new bits. All bits are zero at reset and are so defined for Intel386 processor compatibility. Figure G-1 shows the Intel486 processor control registers.
  - Numeric Error (NE), bit 5. If cleared, user-defined floating-point error reporting through external interrupts (DOS compatibility) is possible. If set, standard floating-point error reporting through vector 16 is used.
  - Write Protect (WP), bit 16. If set, read-only pages are protected from being written into. If cleared, read-only pages may be written into.
  - Alignment Mask (AM), bit 18. AM masks the Alignment Check (AC) in the `EFLAGS` register. If set, AC is enabled. If cleared, AC is disabled.
  - Writes Transparent (WT), bit 29. If cleared, no write-through operation occurs when a write hits the cache; invalidate cycles are ignored. If set, write-through operations are enabled; invalidate cycles will remove a line from the cache.
  - Cache Enable (CE), bit 30. If cleared, the on-chip cache is disabled by not filling the cache on cache misses. If set, cache fill operations are enabled.
- The CR3 register (control register 3) and the Intel486 processor page table/directory contain two new bits. Figure G-1 shows the Intel486 processor control registers. Figure G-2 shows the Intel486 processor page table/directory format.
  - Write Through (PWT), bit 3. This bit acts as a status bit that software can use as a write-back page bit for an external cache. In this implementation, the bit indicates the current cache write-back policy. This bit is equivalent to PWT (bit 3) in the Intel486 processor page table/directory entry.
  - Cache Disable (PCD), bit 4. The Intel486 processor does not perform cache fill operations to any page in which this bit is set. This bit is equivalent to PCD (bit 4) in the Intel486 processor page table/directory entry.

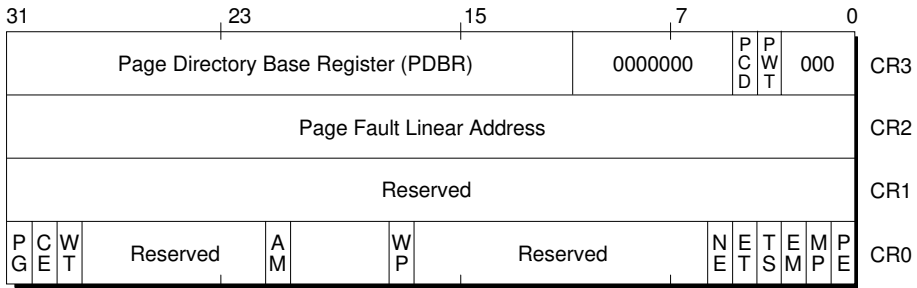

W-3461

**Figure G-1. Intel486 Processor Control Registers**

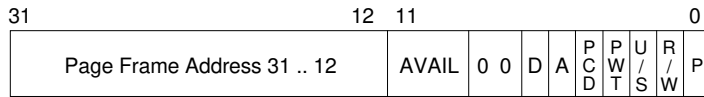

- P - Present
- R/W - Read/Write
- U/S - User/Supervisor
- A - Accessed
- D - Dirty
- AVAIL - Available for Systems Programmer Use
- PCD - Cache Disable
- PWT - Write Through

Note: 0 indicates Intel reserved. Do not define.

W-3462

**Figure G-2. Intel486 Processor Page Table/Directory Entry Format**

- The Intel486 processor `EFLAGS` register contains a new bit. Figure G-3 shows the Intel486 processor `EFLAGS` register.
  - Alignment Check (AC), bit 18. If set, enables the generation of faults if a memory reference is to a misaligned address. Alignment faults are generated only at privilege level 3.

All other Intel486 processor architecture specifications are identical to those of the Intel386 processor.

See also: Intel386 processor architecture, Appendix A



- #DF exception, 626
- #GP exception, 611, 629
- #MF exception, 631
- #NM exception, 626
- #NP exception, 627
- #PF exception, 630
- #SS exception, 628
- #TS exception, 627
- #UD exception, 625
- \$, location counter, 30, 113
- % macro metacharacter, 521
- (E)BP register, 575
- (E)DX:(E)AX, 270, 275, 278
- \* literal character, textmacros, 530, 552
- \* operator, 134, 138, 528
- + operator, 134, 140, 528
- operator, 134, 140, 528
- / operator, 134, 138, 528
- /digit notation, 194
- /r notation, 194
- < notation, 202
- <= notation, 202
- = notation, 202
- > notation, 202
- >= notation, 202
- ? initial value, 74, 89, 90, 91, 92, 94, 96, 100, 102, 110
- ? special character, 26
- @ character, textmacros, 556
- @ special character, 26
- [ ] pseudocode notation, 201
- [regname], addressing, 165
- \_ special character, 26
- 16-bit addressing, ModRM byte, 190
- 16-bit environments, floating-point coprocessor, 432
- 16-bit opcode, IP and OP environment, floating-point coprocessor, 439
- #DF exception, 626

- 32-bit addressing
  - ModRM byte, 191
  - SIB byte, 192
- 376 processor, differences from Intel386, 663

## A

- AAA instruction, 33, 176, 179, 212
- AAD instruction, 33, 176, 179, 214
- AAM instruction, 33, 176, 179, 215
- AAS instruction, 33, 176, 179, 216
- abort, exception, 618
- ABS type constant, 72, 128
- access attribute
  - compatible for segment, 54
  - segment, 51, 52
  - stack segment, 57
- access rights (AR) byte, 311, 334
- access rights byte, descriptor, 602
- accessed field, descriptor, 602
- accessing segment, ASSUME, 58
- ADC instruction, 176, 179, 218, 327
- ADD instruction, 176, 179, 212, 220, 267, 327
- addition operator, 140
- Addr pseudocode function, 202
- address expression, 123, 128
  - structure field type, 131
- address size attribute, instructions, 184
- address space, 596
- address translation, logical to physical, 600
- address, symbolic, 78
- addressing methods, 163
- addressing, bit in string, 170
- AddressSize pseudocode notation, 202
- ADI register, 260
- affine infinity, 445, 478
- AH register, 161, 270, 275, 310, 386, 593

AL register, 161, 216, 218, 220, 264, 267, 268, 270, 275, 278, 280, 329, 348, 355, 391, 409, 412, 414, 424, 593

alias  
    label, 117  
    symbol, 123

ALIGN directive, 30, 111, 113, 115

alphanumeric character, 24

AND instruction, 32, 176, 179, 222, 327, 615, 651

AND operator, 123, 134, 142, 528

ANONYMOUS, 41, 68

anonymous reference, 152  
    assembler-determined type, 130  
    default segment registers, 169

anonymous reference, codemacro call, 575

AR byte, 311, 334, 602, 605

arctangent, see FPATAN, 487

argument evaluation, nested textmacros, 527

arguments, textmacros, 525, 534

arithmetic, assembler, 83

ARPL instruction, 34, 176, 179, 181

array, 79, 85, 109, 149

ASCII character set, 655

ASM286, differences from ASM386, 659

ASM286, base and index registers, 660

ASM386, differences from ASM286, 659

ASSUME CS, NOTHING, 63, 64, 65

ASSUME directive, 29, 44, 50, 59, 145, 153, 575

ASSUME NOTHING, 63

attributes  
    code segment, 43  
    data segment, 42  
    instructions, 183  
    label, 112  
    segment, 51  
    stack or dsc segment, 58  
    structure field, 104  
    variable, 86

auxiliary carry flag, 178

auxiliary carry flag (AF), 310, 386, 614, 615

AX register, 46, 161, 214, 215, 218, 220, 252, 270, 275, 278, 280, 329, 348, 355, 363, 369, 391, 393, 409, 412, 414, 433, 592

## B

balanced text, textmacros, 525, 531

base address, segment, 60

base field, descriptor, 602

base field, SIB byte, 189

base registers, 129, 165, 166

base relocatable expression, 132

based addressing, 166

based indexed addressing, 167, 189

BCD, 80  
    digits, 214  
    format, 590  
    integer, floating-point coprocessor, 442

BH register, 161, 593

binary data, specification rules, 82

bit  
    string, 80, 87  
    string, format, 590  
    variable, 87

bit field, 80  
    format, 590  
    structure, 106

Bit Pseudocode function, 203

BIT type, 72, 79, 87, 150, 155, 661

BITOFFSET operator, 135, 147, 661

BL register, 161, 593

blank delimiter, textmacros, 553

BOUND, 226

BOUND instruction, 34, 618

bounds check fault, interrupt, 625

BP register, 46, 129, 161, 165, 273, 319, 363, 369

Bracket macro, 524, 530, 534

brackets  
    addition operator, 140  
    addressing, 165

breakpoint, interrupt, 624

BSF instruction, 33, 176, 179, 228

BSR instruction, 33, 176, 179, 230

BSWAP instruction, 177, 232

BT instruction, 33, 170, 176, 179, 233, 327

BTC instruction, 33, 170, 176, 179, 236, 327

BTR instruction, 33, 170, 176, 179, 239, 327

BTS instruction, 33, 170, 176, 179, 242, 327

busy bit, AR byte, 608

BX register, 46, 129, 161, 165, 363, 369, 424, 593  
byte string, 89  
BYTE type, 72, 79, 89, 150, 155

## C

### call

- codemacro, 560
- pattern, textmacros, 521, 529, 531
- textmacros, 521, 528, 556

call gate, 606

- interlevel procedure call, 120

CALL instruction, 34, 48, 111, 117, 119, 180, 245, 298, 384

carry flag, 178, 253, 257

carry flag (CF), 310, 348, 350, 353, 372, 386, 389, 406, 614

CBW instruction, 33, 176, 252

CDQ instruction, 33, 176, 265

CH register, 161, 593

character set, 24, 655

character string, 24, 27, 89, 90, 92, 94, 103, 106

character string, textmacros, 548, 549

CI macro, 525, 530, 550

CL register, 161, 372, 388, 593

CLC instruction, 32, 175, 253

CLD instruction, 32, 175, 254, 329, 394

CLI instruction, 175, 182, 255

clocking, assumptions, 200

close segment, 54

CLTS instruction, 34, 175, 182, 256

CMC instruction, 32, 176, 257

CMP instruction, 32, 176, 179, 258

CMPS instruction, 33, 176, 179, 260, 378, 576

CMPSB instruction, 260

CMPSD instruction, 260

CMPSW instruction, 260

CMPXCHG instruction, 176, 179, 263

CO macro, 525, 530, 550

code segment, 49

codemacro

- call, 579
- definition, 566
- modifiers, 569, 585
- operand, 560

- range specifiers, 571, 585, 586
- specifiers, 568

CODEMACRO directive, 560, 562, 566

collating sequence, ASCII, 655

combine attribute

- segment, 51, 53
- stack segment, 58

COMM directive, 29, 72, 74, 661

comment, 26

Comment macro, 524, 530, 537

COMMON attribute, 51, 53

compatible access attributes, 54

compound types, 99

condition bits, floating-point coprocessor, 435

constant

- expression, 83, 128
- external, 128
- global, 71, 123
- real, 484

continuation character, 26

control flags, CR0 register, 593

control transfers, protected, 603

control word, floating-point coprocessor, 435, 478, 482

coprocessor segment overrun, interrupt, 626

coprocessor synchronization, 418

coprocessors, 443

CPL, 280

CPL field, selector, 605

CR0 register, 161, 256, 341, 595, 659

CR2 register, 161, 341, 595, 659

CR3 register, 161, 341, 595, 659

CS register, 44, 50, 63, 67, 69, 113, 153, 161, 165, 367, 381, 593

- (E)IP initial value, 45, 69

CS:(E)IP register, 250

CWD instruction, 33, 176, 265

CWDE instruction, 33, 176, 252

CX register, 46, 161, 330, 331, 344, 357, 363, 369, 377, 379, 593

## D

DAA instruction, 33, 176, 179, 267

DAS instruction, 33, 176, 179, 268

data

- access, privilege levels, 605
- allocation, general syntax, 84
- assembler interpretation, 79
- formats, floating-point coprocessor, 440
- modular programs, 71
- segment, 42
- segment USE attribute, relocatability, 132
- storage formats, floating-point coprocessor, 588
- symbolic, 122
- type, 80
- type, floating-point coprocessor, 80
- values ,defining, 81

data segment, 49

DB directive, 30, 84, 89, 109, 561, 562, 578, 580

DBIT directive, 30, 84, 87, 109, 661

DD directive, 30, 84, 92, 109, 455, 561, 578, 580

debug exceptions, interrupt, 624

debug registers, 594

DEC instruction, 176, 179, 269, 327

decimal data, specification rules, 82

decimal real data, specification, 82

default

- EXTRN label type, 72
- module name, 68
- segment access, 52
- segment attributes, 51
- segment registers, indirect addressing, 169
- segment USE attribute, 52

DEFINE macro, 530

definitions, codemacros, 566

delimiter, ASM386, 25

delimiters

- textmacro call pattern, 531
- textmacros, 526, 553

denormalized exception, floating-point coprocessor, 437

descriptor access, gate, 606

descriptor formats, segments, 602

descriptor tables, 603

descriptor, segment, 601

descriptors, gate, 606

destination operand, 183

DH register, 161, 593

DI register, 46, 129, 161, 165, 167, 260, 283, 343, 363, 369, 377, 393, 407, 409

direct addressing, 164

direction flag, 254

direction flag (DF), 284, 407, 617

directives, 29

displacement, address, 185

displacement, addressing, 129, 165

DIV instruction, 176, 270

divide error, interrupt, 624

division operator, 138

DL register, 161, 593

dot operator, 85, 105, 107, 108, 580

dot-shift, 563, 580

double precision real, floating-point coprocessor, 440

DP directive, 30, 84, 94, 109, 561, 578, 661

DPL field, descriptor, 602, 606

DQ directive, 30, 84, 96, 109, 455

DR0 register, 341, 659

DR1 register, 341, 659

DR2 register, 341, 659

DR3 register, 341, 659

DR6 register, 341, 659

DR7 register, 341, 659

DS register, 45, 46, 50, 59, 67, 69, 161, 169, 340, 343, 357, 360, 367, 377, 424, 575, 593

Dsc segment, 58, 69

DT directive, 30, 84, 98, 109, 455

DUP clause, 30, 79, 85, 109

DW directive, 30, 84, 90, 109, 455, 561, 562, 578, 580

DWORD type, 72, 79, 91, 150, 155

DX register, 46, 161, 270, 275, 280, 283, 348, 355, 357, 363, 369, 592

## E

EAX register, 129, 161, 165, 218, 220, 252, 270, 275, 278, 280, 329, 348, 355, 363, 369, 391, 393, 409, 412, 414, 592, 659

EBP register, 129, 161, 165, 273, 319, 363, 369, 592, 659

EBX register, 129, 161, 165, 363, 369, 424, 592, 659  
 ECS register, 329  
 ECX register, 129, 161, 165, 332, 358, 363, 369, 377, 394, 410, 592, 659  
 EDI register, 129, 161, 165, 284, 344, 363, 369, 377, 393, 407, 409, 592, 659  
 EDX register, 129, 161, 165, 270, 275, 348, 369, 592, 659  
 effective address, 163, 165, 597  
 EFLAGS register, 365, 371, 593, 612, 659  
 EIP register, 45, 69, 308, 351, 381, 593, 659  
 ELSE, textmacro, 541  
 EM control flag, 595  
 encoding format, 185  
 END directive, 29, 44, 58, 69  
 ENDS, 29, 42, 51  
 ENTER instruction, 32, 178, 272, 319  
 entry point, program, 44, 69  
 environment, floating-point coprocessor, 431, 483  
 EO access, 52  
 EQ operator, 134, 141, 528, 541, 543  
 EQS macro, 524, 530, 541, 543, 546  
 EQU directive, 30, 71, 123, 144, 651  
 ER access, 52  
 error code  
     exceptions, 623  
     format, exceptions, 623  
 ES register, 42, 46, 59, 153, 161, 165, 169, 284, 314, 340, 343, 360, 367, 377, 393, 409, 575, 593  
 ESC, 182, 580  
 Escape macro, 524, 529, 530, 535  
 ESI register, 129, 161, 165, 254, 331, 344, 358, 592, 659  
 ESP register, 42, 45, 69, 129, 152, 161, 165, 177, 273, 361, 368, 369, 371, 575, 592, 659  
 ET control flag, 595  
 EVAL macro, 524, 530, 539  
 evaluation, textmacro calls, 556  
 EVEN directive, 30, 111, 114, 661  
 examples, program listing, 633  
 exceptions, 207, 618  
     causes, 624  
     double fault, 626  
     error code, 623  
     floating-point coprocessor, 434, 437, 463  
     floating-point coprocessor, fault, 631  
     general protection violation, 629  
     handling, floating-point coprocessor, 445  
     invalid TSS, 627  
     no floating-point coprocessor, 626  
     not present, 627  
     page fault, 630  
     priority, 621  
     stack fault, 628  
     undefined opcode, 625  
 EXIT macro, 524, 530, 544, 545  
 expression evaluation order, 136  
 expression evaluation, textmacros, 527, 539  
 expression, assembler evaluation, 83  
 EXT field, error code, 623  
 extended precision real, floating-point coprocessor, 440  
 external constant, 128  
 EXTRN, ABS constant, 133  
 EXTRN directive, 29, 72, 74

## F

F2XM1 instruction, 37, 452, 457  
 FABS instruction, 37, 449, 458  
 FADD instruction, 37, 459  
 FADDP instruction, 37, 459  
 far pointer format, 591  
 FAR procedure return, 384  
 FAR PUBLIC, procedures, 119  
 FAR type, 72, 78, 111, 116, 140, 150, 155  
 fault, exception, 618  
 FBLD instruction, 36, 446, 460  
 FBSTP instruction, 36, 446, 461  
 FCHS instruction, 37, 449, 462  
 FCLEX instruction, 38, 453, 463  
 FCOM instruction, 36, 435, 451, 464  
 FCOMP instruction, 36, 435, 451, 464  
 FCOMP instruction, 36, 435, 451, 464  
 FCOS instruction, 37, 452, 466  
 FDECSTP instruction, 38, 453, 467  
 FDISI 8087 instruction, 456  
 FDIV instruction, 37, 468  
 FDIVP instruction, 37, 468  
 FDIVR instruction, 37  
 FDIVRP instruction, 37, 468

- FENI 8087 instruction, 456
- FFREE instruction, 38, 453, 469
- FIADD instruction, 37, 470
- FICOM instruction, 36, 451, 471
- FICOMP instruction, 36, 451, 471
- FIDIV instruction, 37, 473
- FIDIVR instruction, 37, 473
- FIDVR instruction, 468
- field of structure, offset, 131
- field, record, 85, 99, 100
- field, structure, 85, 99, 104, 106
- FILD instruction, 36, 446, 474
- FIMUL instruction, 37, 475
- FINCSTP instruction, 38, 453, 476
- FINIT instruction, 453, 477
- FIST instruction, 36, 446, 479
- FISTP instruction, 36, 446, 479
- FISUB instruction, 37, 480
- FISUBR instruction, 37, 480
- flag value assignments, 178
- flags, 612
- FLAGS register, 365, 371, 593
- flat address space, 596
- FLD instruction, 36, 446, 481
- FLD1 instruction, 36, 447, 484
- FLDcon instruction, 456, 484
- FLDCW instruction, 38, 453, 482
- FLDENV instruction, 38, 431, 439, 453, 483
- FLDL2E instruction, 36, 447, 484
- FLDL2T instruction, 36, 447, 484
- FLDLG2 instruction, 36, 447, 484
- FLDLN2 instruction, 36, 447, 484
- FLDPI instruction, 36, 447, 484
- FLDZ instruction, 36, 447, 484
- floating-point coprocessor
  - context switch, 256
  - control word, 435, 478
  - data type, 80
  - double precision real, 82, 96
  - exceptions, 437, 445
  - extended precision real, 82, 98
  - long integer, 82, 96
  - machine state, 494, 496
  - packed decimal integer, 82, 98
  - short integer, 82, 93
  - single precision real, 82, 93
  - state after initialization, 478
  - Status word, 432, 478
  - tag word, 438, 478
  - word integer, 82
- floating-point stack, 430
- FMUL instruction, 37, 485
- FMULP instruction, 37, 485
- FNCLEX instruction, 38, 444, 453, 463
- FNDISI 8087 instruction, 456
- FNENI 8087 instruction, 456
- FNINIT instruction, 38, 444, 453, 477
- FNOP instruction, 38, 453, 486
- FNSAVE instruction, 38, 444, 453
- FNSTCW instruction, 38, 453, 505
- FNSTENV instruction, 38, 444, 453, 506
- FNSTSW instruction, 38, 433, 453, 507
- formal parameters
  - codemacros, 560, 568
  - in textmacro body, 531
  - textmacro definitions, 530
- FPATAN instruction, 37, 452, 487
- FPREM instruction, 37, 435, 449, 466, 489, 501, 502, 507
- FPREM1 instruction, 37, 435, 449, 466, 489, 501, 502, 507
- FPTAN instruction, 37, 452, 492
- frame pointer, 273, 319
- FRNDINT, 493
- FRNDINT instruction, 37, 449, 461
- FRSTOR, 494
- FRSTOR instruction, 431, 439, 453
- FS register, 42, 46, 50, 59, 161, 314, 340, 360, 367, 593, 659
- FSAVE instruction, 38, 431, 439, 453, 494, 495
- FSCALE instruction, 37, 449, 499
- FSETPM instruction, 38, 453, 500
- FSIN instruction, 37, 452, 501
- FSINCOS instruction, 37, 452, 502
- FSQRT instruction, 37, 449, 503
- FST instruction, 36, 446, 504
- FSTCW instruction, 38, 453, 505
- FSTENV instruction, 38, 431, 439, 453, 483, 506
- FSTP instruction, 36, 446, 504
- FSTSW instruction, 38, 433, 453, 472, 490, 507
- FSUB instruction, 37, 508

FSUBP instruction, 37, 508  
 FSUBR instruction, 37, 508  
 FSUBRP instruction, 37, 508  
 FTST instruction, 36, 435, 451, 509  
 FUCOM instruction, 36, 435, 451, 510  
 FUCOMP instruction, 36, 435, 451, 510  
 FUCOMPP instruction, 36, 435, 451, 510  
 FWAIT instruction, 38, 453, 463, 477, 495,  
 507, 512  
 FXAM instruction, 36, 435, 451, 507, 513  
 FXCH instruction, 36, 446, 514  
 FXTRACT, 515  
 FXTRACT instruction, 37, 449  
 FYL2X instruction, 37, 452, 517  
 FYL2XP1, 518  
 FYL2XP1 instruction, 37, 452

## G

gate descriptors, 604, 606  
 GDT, 603  
 GDTR register, 594, 603  
 GE operator, 134, 141, 528, 541, 543  
 general registers, 591  
 GES macro, 524, 530, 541, 543, 546  
 global constant, 123  
 GS register, 42, 46, 50, 59, 161, 314, 340, 360,  
 367, 593, 659  
 GT operator, 134, 141, 528, 541, 543  
 GTS macro, 524, 530, 541, 543, 546

## H

hexadecimal data, specification rules, 82  
 hexadecimal real data, specification, 82  
 HIGH operator, 134, 137, 528  
 HIGHW operator, 134, 137, 661  
 HLT instruction, 34, 181, 182, 274

## I

I field, error code, 623  
 I/O  
   address map, TSS, 610  
   permission bit map, 280, 284, 355,  
   358, 610

  predefined macros, 550  
   privilege level (IOPL), 617  
 ib, iw, id notation, 194  
 identifier delimiter, textmacros, 555  
 identifier, ASM386, 26  
 identifier, textmacro, 527  
 IDIV instruction, 176, 275  
 IDT gate, descriptor format, 622  
 IDT register, 622  
 IDTR register, 290, 594  
 IF macro, 528, 530, 541  
 imm32 notation, 197  
 imm8, imm16 notation, 196  
 immediate operand, 162, 185, 197  
 immediate operand, segment name, 52  
 implicit operands, 128  
 implicit reference, register, 48  
 implied blank, textmacro, 553  
 IMUL instruction, 176, 179, 277  
 IN instruction, 31, 173, 181, 280, 611  
 IN macro, 525, 530, 550  
 INC instruction, 176, 179, 282, 327  
 index field, selector, 603  
 index field, SIB byte, 189, 563  
 index registers, 129, 165, 167  
 indexed addressing, 167  
 indirect addressing, 164  
 infinite loops, textmacros, 545  
 infinities, floating-point coprocessor, 445  
 infinity control (IC), floating-point  
   coprocessor, 436  
 initial value  
   defining, 80  
   DS register, 69  
   instruction pointer, 70  
   stack pointer, 69  
 initializing  
   data segment register, 46  
   stack segment register, 47  
 input stream, macro processor, 556  
 INS instruction, 33, 173, 181, 283, 377,  
   576, 611  
 INSB instruction, 283  
 INSD instruction, 283  
 instruction, type, 150  
 instruction register, floating-point  
   coprocessor, 591

- instructions, floating-point coprocessor, by function, 31
- instructions, syntax, 182
- INSW instruction, 283
- INT instruction, 34, 180, 186, 286, 298, 618
- integer, 80, 89, 90, 92
  - floating-point coprocessor, 442
  - format, 590
- Intel287 floating-point coprocessor
  - long, short, and temporary reals, 440
- Intel386 processor
  - differences from 376, 663
  - differences from Intel486, 667
- Intel486 processor
  - differences from Intel386, 667
- interlevel procedure call, 119
- Interrupt Descriptor Table (IDT), 290
- interrupt flag (IF), 255, 617
- interrupt gate, 606
  - descriptor, 622
- interrupts, 209, 618, 621
  - causes, 624
  - indexing to, 622
  - priority, 621
  - reserved, 621
- intersegment jump or call, 113
- INTO instruction, 34, 180, 186, 286, 618
- INTR# pin, 618
- intrasegment jump or call, 112
- invalid exception, floating-point coprocessor, 437
- INVD instruction, 182, 292
- INVLPG instruction, 182, 293
- IOPermission pseudocode function, 204
- IOPL, 255, 284, 298, 355, 358
- IOPL field, 606, 613, 617
  - and I/O permission, 611
- IP register, 45, 69, 351, 381
- IRET instruction, 34, 180, 186, 294, 618
- IRETD instruction, 34, 180, 186, 294

## J

- JA instruction, 299
- JAE instruction, 299
- JB instruction, 299
- JBE instruction, 299

- JC instruction, 299
- Jcc instruction, 34, 111, 113, 117, 157, 176, 180, 259, 299, 415
- JCXZ instruction, 299, 380
- JE instruction, 299
- JECXZ instruction, 299, 380
- JG instruction, 299
- JGE instruction, 299
- JL instruction, 299
- JLE instruction, 299
- JMP instruction, 34, 111, 113, 117, 157, 180, 304
- JNA instruction, 299
- JNAE instruction, 299
- JNB instruction, 299
- JNBE instruction, 299
- JNC instruction, 299
- JNE instruction, 299
- JNG instruction, 299
- JNGE instruction, 299
- JNL instruction, 299, 301
- JNLE instruction, 299, 301
- JNO instruction, 299, 301
- JNP instruction, 299, 301
- JNS instruction, 299, 301
- JNZ instruction, 301
- JO instruction, 301
- JP instruction, 301
- JPE instruction, 301
- JPO instruction, 301
- JS instruction, 301
- JZ instruction, 299, 301

## K

- keywords, 651

## L

- label, 111
  - addressing offset, 129
  - attributes, 112
  - default EXTRN type, 72
  - FAR, 116
  - NEAR, 118

- relocatable in data segment, 132
- shared across modules, 71
- simplest definition, 116
- LABEL directive, 30, 111, 116
- labeled variable, 116
- LAHF instruction, 32, 174, 310
- LAR instruction, 34, 174, 179, 181, 311
- LDS instruction, 31, 174, 314, 417
- LDT, 603
- LDTR register, 594, 603
- LE operator, 134, 141, 528, 541, 543
- LEA instruction, 31, 174, 176, 317
- LEAVE instruction, 32, 178, 319
- LEN macro, 525, 530, 547
- LENGTH operator, 135, 149, 151
- LES instruction, 31, 174, 314, 417
- LES macro, 530, 541, 543, 546
- LFS instruction, 31, 174, 314, 417
- LGDT instruction, 34, 174, 181, 320
- LGDTW/LGDTD instruction, 34, 174, 181, 322
- LGS instruction, 31, 174, 314, 417
- LIDT instruction, 34, 174, 181, 182, 320, 622
- LIDTW/LIDTD instructions, 34, 174, 181, 182, 322
- Limit field, descriptor, 334, 602
- literal delimiters, textmacros, 526, 553
- literal scanning mode, textmacros, 522, 534, 536, 552
- LLDT instruction, 34, 174, 181, 324
- LMSW instruction, 34, 174, 182, 326
- loading
  - data segment registers, 46
  - stack segment register, 47
  - unnamed segment, 60
- LOCAL symbols, textmacros, 530
- location counter, 30, 111, 113, 144
- LOCK instruction prefix, 35, 182, 186, 327, 567
- LODS instruction, 33, 174, 329
- LODSB instruction, 329
- LODSD instruction, 329
- LODSW instruction, 329
- logical address, 44, 49, 78, 83, 163, 599
  - segment, 51
  - symbolic data, 60
- logical delimiter, 24

- logical expressions, textmacros, 527
- logical segment, 49
  - definition, 51
- logical space, 25
- long integer, floating-point coprocessor, 440
- long real, Intel287 coprocessor, 440
- LOOP instruction, 34, 180, 331, 379
- LOOPcond instruction, 34, 176, 180, 331
- LOW operator, 134, 137, 528
- LOWW operator, 134, 137, 661
- LSL instruction, 34, 174, 179, 181, 333
- LSS instruction, 31, 174, 314
- LT operator, 134, 141, 528, 541, 543
- LTR instruction, 34, 174, 182, 336
- LTS macro, 524, 530, 543, 546
- LTS operator, 541

## M

- m notation, 196, 201
- m14/28by notation, 455
- m16&32, m16&16, m32&32 notation, 199
- m16:16, m16:32 notation, 199
- m16j notation, 455
- m2by notation, 455
- m32j notation, 455
- m32r notation, 455
- m64j notation, 455
- m64r notation, 455
- m80d notation, 455
- m80r notation, 455
- m94/108by notation, 455
- machine state, floating-point coprocessor, 498
- macro
  - body, textmacro definitions, 530
  - call, 521, 528
  - call, with local list, 530
  - call, without arguments, 521
  - delimiters, 526
  - identifiers, 527
  - processor, scanning modes, 522
- MASK operator, 85, 135, 159
- maskable interrupts, 618
- MATCH macro, 525, 530, 549
- memory operand, 162
- memory organization, 49, 596
- METACHAR macro, 524, 530, 538

- metacharacter, textmacros, 521
- mnemonic, 123, 183
- mod field, ModRM byte, 188, 563
- MOD operator, 134, 138, 528
- modifiers, codemacros, 569, 585
- ModRM byte, 186, 188, 342, 454, 563, 577
- MODRM directive, 561, 563, 577
- module, ASM386, 67
  - combined segments, 53
  - default name, 68
  - shared variables or labels, 71
- modulo operator, 138
- moffs8, moffs16, moffs32 notation, 199
- MOV, 182
- MOV instruction, 31, 45, 161, 175, 338, 594
- MOVS instruction, 33, 175, 343, 378
- MOVSB instruction, 343
- MOVSD instruction, 343
- MOVSW instruction, 343
- MOVSX instruction, 31, 175, 176, 346
- MOVZX instruction, 31, 175, 176, 347
- MP control flag, 595
- MUL instruction, 176, 179, 215, 348
- multiplication operator, 138

## N

- n notation, 201
- NAME directive, 41, 67
- NE operator, 134, 141, 528, 541, 543
- near pointer format, 590
- NEAR procedure return, 384
- NEAR type, 72, 78, 111, 117, 140, 150, 155
- NEG instruction, 176, 179, 327, 350
- NES macro, 530, 541, 543, 546
- nested, task flag (NT), 617
- nested DUP clauses, 110
- nested macro call, as argument, 527
- nested procedure, 119
- nested segment, 56
- nested task flag (NT), 298
- new instructions, 659
- NEX macro, 524
- NMI, interrupt, 624
- non-combinable segment, 44, 51, 53
- non-maskable interrupt (NMI), 619, 624
- non-printable characters, ASCII, 655

- non-relocatable address, 63
- non-symbolic reference, 44, 63, 64, 575
- NOP instruction, 35, 115, 176, 181, 351
- normal scanning mode, textmacros, 522, 552
- NOSEGFIX directive, 561, 575
- NOT instruction, 32, 176, 327, 352, 651
- NOT notation, 202
- NOT operator, 123, 134, 528, 651
- NOTD operator, 142
- NOTHING, 59, 63

## O

- object file, omit symbol information, 125
- octal data, specification rules, 82
- offset
  - address, 51, 317
  - attribute, label, 112
  - attribute, variable, 86
  - effective address calculation, 165
  - relocatable address, data segment, 132
  - segment, 598
- OFFSET operator, 135, 146, 148
- opcode format, instructions, 185
- operand
  - \$, 113
  - [regname], 165
  - codemacros, 560
  - direct memory addressing, 164
  - implicit, 128
  - indirect addressing, 164
  - instructions, 39, 161, 182
  - segment name, 52
- operand size
  - attribute, 184, 308
  - prefix, 186
  - USE attribute, 52
- operands, floating-point instructions, 450
- OperandSize pseudocode notation, 202
- operation locator formats, floating-point
  - coprocessor, 439
- operators, 134
  - precedence rules, 136
- operators, textmacros, 528
- OR instruction, 32, 176, 179, 327, 615, 651
- OR operator, 134, 142, 528, 651
- ordinal, 80, 89, 90, 92

- ORG directive, 30, 111, 114
- OUT instruction, 31, 173, 181, 355, 611
- OUT macro, 525, 530, 550
- output stream, macro processor, 557
- OUTS instruction, 33, 173, 181, 357, 377, 611
- OUTSB instruction, 357
- OUTSD instruction, 357
- OUTSW instruction, 357
- overflow flag (OF), 348, 353, 375, 389, 437, 614, 616
- overflow, interrupt, 625
- override byte, 61

## P

- packed BCD format, 590
- paged memory, 599, 660
- parameters, stack frame, 272
- parity flag, 178
- parity flag (PF), 310, 386, 614, 615
- partial record, 100
- PG control flag, 595
- pm= notation, 201
- pointer, 93
  - format, 590
  - operand, 250
  - relocatable address, data segment, 132
  - variable, type, 78
- POP instruction, 32, 48, 161, 178, 186, 360
- Pop pseudocode function, 203
- POPA instruction, 32, 178, 363
- POPAD instruction, 32, 178, 363
- POPF instruction, 32, 178, 365, 618
- POPFD instruction, 32, 178, 365
- precedence, ASM386 operators, 136
- precedence, exceptions and interrupts, 621
- precedence, operators in textmacros, 528
- precision exception, floating-point coprocessor, 438
- prefix codes, instructions, 186
- prefix, instruction, 186
- PREFIX66 directive, 561, 562, 572, 662
- PREFIX67 directive, 561, 562, 572, 662
- present field, descriptor, 602
- privilege level, 605
- PROC directive, 30, 111, 119
- procedure, 119
  - nested, 119
- processor
  - data formats, 588
  - exceptions, 207, 618
  - interrupts, 618
  - stack, 593
- PROCLen function, 119, 140, 562, 563, 581
- program
  - entry point, 69
  - general structure, 40
  - segment, 49
  - with modules, 67
- program example, 633
- projective infinity, 445, 478
- protected mode, 50
- protected mode exceptions, 207
- protection checking, privilege levels, 605
- protection, descriptors, 604
- PTR operator, 44, 72, 130, 135, 155
- PTR, codemacros, 573
- ptr16:16, ptr16:32 notation, 198
- PUBLIC attribute, 51, 53
- PUBLIC directive, 29, 71, 74, 128
- PUBLIC, procedures, 119
- PURGE directive, 30, 125, 651
- PUSH instruction, 32, 48, 161, 178, 186, 361, 367
- Push pseudocode function, 203
- PUSHA instruction, 32, 178, 363, 369
- PUSHAD instruction, 32, 178, 363, 369
- PUSHF instruction, 32, 178, 371
- PUSHFD instruction, 32, 178, 371
- PWORD type, 72, 79, 94, 150, 155, 661

## Q

- qbase field, SIB byte, 563
- quote character, in strings, 89
- QWORD type, 72, 79, 96, 150, 155

## R

- r/m field, ModRM byte, 188, 563
- r/m16, r/m32 notation, 195
- r/m8 notation, 195
- r8, r16, r32 notation, 195

- range specifiers, codemacros, 571, 586
- ranges, numeric values, 81
- RCL instruction, 32, 177, 179, 372, 615
- RCR instruction, 32, 177, 179, 372, 615
- real address mode, 50
  - exceptions, 207
- reals, floating-point coprocessor, 442
- record
  - allocation statement, 97, 100
  - field, 99, 100
  - field as operator, 135, 160
  - initialization directive,
    - codemacros, 561, 579
  - type, 72, 150
  - variable, 78, 84, 98, 100, 107
- RECORD directive, 30, 84, 99
- reference, anonymous, 130
- reg field, ModRM byte, 188
- reg/opcode field, ModRM byte, 563
- register addressing, assumptions, 168
- register expression, 129, 130, 165
- register indirect, addressing, 166
- rel8, rel16, rel32 notation, 198
- RELB directive, 561, 582
- RELD directive, 561, 582
- relocatable address, 129
  - code segment, 65
  - data segment, 65
- relocatable expressions, 132
- relocatable segment, 60
- relocatable symbol
  - code segment, 63, 64
  - data segment, 64, 132
- RELW directive, 561, 582
- reopen segment, 54
- reopened segment
  - access, 52
  - restriction, 54
- REP instruction, 376
- REP instruction prefix, 35, 186, 284, 330, 344, 358, 567
- REPE instruction, 376, 394
- REPE instruction prefix, 186, 261
- REPEAT macro, 524, 530, 544
- REPNE instruction, 376, 394
- REPNE instruction prefix, 186, 261
- REPNZ instruction, 376
- REPZ instruction prefix, 186
- REPZ instruction, 376
- REPZ instruction prefix, 186
- reserved words, 125, 651
- RESET floating-point coprocessor, 477
- RESET, coprocessor, 500
- restrictions
  - \* in textmacro calls, 534, 536, 537
  - ASSUME CS, 60
  - ASSUME data segment register, 62
  - ASSUME SS, 61
  - codemacro definition, 54
  - COMM variables, 74
  - data/stack combined (dsc) segment
    - attributes, 58
  - DEFINE in macro body, 530
  - FAR labels, 116
  - index register, 167
  - initialize segment registers, 45
  - LOCAL textmacro identifier, 531
  - macro call delimiters, 553
  - macro symbol access, 522
  - numbers in textmacros, 528
  - procedure definition, 54
  - PURGE, 125
  - record field initialization,
    - codemacros, 579
  - reopened segment, 54
  - segment override, 153, 165, 424
  - structure definition, 54
  - structure field defaults, 106
  - textmacro Identifiers, 527
  - unique identifier, 26
- resume flag (RF), 618
- RET instruction, 34, 117, 119, 180, 319, 381
- RO access, 52
- ROL instruction, 32, 177, 179, 372, 615
- ROR instruction, 32, 177, 179, 372, 615
- rounding, floating-point coprocessor, 444
- RPL, 295
- RPL field adjustment, 224
- RPL field, selector, 603
- RW access, 52

## S

- SAHF instruction, 32, 174, 386
- SAL instruction, 32, 177, 179, 387
- SAR instruction, 32, 177, 179, 387
- SBB instruction, 176, 179, 327, 391
- scale factor
  - addressing, 168
  - based indexed addressing, 167
  - indexed addressing, 129
- scale factor field, SIB byte, 189
- scaled addressing, 129, 165
- scaled indexed addressing, 189
- scanning modes, macro processor, 552
- SCAS instruction, 33, 176, 179, 393, 576
- SCASB instruction, 393
- SCASD instruction, 393
- SCASW instruction, 393
- SEG operator, 46, 59, 75, 135, 145
- SEGFIX, 561
- SEGFIX directive, 562, 574
- segment
  - accessing, 58
  - address, 597
  - attribute, label, 112
  - attribute, variable, 86
  - close and reopen, 54
  - defining, 51
  - descriptor, 601, 602
  - modular programs, 53
  - name, operand, 161
  - nested, 56
  - non-combinable, 51, 53
  - relocatable, 60, 132
- SEGMENT directive, 29, 42, 51
- segment override
  - operators, 44, 60, 63, 134, 135, 153, 169, 409
  - prefix byte, 61, 574
  - prefix generation, 61
  - prefixes, 186
- segment register, 593
  - cache, 601
  - initialization, 45, 69
- segmented address space, 597
- selector
  - ASSUME, 60
  - segment, 59
- selector format, 603
- selector, SEG, 145
- selector, segment, 45, 593
- separator, 24
- SET cc instruction, 395
- SET macro, 524, 530, 540
- SETcc instruction, 32, 176, 180, 259, 415
- SF field, SIB byte, 563
- SGDT instruction, 34, 174, 181, 321, 397
- SGDTW/SGDTD instructions, 34, 174, 181, 399
- shift
  - count, 389
  - count, record field, 135, 160, 580
- SHL instruction, 32, 177, 179, 387, 651
- SHL operator, 123, 134, 139, 528, 651
- SHLD, 400
- SHLD instruction, 32, 177, 179
- short integer, floating-point coprocessor, 440
- SHORT operator, 135, 157
- short real, coprocessor, 440
- SHR instruction, 32, 177, 179, 387, 651
- SHR operator, 123, 134, 139, 528, 651
- SHRD instruction, 32, 177, 179, 402
- SI register, 46, 129, 161, 165, 168, 260, 329, 343, 357, 363, 369, 407
- SIB byte, 186, 188, 563, 577
- SIDT instruction, 34, 174, 181, 182, 321, 397
- SIDTW/SIDTD instructions, 34, 174, 181, 182, 399
- sign flag, 178
- sign flag (SF), 310, 386, 614, 615
- SignExten pseudocode function, 202
- single precision real, floating-point coprocessor, 440
- SIZE operator, 85, 135, 151
- size segment, maximum, 49
- SLDT instruction, 34, 174, 181, 404
- SMSW instruction, 34, 174, 182, 405
- software interrupts, 618
- source operand, 183
- SP register, 42, 45, 152, 161, 177, 185, 273, 319, 361, 368, 369, 371
- spaces, logical, 25

- special characters, 24, 27
- specifications, data, 82
- specifiers, codemacros, 568, 585
- Sreg notation, 199
- SS register, 47, 50, 59, 67, 69, 153, 161, 165, 169, 314, 340, 360, 367, 575, 593
  - (E)SP, initializing, 47, 69
- SS:(E)SP, initialize, 58
- ST(i) notation, 455
- stack, 152, 593
  - fields, floating-point coprocessor, 430
  - frame, 593
  - frame base pointer register, 48
  - pointer register, 48
  - segment, 49
  - size attribute, 185
- stack pointer, 273, 319
  - initialization, 152
- STACKSEG directive, 29, 42, 57, 152
- STACKSTART operator, 47, 58, 135, 152
- statement, 29
  - general syntax, 38
- status flags format, 613
- status flags, assignments, 178
- status word, floating-point coprocessor, 433, 477, 506, 507
- STC instruction, 32, 175, 406
- STD instruction, 32, 175, 329, 394, 407, 410
- STI instruction, 32, 175, 182, 408
- storage allocation statement, 84
- storage format, 83
- STOS instruction, 33, 174, 378, 409, 576
- STOSB instruction, 409
- STOSD instruction, 409
- STOSW instruction, 409
- STR instruction, 34, 174, 182, 411
- string
  - access, 80
  - format, 590
  - operations, override restrictions, 153, 165, 169
- STRUC directive, 30, 85, 99, 104
- structure
  - allocation statement, 99, 106
  - BIT-type fields, 87, 104
  - type, 72
  - variable, 79, 84, 98, 104, 107

- structure field, 104
  - BITOFFSET, 147
  - displacement, 131
  - type, 131
- SUB instruction, 176, 179, 216, 327, 412
- SUBSTR macro, 525, 530, 548
- subtraction operator, 140
- SwitchTasks pseudocode function, 204
- symbolic reference, 44, 63
- symbolic reference, codemacro call, 575
- symbolic value, in macro symbol table, 540, 549
- symbols, 122
  - PUBLIC, 71
  - PURGE restrictions, 125
  - relocatable, 132
- syntax, instruction statements, 182
- system control flags, 616
- system registers, 594

## T

- tag word, floating-point coprocessor, 438, 478, 506
- task, switches, 604
- task gate, 606
  - descriptor, 607
- task switched flag (TS), 256
- TBYTE type, 72, 79, 98, 150, 155
- tempreal, coprocessor, 440
- TEST instruction, 32, 176, 179, 414
- THIS operator, 135, 144
- TI field, selector, 603
- token, 24
- TOP, floating-point coprocessor, 435
- TR register, 411, 608
- TR3 register, 161
- TR4 register, 161
- TR5 register, 161
- TR6 register, 161, 341, 659
- TR7 register, 161, 341, 659
- trap flag (TF), 617
- trap gate, 606
- trap, exception, 618
- Truncate pseudocode function, 202
- TS control flag, 595
- TSS descriptor, 336, 607

- TSS fields, 610
- TSS layout, 608
- type attribute
  - label, 112
  - variable, 84
- type field, descriptor, 604
- TYPE operator, 135, 149, 150
- types, variables and labels, 78

## U

- underflow exception, floating-point coprocessor, 437
- USE attribute, 184, 308
  - label, 112
  - segment, 49, 51, 52
  - stack segment, 45, 57, 185
  - variable, 86
- USE16, 49, 51, 52, 72, 146, 361, 368, 483, 495, 506
- USE16 instruction, 431
- USE32, 49, 51, 52, 72, 146, 361, 368, 483, 495, 506
- USE32 instruction, 431

## V

- value
  - external constant, 133
  - register expression, 130
- value, ASSUME CS
  - NOTHING, 63
- values, hexadecimal to ASCII, 655
- values, privilege level, 605
- variable
  - addressing offset, 128, 129
  - attributes, 86
  - byte string, 89
  - compound type, 78, 99
  - EXTRN placement in code, 73
  - global, 74

- initialization, 83
- labeled, 116
- relocatable in data segment, 132
- shared across modules, 71
- uninitialized storage, 74, 89, 90, 91, 92, 94, 97, 110

- VERR instruction, 34, 176, 179, 181, 416
- VERW instruction, 34, 176, 179, 181, 416
- Virtual 8086 mode exceptions, 208
- virtual mode flag (VM), 617

## W

- WAIT instruction, 34, 181, 182, 418
- WARNING directive, 561, 576
- WBINVD instruction, 182, 419
- WHILE macro, 524, 527, 530, 543
- WIDTH operator, 85, 135, 158
- WORD type, 72, 79, 90, 150, 155

## X

- XADD instruction, 176, 179, 420
- XCHG instruction, 31, 175, 327, 351, 422
- XLAT instruction, 31, 424
- XLATB instruction, 31, 424
- XOR instruction, 32, 176, 179, 327, 426, 615, 651
- XOR operator, 123, 134, 142, 528, 651

## Z

- zero flag, 178
- zero flag (ZF), 310, 331, 334, 379, 386, 416, 614, 615
- zerodivide exception, floating-point coprocessor, 437
- ZeroExtend pseudocode function, 202